

LKZ 80152

Modellname/Modelname/Nomdu modele/Modellnamn
 Nome modello/Název modelu/Modelnaam/Imodela
 Número Modelo/Modelneve/ Название модели /
 Názov modelu/Imodela/Denumire model/
 Наименование модели /Nazwa modelu

TTX07

Modellnummer/Number/Numéro du modèle
 Numero/ Номерна модель /modello
 Číslo modelu/Modellszám/Előszám
 Številka modela/ Număr model /Broj modela
 Modelnummer/Nummermodelu

1563-001-01 

Type/Тіро/Тіpus/Тур/Тип /Тір

001

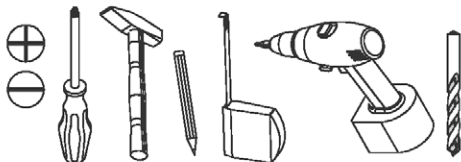
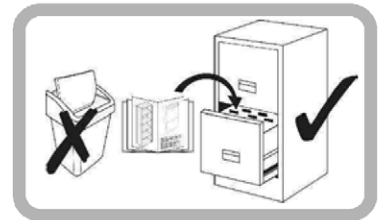
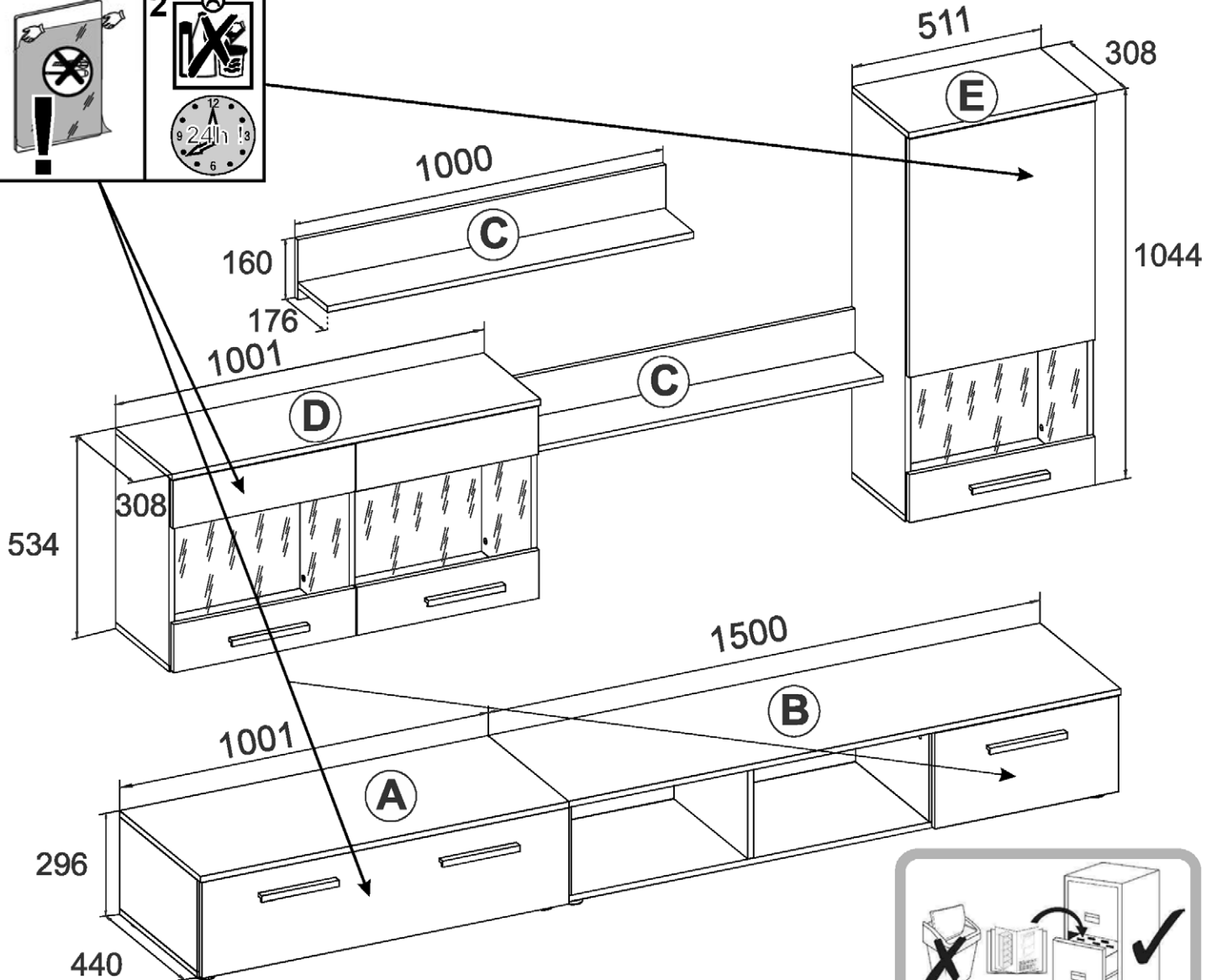
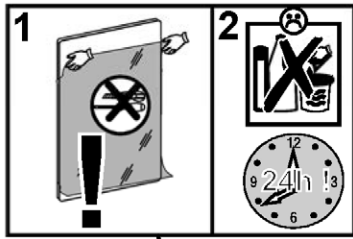
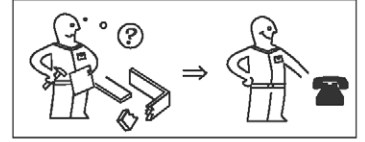
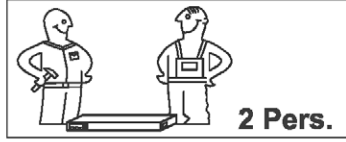

festziehen / tighten / Затягивать /
 serrer / stringere / utåhnout / vástrekken /
 zategnuti / strångere / związac / zacisnąć
 szorosan meghúzni / pevne dotiahnuť /
 trdno pritegniti / затянуть / dra līt



eindrücken / press in / enfoncer / wcisnąć
 ribattere / zatlačit / Вкарайте / indrukken
 in / вкати / вкати / вкати / вкати /
 introducere prin apăşare / вдавить



ausmessen / measure / mesurer /
 misurare / opmeten / izmeriti / miara /
 kimérni / izmeriti / măsurare / измерить
 změřit / Измерете / mät upp / zmierzyc



drücken / press / presser / stisknout /
 Натиснете / vtiisniti / nasinac / drukken /
 pritisniti / nacisnac / pritisniti / нажать /
 (meg)nyomni / apăşare / trucky fast / nacisnąć



einschlagen / hammer in / bevemi / slå in
 frapper au marteau / infossare / Zabit' /
 zarazit / Набийте / zabiti / wbić
 introducere prin bătaie / забить / zatloct



Drehen - wenden / przekreć - odwrócić /
 Keren - omdraalen / Girare - Ruotare /
 Okrenuti - ubnuti / Retourner - renverser /
 Turn over - tum around / Otočte - obratite /
 Intoarceşte - rotii / Vrid runt - vänd /
 прокрутити повернуть / otočit - obrátiť
 elforgått - megfordítani

LKZ 80152

Modellname/Modelname/Nomdumodele/Modellnamn
Nomemodello/Názvemodelu/Modelnaam/Imemodella
NuméroModello/Modellineve/ Названиemodeli /
Názovmodelu/Imemodella/Denumiremodel/
Наименованиemodela /Nazwamodelu

TTX07

Modellnummer/Number/Numérodumodele
Numero/ Номернамодела/modello
Číslomodelu/Modellszáma/Elslomodelu
Številkamodela/ Numämodel /Brojmodela
Modelnummer/Numemodellu

1563-001-01

Type/Тipo/Тípus/Тур/Тип /Tip

001

D Unser Direktservice für Beschlagteile
Sollte Ihnen ein Beschlagteil fehlen, können Sie diese Servicekarte
direkt an die untenstehende Adresse mailen. Wir können allerdings
nur Beschlagteile auf diesem Wege verschicken. Sollten Sie eine
andere Beanstandung an Ihrem Möbelstück haben, so wenden sie
sich bitte direkt an Ihr Möbelhaus.

GB Our direct order service for fitting
If a fitting part is missing, you can e-mail this service card directly
to the address below. However, we can only send fitting parts in
this way. If you have any other cause for complaint concerning
your item of furniture, please contact your furniture store directly.

CZ Naše přímé služby pro kování
Chybí-li vám nějaký díl z kování, můžete tuto servisní kartu odeslat
e-mailem přímo na níže uvedenou adresu. Touto cestou však
můžeme rozesílat jen díly kování. Pokud byste reklamovali jiný díl
nábýtku, obraťte se přímo na svého prodejce nábýtku.

F Bien étudier la notice de montage
S'il vous manque une ferrure, veuillez envoyer directement la présente
carte service à l'adresse e-mail indiquée ci-dessous. Cependant, ceci
nous permet uniquement d'envoyer des ferrures. Pour tout autre type
de réclamation concernant votre meuble, veuillez contacter
directement votre magasin d'ameublement.

I Il nostro servizio diretto per l'ordine della ferramenta
Qualora Vi dovesse mancare un pezzo di fissaggio, allora Vi
preghiamo di inviare questa carta di servizio immediatamente
all'indirizzo sottostante. Possiamo inviare i pezzi di fissaggio
solamente per mezzo di questo procedimento. Qualora dovete
avere qualche altra reclamazione in merito al mobile, allora Vi
preghiamo di rivolgerVi direttamente al Vostro Negozio di mobili.

BG Нашата директна услуга за обкова
Ако липсват части от комплекта, потънете настоящата
сервисна карта и ни я изпратете на e-mail адреса, посочен
по-долу. По този начин можем да доставяме само липсващи
елементи от обкова. Ако установите други дефекти по
мебелите, Ви съветваме да се обрънете към мебелната
къща/магазин, от който сте закупили стоката.

NL Onze directservice voor losse onderdelen
Wanneer er een onderdeel ontbreekt, kunt u deze servicekaart
direct aan onderstaand e-mailadres sturen. Wij kunnen langs deze
weg echter alleen beslagdelen versturen. Mocht u een ander
probleem aan uw meubel hebben, verzoeken wij u contact op te
nemen met uw meubeldealer.

PL Nasz bezpośredni serwis części montażowych
Jeżeli brakuje części koniecznych do montażu, prosimy o przesłanie
nam niniejszej karty serwisowej na niżej podany adres e-mailowy.
W ten sposób możemy przelać Państwu tylko brakujące części.
W przypadku innych reklamacji dotyczących mebla, prosimy zgłosić
się do salonu meblowego, w którym został dokonany zakup.

HR Servis za okove
U slučaju da nedostaje neki od dijelova molimo vas da na dole
navedenu mail adresu pošaljete ovaj servisni obrazac. Na ovaj način
mogu se dostaviti samo okovi. U slučaju da imate dodatne prigovore
vezane uz komad namještaja molimo vas da se obratite izravno
trgovini namještaja gdje je isti kupljen.

HU Direktszolgáltatunk vasalatok esetén
Ha hiányzik egy vasalat, ezt a kártyát közvetlenül elküldheti az
alább található címre. Azonban csak vasalatoskat tudunk így
küldeni. Amennyiben másfajta reklamáció áll fenn bútordarabját
illetően, forduljon közvetlenül a bútorházhöz.

SK Náš priamy servis pre časti kovania
Ak by Vám chýbala nejaká časť kovania, môžete poslať
túto servisnú kartu poslať e-mailom na nižšie uvedenú
adresu. Diely kovania vieme poslať iba týmto spôsobom.
Ak by ste mali inú reklamáciu ohľadom Vášho nábýtku,
obráťte sa priamo na Vašu predajňu nábýtku.

SLO Naše direktno uslužne storitve za okovje
Če vam manjka kakšno okovje, lahko to servisno kartico pošljete
po e-pošti direktno na spodnji naslov. Po tej poti vam lahko
pošljemo samo okovje. Če želite reklamirati kakšno drug del
pohištva, se obrnite neposredno na vašo trgovino pohištva.

RO Service-ul nostru direct pentru feronerie
În cazul în care vă lipsește o piesă de feronerie puteți să trimiteți
direct acest card de service prin e-mail la adresa de mai jos. Noi
nu putem expedia piese de feronerie decât pe această cale.
Dacă aveți o altă reclamație referitoare la piesa de mobilier,
atunci vă rugăm să vă adresați direct la magazinul dvs. de mobilă.

RUS Наш прямой сервис для поставок фурнитуры
Если окажется, что Вам не хватает того или иного элемента
фурнитуры, Вы можете отправлять сервисную карту по факсу
непосредственно на нижеприведенный адрес электронной
почты. Однако, таким образом мы можем пересылать лишь
фурнитуру. Если же у Вас возникнут иные претензии относительно
приобретенной мебели, пожалуйста, обращайтесь
непосредственно в организацию, осуществившую продажу.

S Vår direktservice för beslagdelar
Om du saknar en beslagdel kan du skicka detta servicekort direkt
till e-postadressen som anges nedan. Tänk på att detta är den enda
möjligheten att skicka beslagdelar till dig. Om du vill reklamera din
möbel av en annan anledning måste du kontakta ditt möbelhus direkt.

ES Nuestro servicio directo para accesorios
Si le falta algún accesorio, puede enviar esta tarjeta de servicio directamente a
la siguiente dirección. No obstante, por este método solo podemos
enviar accesorios. Si tiene alguna otra objeción sobre su mueble, consulte
directamente con su mueblería.

TR Donatılar için doğrudan servisimiz
Bir donatınız eksikse bu servis kartını doğrudan aşağıda bulunan adrese
doğrudan mail yazabilirsiniz. Sadece bu yolla donatılar gönderiliriz.
Mobilyanızda başka şikayetleriniz varsa lütfen doğrudan mobilya satıcınıza
danışın.

max.

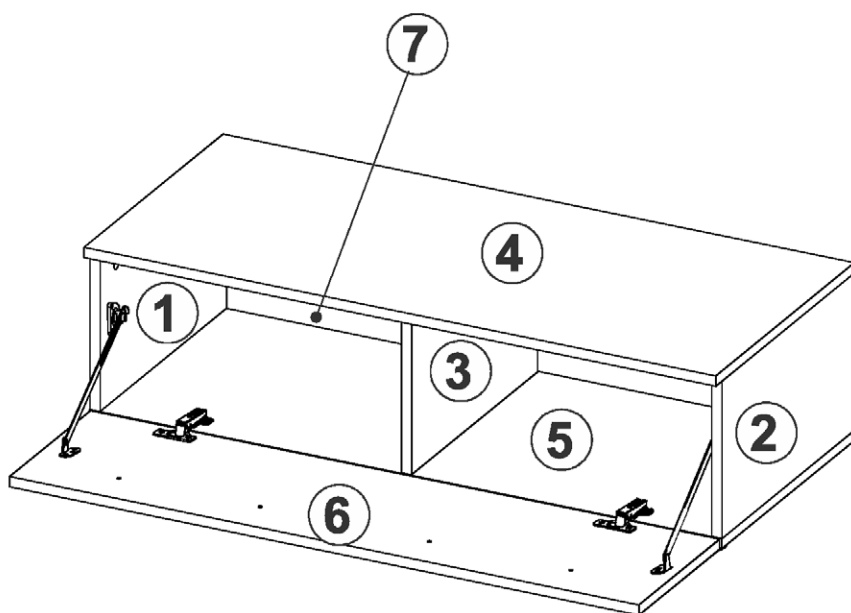

Colli 2

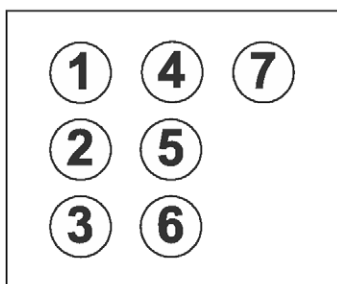

4	7014368
6	7014371
1	7014369
2	7014370
3	7014373
7	7014374
5	7014367

GrunderBeanstandung/Reasonoftheobjection:

Möbelhaus/Furniturestore:

Name/Nom: Telefon/Telephone:

PLZ/Banksortingcode: Ort/City:

Strasse/Street:

Haus-Nr./HouseNo.: @E-Mail:

LKZ 80152

Modellname/Modelname/Nomdumodele/Modellnamn
Nomemodello/Názevmodelu/Modelnaam/Imemodela
NúmeroModello/Modellneve/ Названиемодели /
Názovmodelu/Imemodela/Denumiremodel/
Наименованиемодела /Nazwaodelu

TTX07

Modellnummer/Number/Numérodumodele
Numero/ Номернамодела/modello
Číslomodelu/Modellszáma/Elsiomodelu
Številkamodela/ Numärrmodel /Brojmodela
Modelnummer/Numemodellu

1563-001-01

Type/Tipo/Típus/Typ/Тип /Tip

001

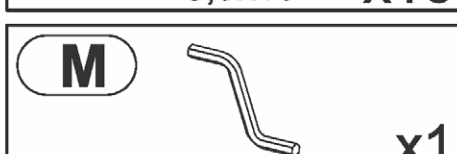
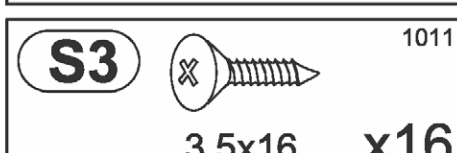
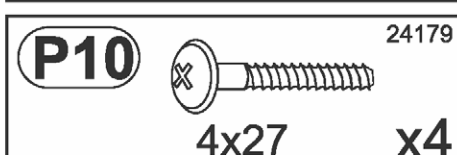
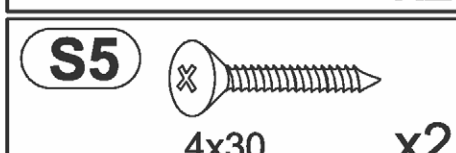
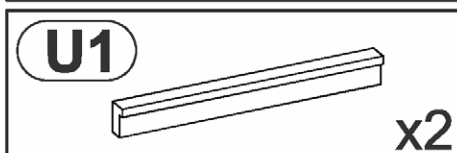
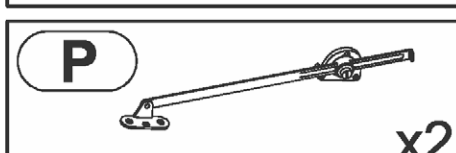
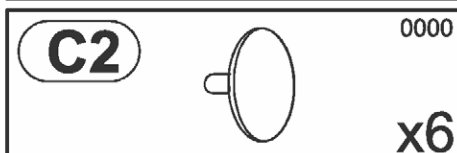
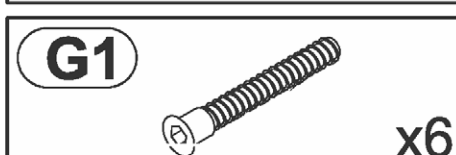
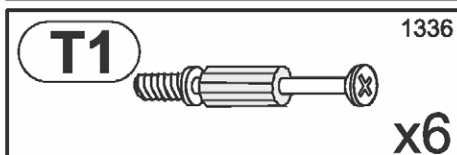
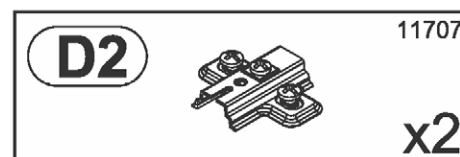
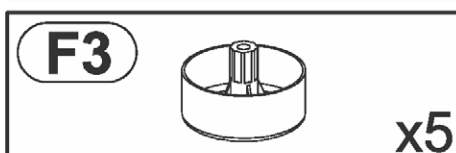
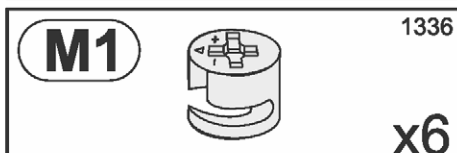
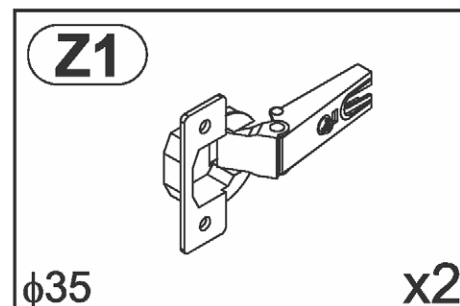
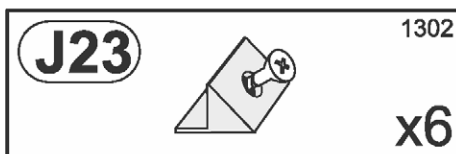
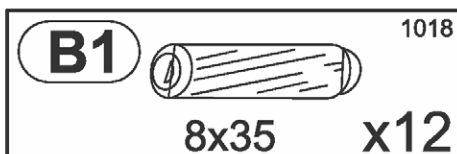

1

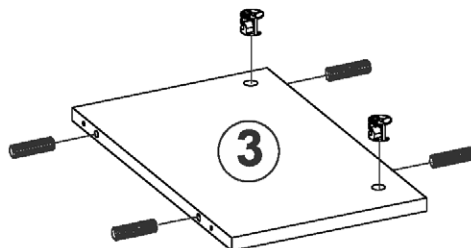
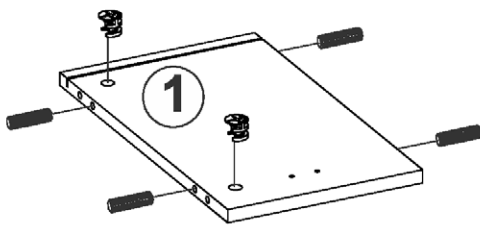
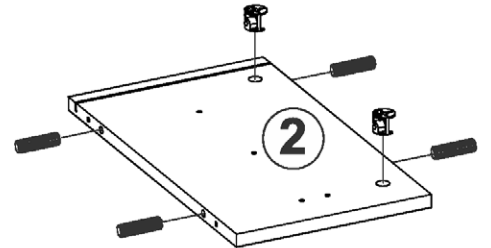
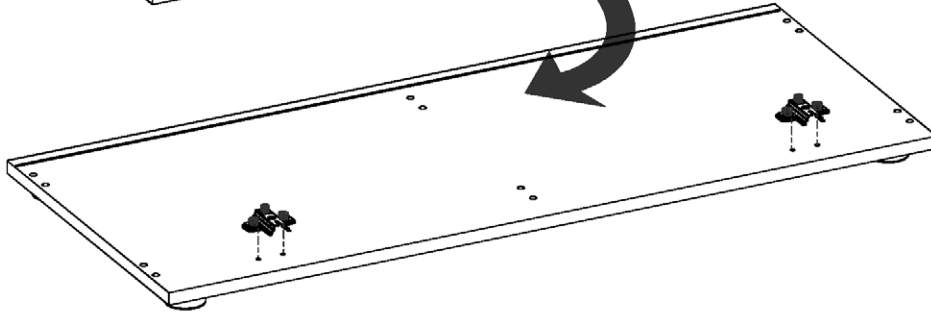
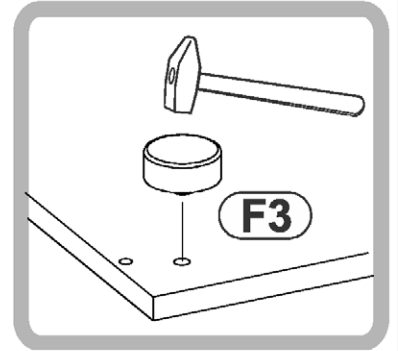
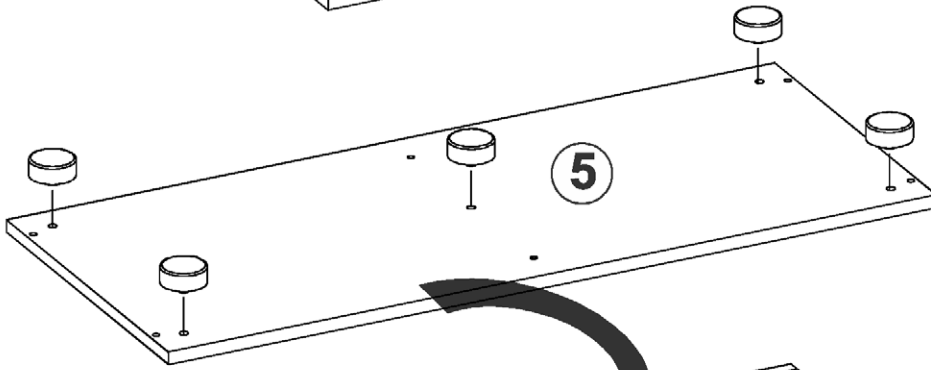
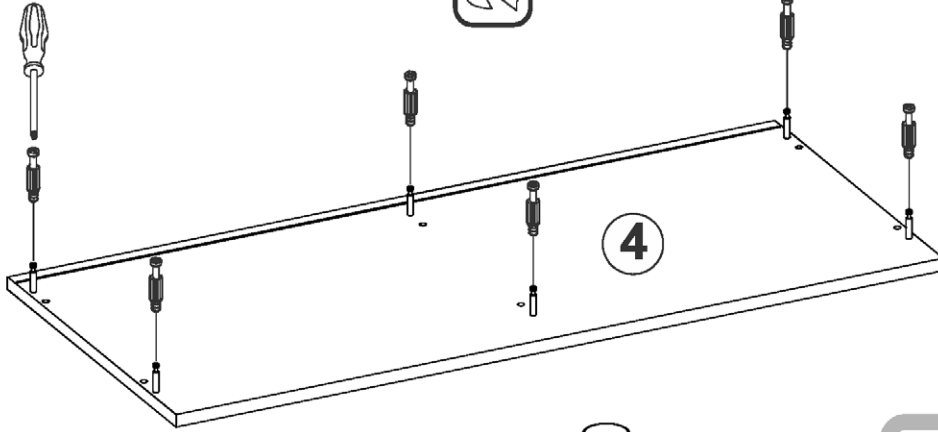
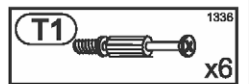
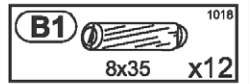
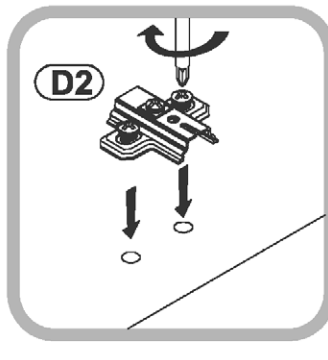
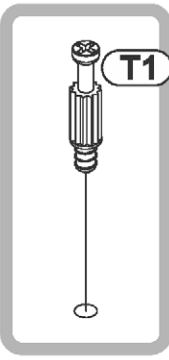
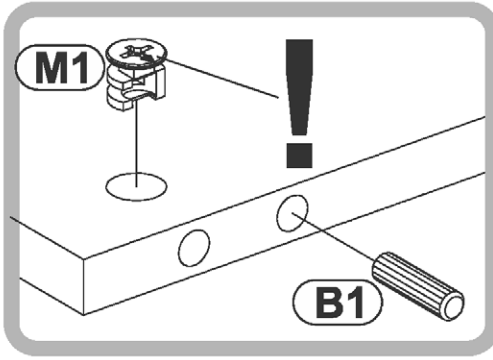

2

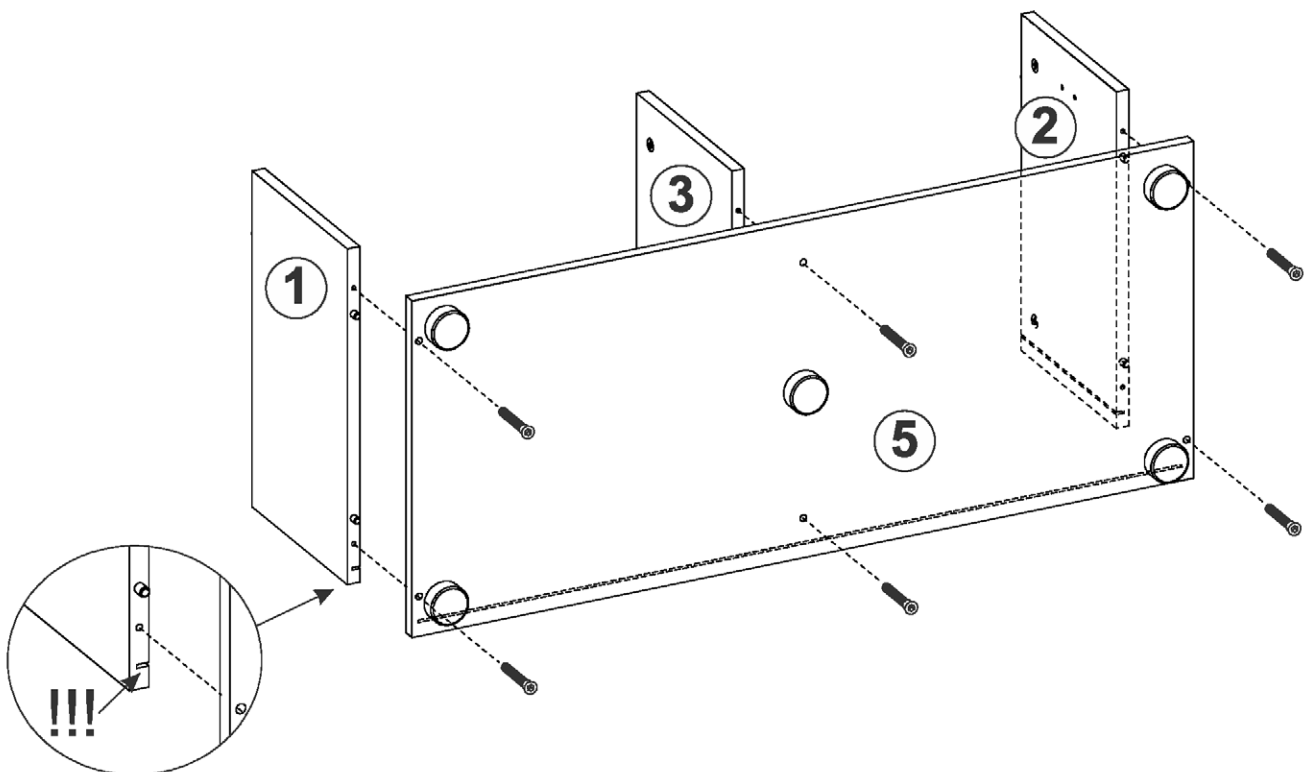
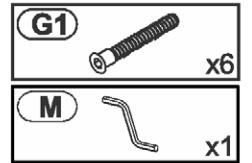
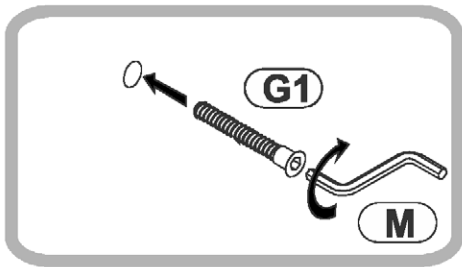
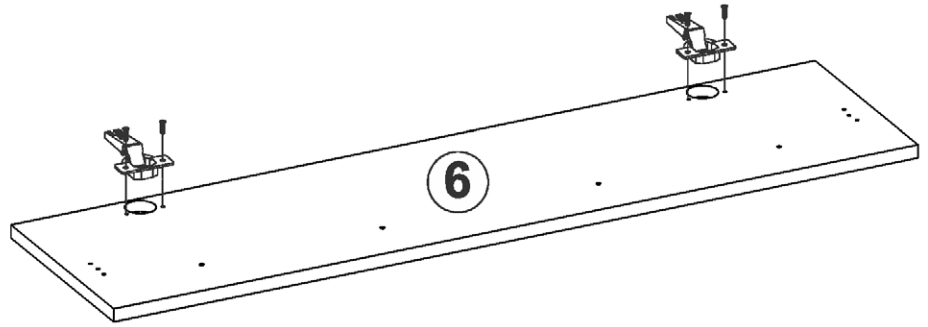
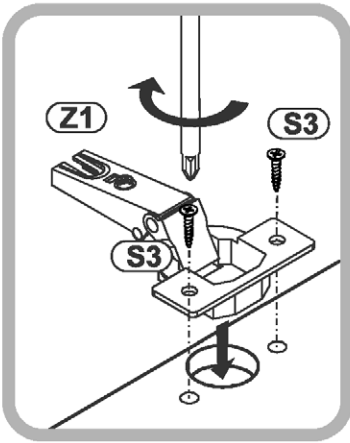
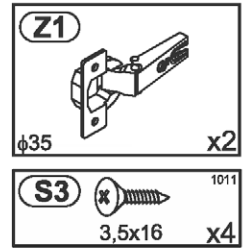
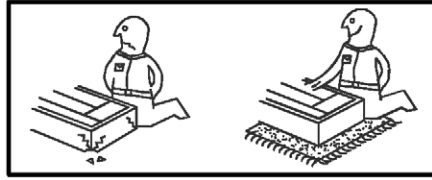

3

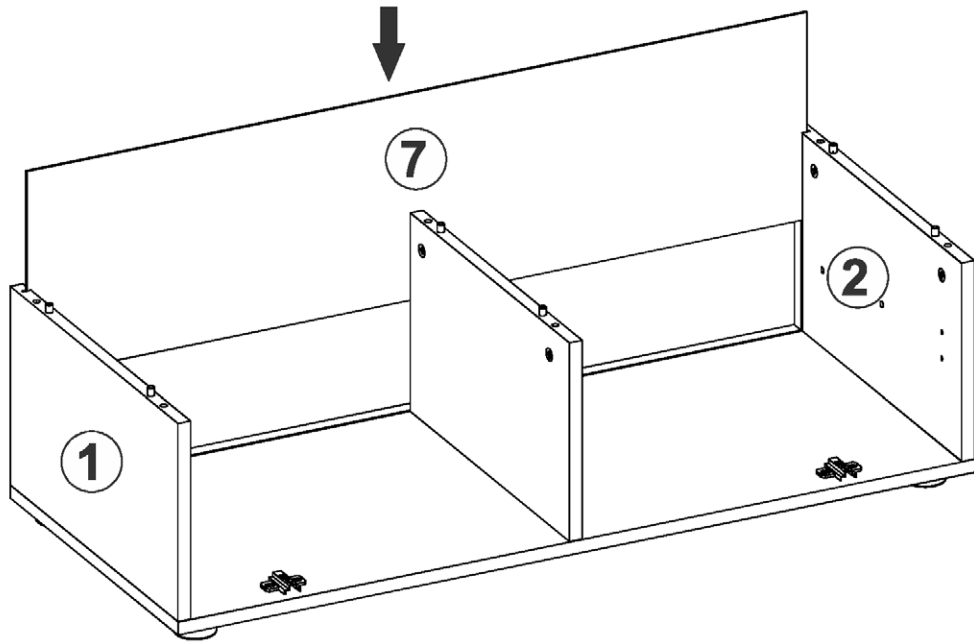

A

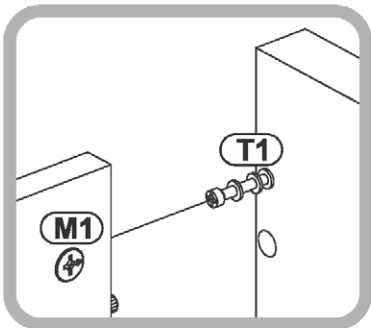

B

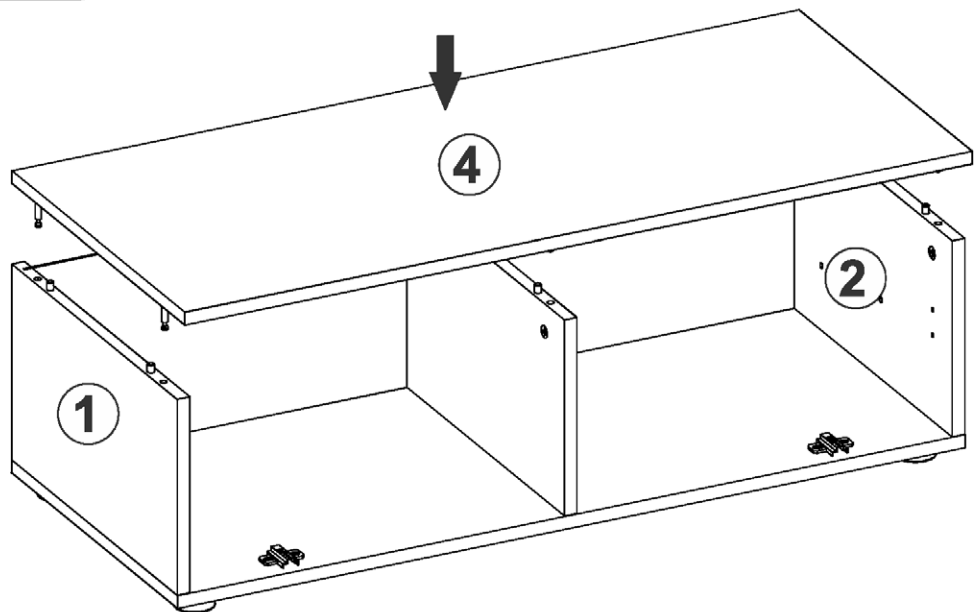
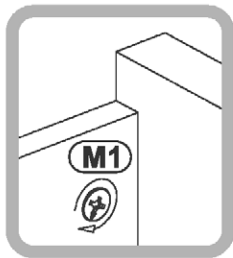

4

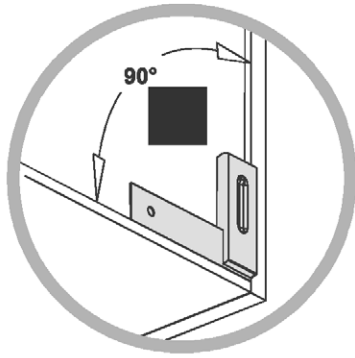

J23 1302
x6

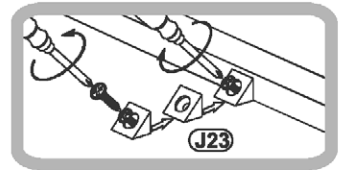
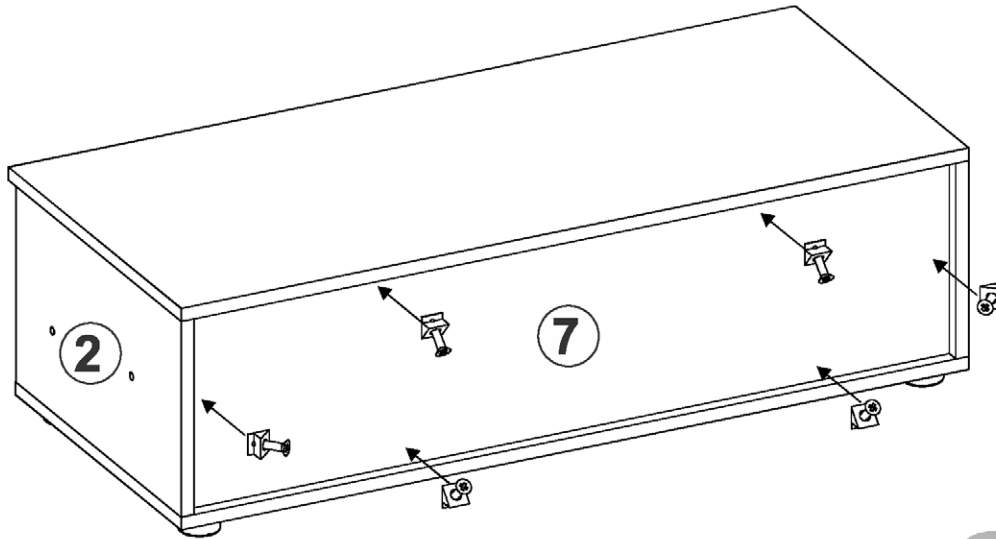

5

1.

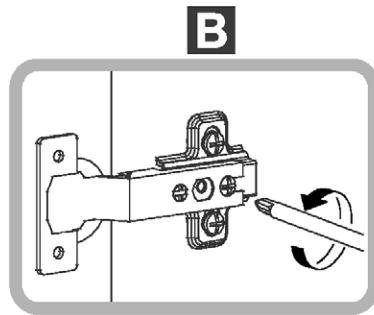
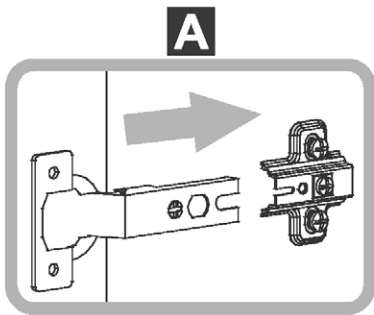

2.

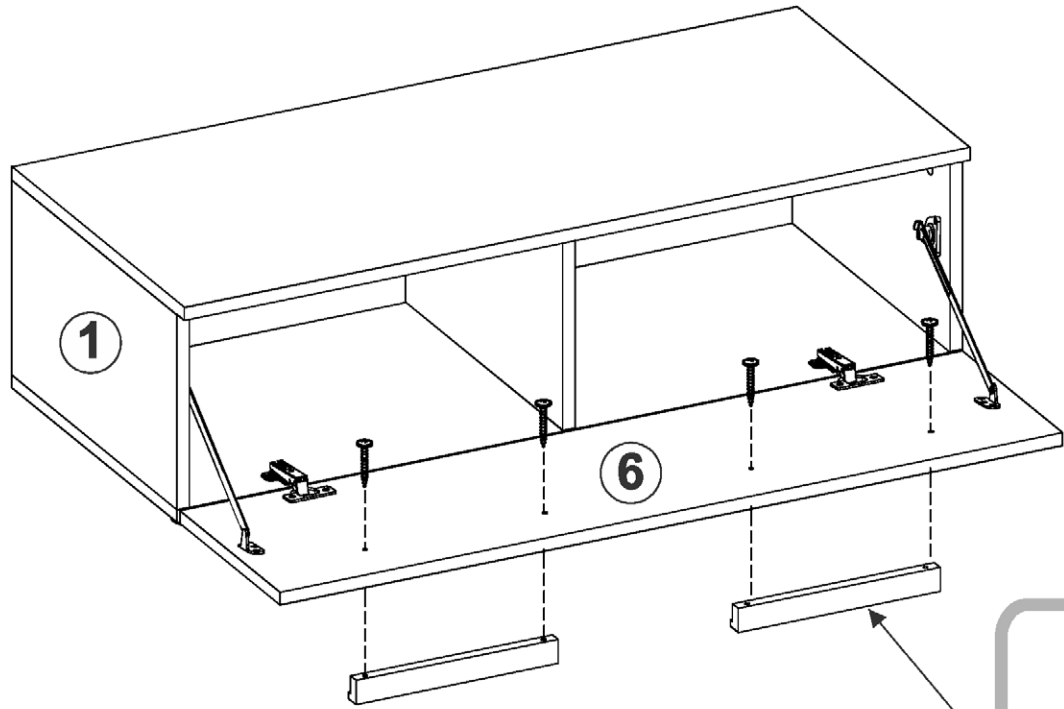
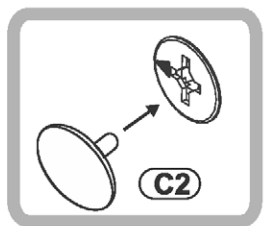
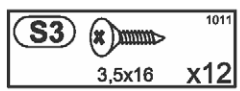
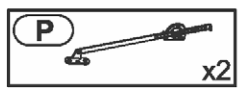
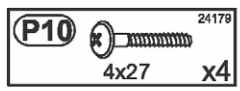
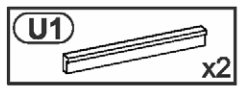
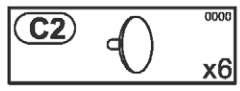
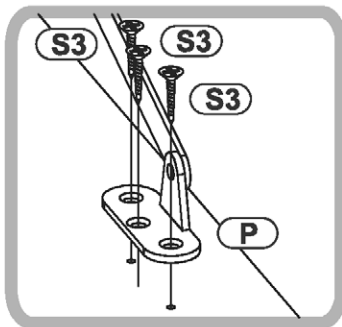
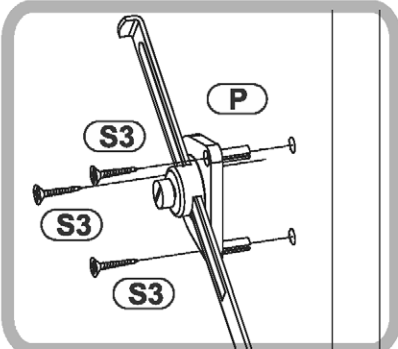

3.

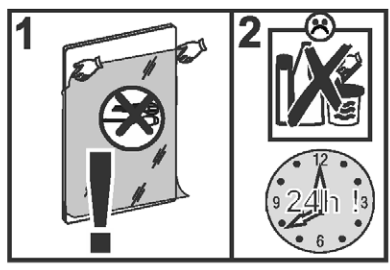

4.

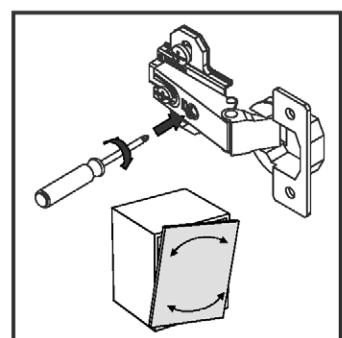
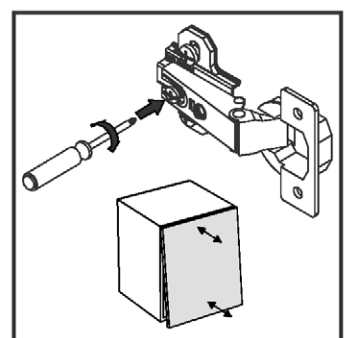
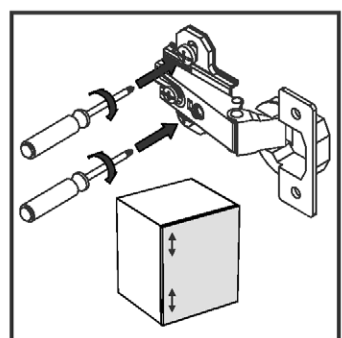
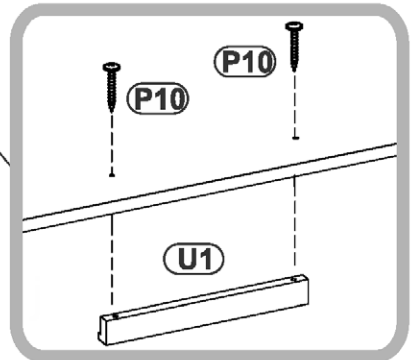

LKZ 80152

Modellname/Modelname/Nomdumodele/Modellnamn
Nomemodello/Názvmodelu/Modelnaam/Imemodela
NuméroModello/Modellineve/ Названиemodeli /
Názovmodelu/Imemodela/Denumiremodel/
Наименованиemodela /Nazwamodelu

TTX07

Modellnummer/Number/Numérodumodele
Numero/ Номернамодела/modello
Číslomodelu/Modelszám/Elslomodelu
Številkamodela/ Numämodel /Brojmodela
Modelnummer/Numemodelu

1563-001-01

Type/Тipo/Тípus/Тур/Тип /Tip

001

D Unser Direktservice für Beschlagteile
Sollte Ihnen ein Beschlagteil fehlen, können Sie diese Servicekarte
direkt an die untenstehende Adresse mailen. Wir können allerdings
nur Beschlagteile auf diesem Wege verschicken. Sollten Sie eine
andere Beanstandung an Ihrem Möbelstück haben, so wenden Sie
sich bitte direkt an Ihr Möbelhaus.

GB Our direct order service for fitting
If a fitting part is missing, you can e-mail this service card directly
to the address below. However, we can only send fitting parts in
this way. If you have any other cause for complaint concerning
your item of furniture, please contact your furniture store directly.

CZ Naše přímé služby pro kování
Chybí-li vám nějaký díl z kování, můžete tuto servisní kartu odeslat
e-mailem přímo na níže uvedenou adresu. Touto cestou však
můžeme rozesílat jen díly kování. Pokud byste reklamovali jiný díl
nábýtku, obraťte se přímo na svého prodejce nábýtku.

F Bien étudier la notice de montage
S'il vous manque une ferrure, veuillez envoyer directement la présente
carte service à l'adresse e-mail indiquée ci-dessous. Cependant, ceci
nous permet uniquement d'envoyer des ferrures. Pour tout autre type
de réclamation concernant votre meuble, veuillez contacter
directement votre magasin d'ameublement.

I Il nostro servizio diretto per l'ordine della ferramenta
Qualora Vi dovesse mancare un pezzo di fissaggio, allora Vi
preghiamo di inviare questa carta di servizio immediatamente
all'indirizzo sottostante. Possiamo inviare i pezzi di fissaggio
solamente per mezzo di questo procedimento. Qualora dovete
avere qualche altra reclamazione in merito al mobile, allora Vi
preghiamo di rivolgerVi direttamente al Vostro Negozio di mobili.

BG Нашата директна услуга за обкова
Ако липсват части от комплекта, потърнете настоящата
сервисна карта и ни я изпратете на e-mail адреса, посочен
по-долу. По този начин можем да доставяме само липсващи
елементи от обкова. Ако установите други дефекти по
мебелите, Ви съветваме да се обърнете към мебелната
къща/магазин, от който сте закупили стоката.

NL Onze directservice voor losse onderdelen
Wanneer er een onderdeel ontbreekt, kunt u deze servicekaart
direct aan onderstaand e-mailadres sturen. Wij kunnen langs deze
weg echter alleen beslagdelen versturen. Mocht u een ander
probleem aan uw meubel hebben, verzoeken wij u contact op te
nemen met uw meubeldealer.

PL Nasz bezpośredni serwis części montażowych
Jeżeli brakuje części koniecznych do montażu, prosimy o przesłanie
nam niniejszej karty serwisowej na niżej podany adres e-mailowy.
W ten sposób możemy przesyłać Państwu tylko brakujące części.
W przypadku innych reklamacji dotyczących mebla, prosimy zgłosić
się do salonu meblowego, w którym został dokonany zakup.

HR Servis za okove
U slučaju da nedostaje neki od dijelova molimo vas da na dolje
navedenu mail adresu pošaljete ovaj servisni obrazac. Na ovaj način
mogu se dostaviti samo okovi. U slučaju da imate dodatne prigovore
vezane uz komad namještaja molimo vas da se obratite izravno
trgovini namještaja gdje je isti kupljen.

HU Direktszolgáltatunk vasalattok esetén
Ha hiányzik egy vasalat, ezt a kártyát közvetlenül elküldheti az
alább található címre. Azonban csak vasalattokat tudunk így
küldeni. Amennyiben másfajta reklamáció áll fenn bútordarabját
illetően, forduljon közvetlenül a bútorházhoz.

SK Náš priamy servis pre časti kovania
Ak by Vám chýbala nejaká časť kovania, môžete poslať
túto servisnú kartu poslať e-mailom na nižšie uvedenú
adresu. Diely kovania vieme poslať iba týmto spôsobom.
Ak by ste mali inú reklamáciu ohľadom Vášho nábýtku,
obráťte sa priamo na Vašu predajňu nábýtku.

SLO Naše direktno uslužne storitve za okovje
Če vam manjka kakšno okovje, lahko to servisno kartico pošljete
po e-pošti direktno na spodnji naslov. Po tej poti vam lahko
pošljemo samo okovje. Če želite reklamirati kakšen drug del
pohištva, se obrnite neposredno na vašo trgovino pohištva.

RO Service-ul nostru direct pentru feronerie
În cazul în care vă lipsește o piesă de feronerie puteți să trimiteți
direct card de service prin e-mail la adresa de mai jos. Noi
nu putem expedia piese de feronerie decât pe această cale.
Dacă aveți o altă reclamație referitoare la piesa de mobilier,
atunci vă rugăm să vă adresați direct la magazinul dvs. de mobilă.

RUS Наш прямой сервис для поставок фурнитуры
Если окажется, что Вам не хватает того или иного элемента
фурнитуры, Вы можете отправить сервисную карту по факсу
непосредственно на нижеприведенный адрес электронной
почты. Однако, таким образом мы можем пересылать лишь
фурнитуру. Если же у Вас возникнут иные претензии относительно
приобретенной мебели, пожалуйста, обращайтесь
непосредственно в организацию, осуществляющую продажу.

S Vår direktservice för beslagdelar
Om du saknar en beslagdel kan du skicka detta servicekort direkt
till e-postadressen som anges nedan. Tänk på att detta är den enda
möjligheten att skicka beslagdelar till dig. Om du vill reklamera din
möbel av en annan anledning måste du kontakta ditt möbelhus direkt.

ES Nuestro servicio directo para accesorios
Si le falta algún accesorio, puede enviar esta tarjeta de servicio directamente a
la siguiente dirección. No obstante, por este método solo podemos
enviar accesorios. Si tiene alguna otra objeción sobre su mueble, consulte
directamente con su mueblería.

TR Donatılar için doğrudan servisimiz
Bir donatınız eksikse bu servis kartını doğrudan aşağıda bulunan adrese
doğrudan mail yazabilirsiniz. Sadece bu yolla donatılar gönderiliriz.
Mobilyanızda başka şikayetleriniz varsa lütfen doğrudan mobilya satıcınıza
danışın.

max.

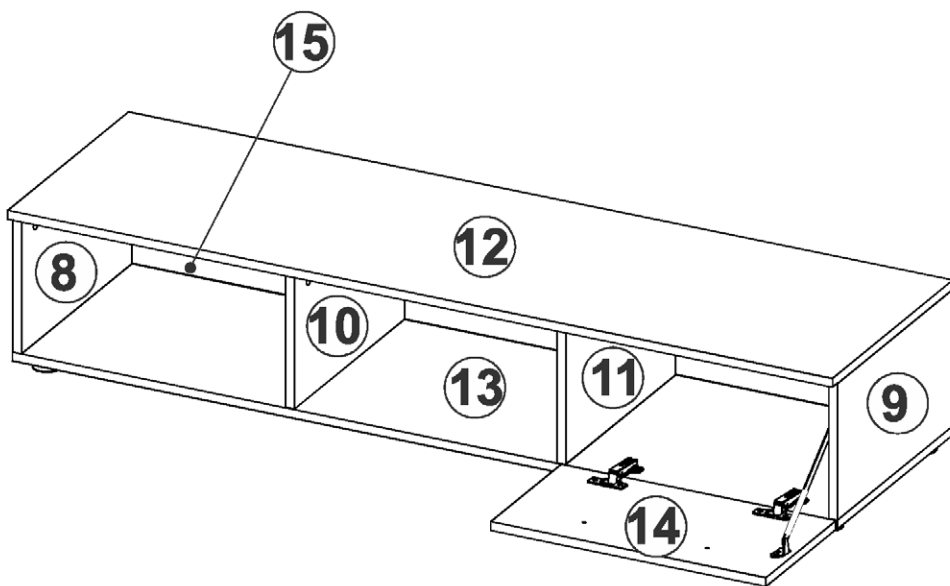

Colli 3

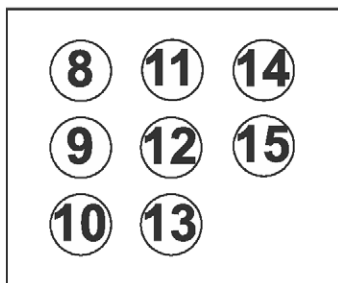

12	7014360
8	7014361
9	7014362
14	7014363
10	7014364
11	7014365
15	7014366
13	7014359

Gründer/Beanstandung/Reason of the objection:

Möbelhaus/Furniturestore:

Name/Nom:

Telefon/Telephone:

PLZ/Banksortingcode:

Ort/City:

Strasse/Street:

Haus-Nr./HouseNo.:

@E-Mail:

LKZ 80152

Modellname/Modelname/Nomdumodele/Modellnamn
Nomemodello/Názevmodelu/Modelnaam/Imemodela
NúmeroModello/Modellneve/ Название модели /
Názovmodelu/Imemodela/Denumiremodel/
Наименование модели /Nazwa modelu

TTX07

Modellnummer/Number/Numérodumodele
Numero/ Номерна модели/modello
Číslo modelu/Modellszám/Első számú
Številka modela/ Număr model /Broj modela
Modellnummer/Numemodellu

1563-001-01

Type/Tipo/Típus/Typ/Тип /Tip

001

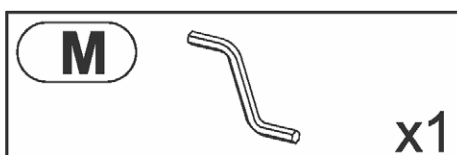
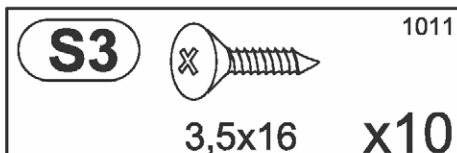
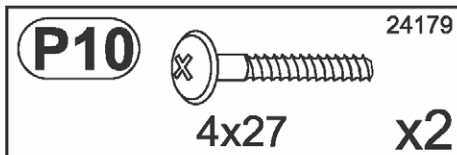
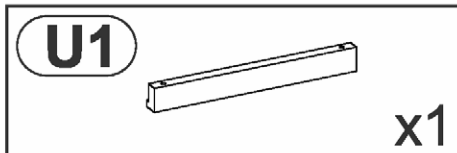
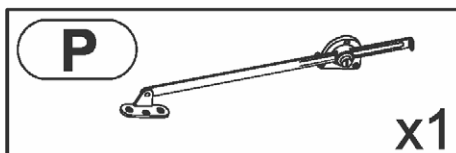
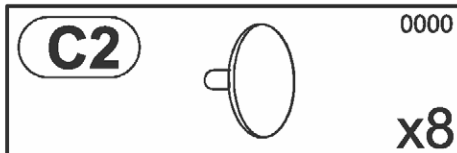
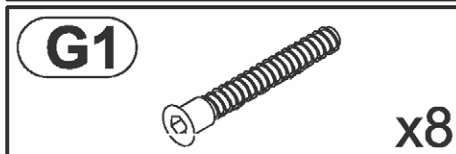
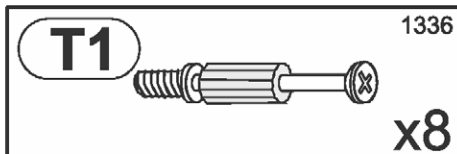
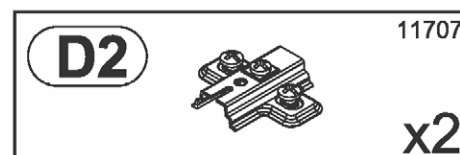
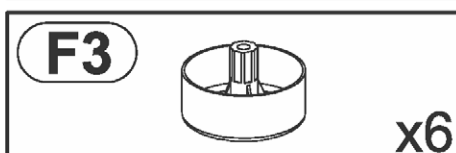
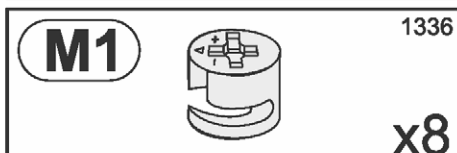
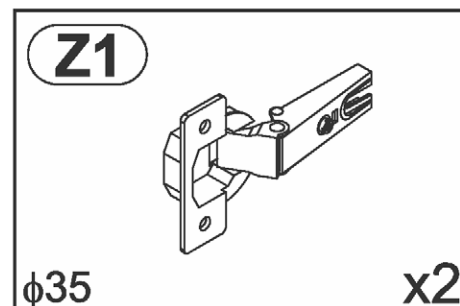
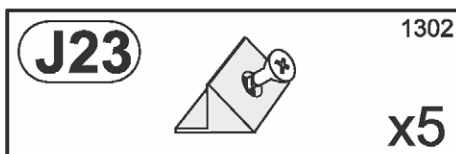
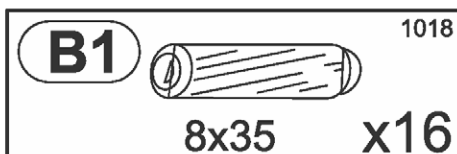

1

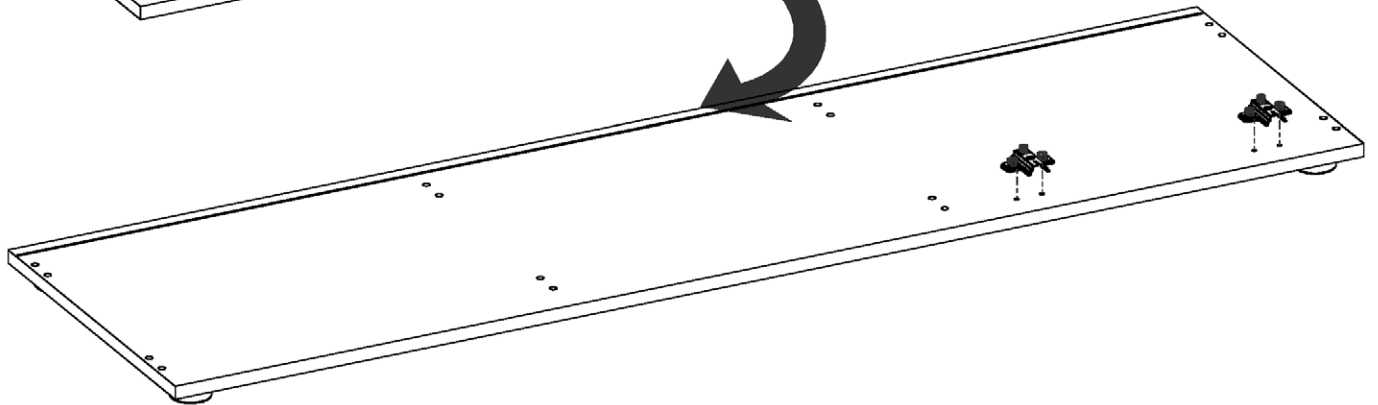
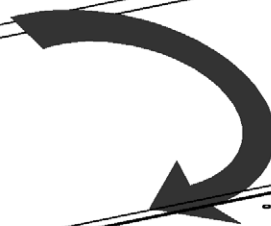
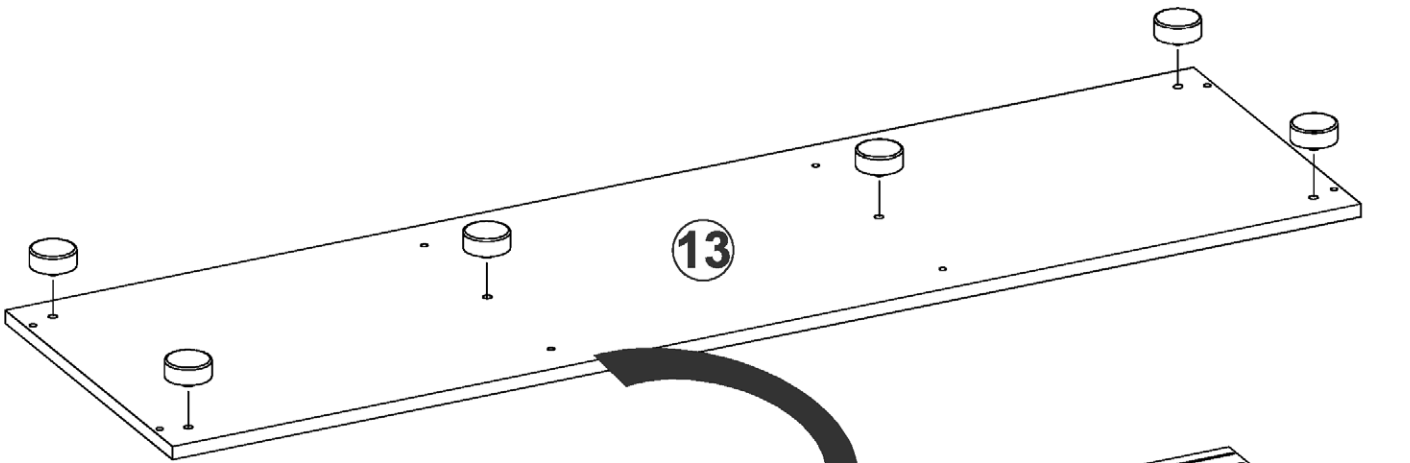
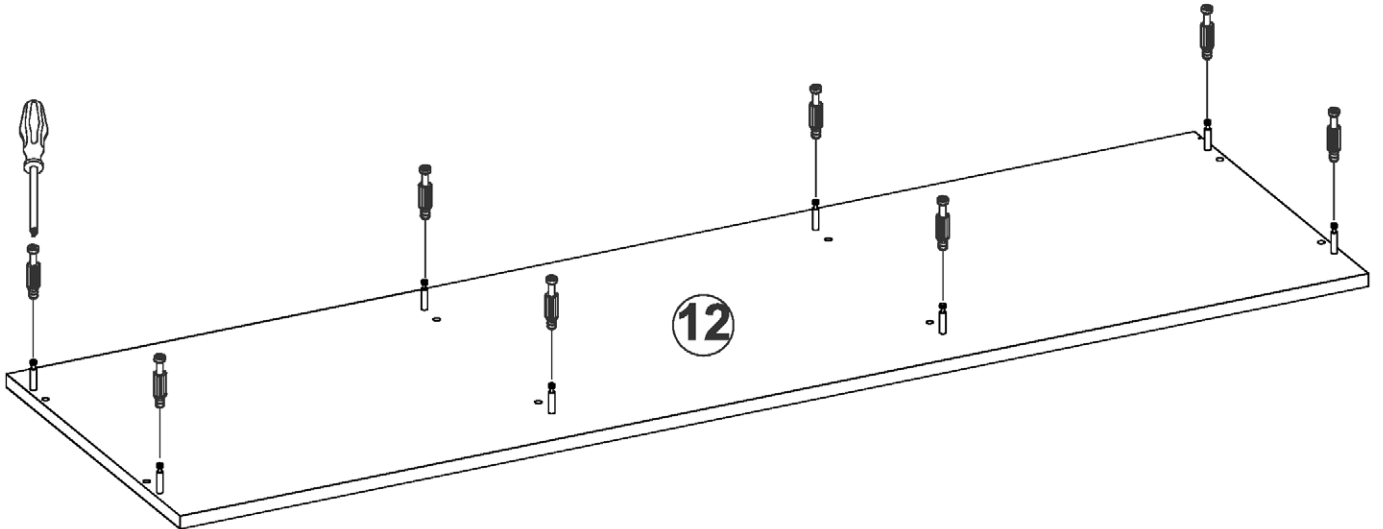
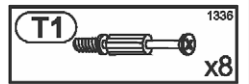
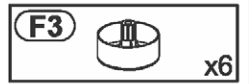
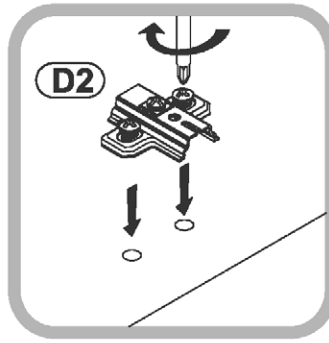
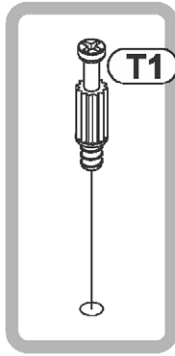
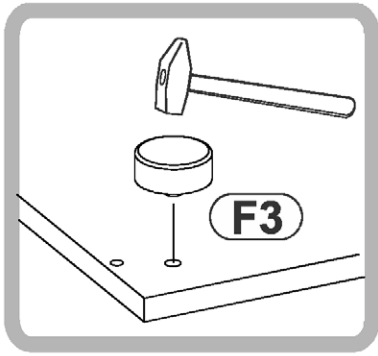

2

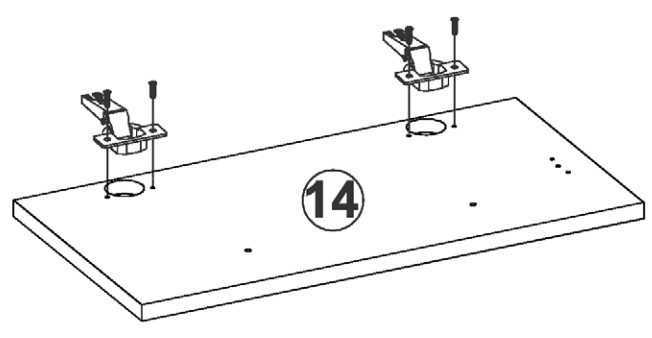
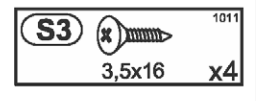
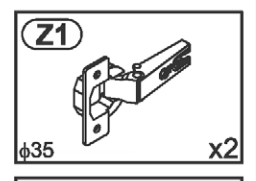
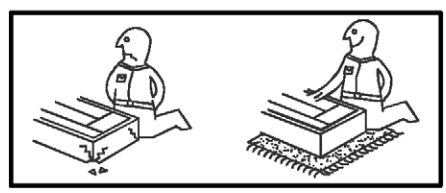
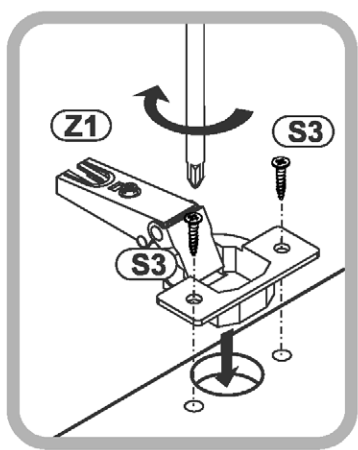
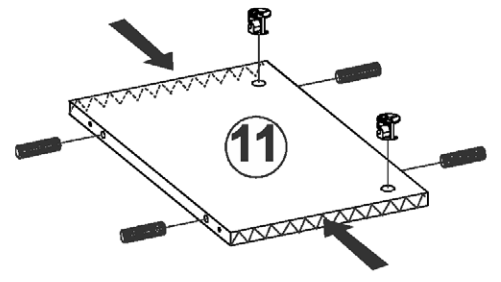
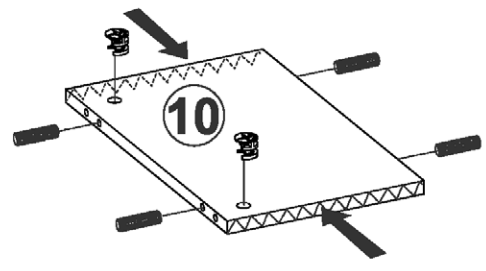
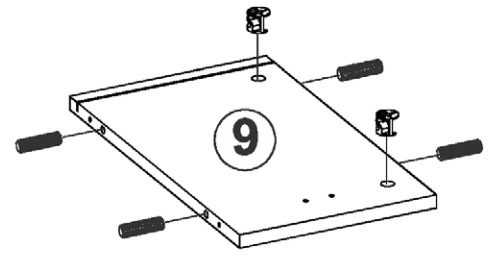
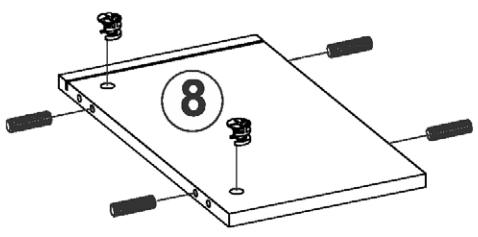
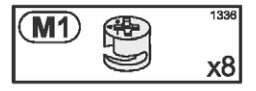
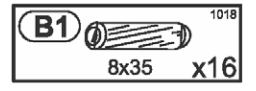
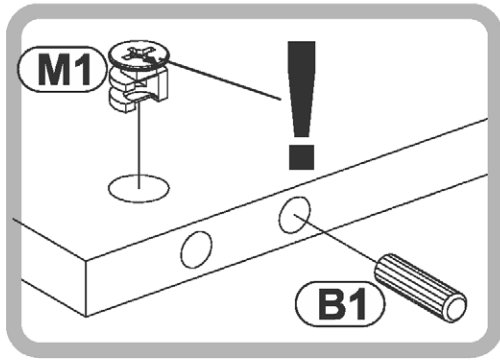

3

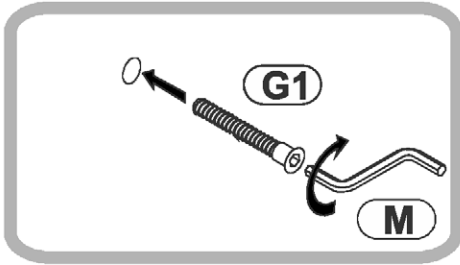

G1		x8
M		x1

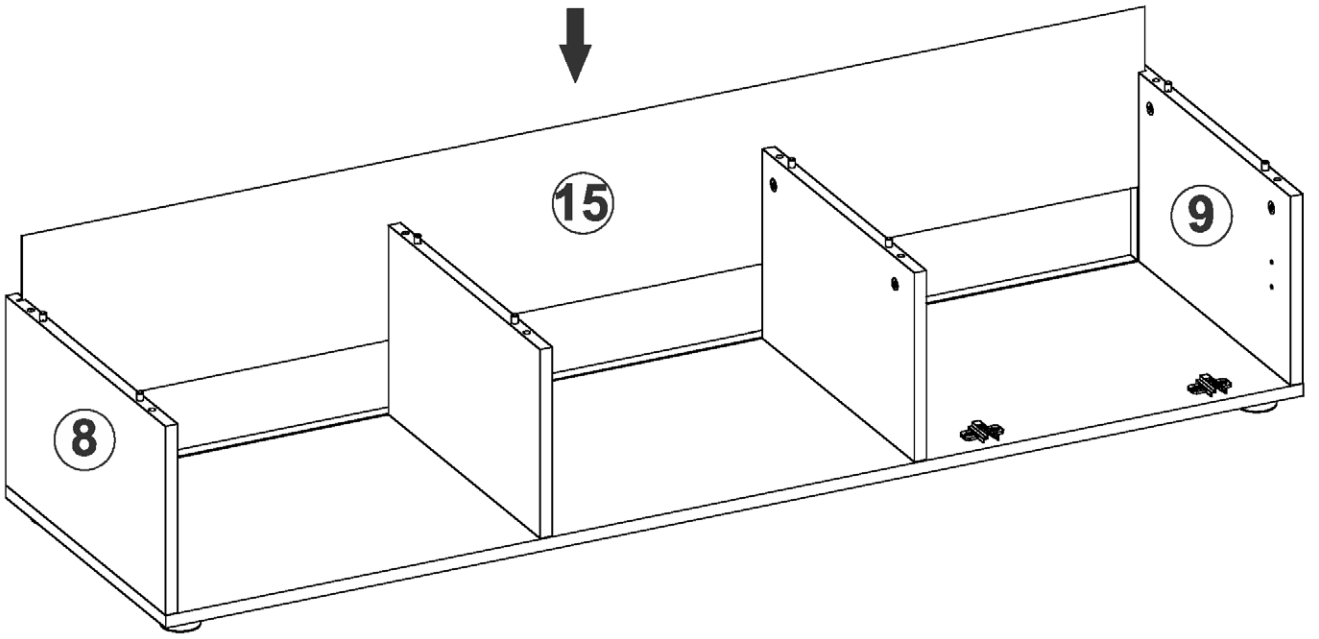
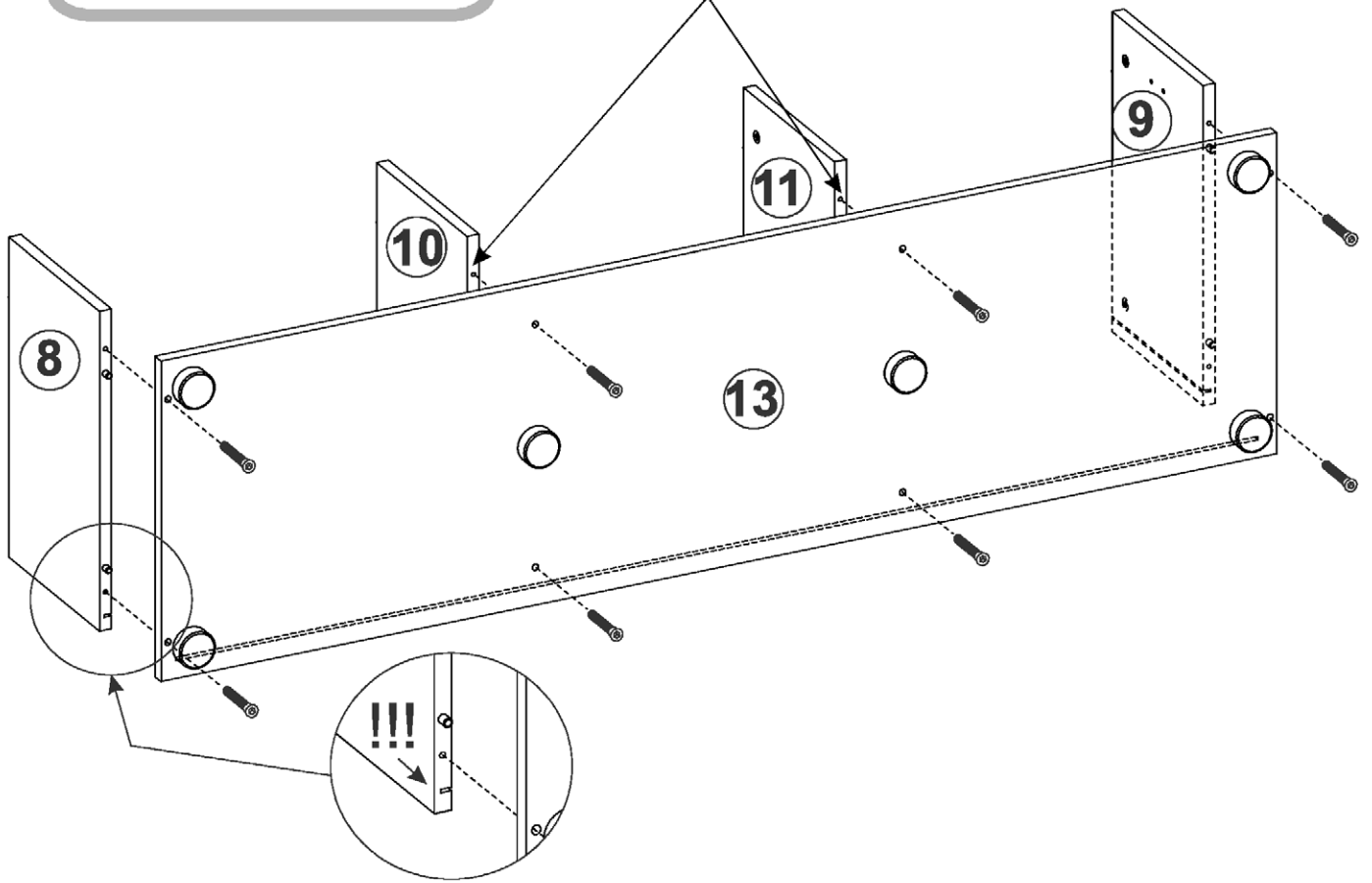
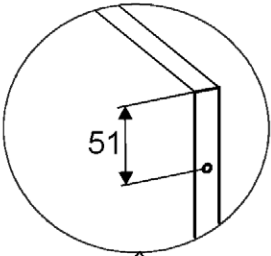

4

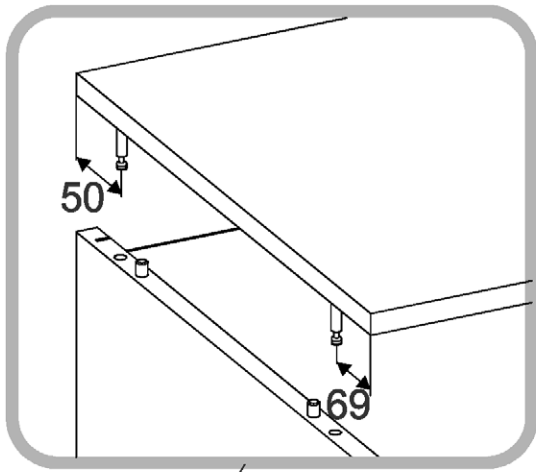

A

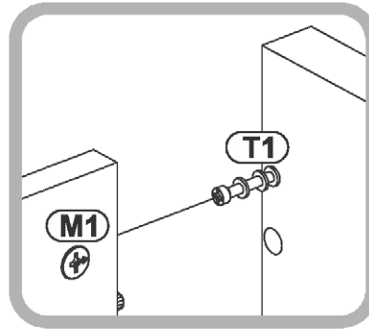

B

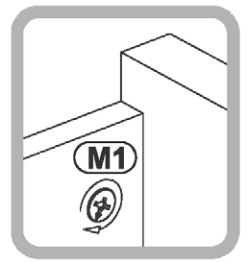

12

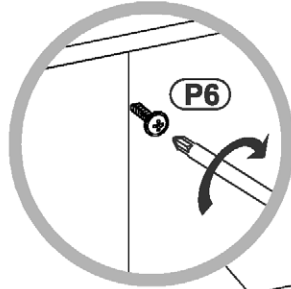
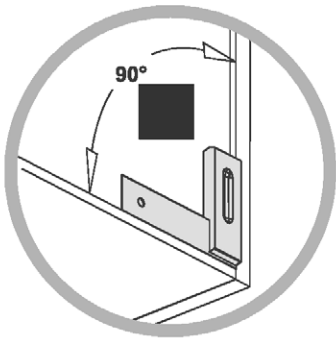
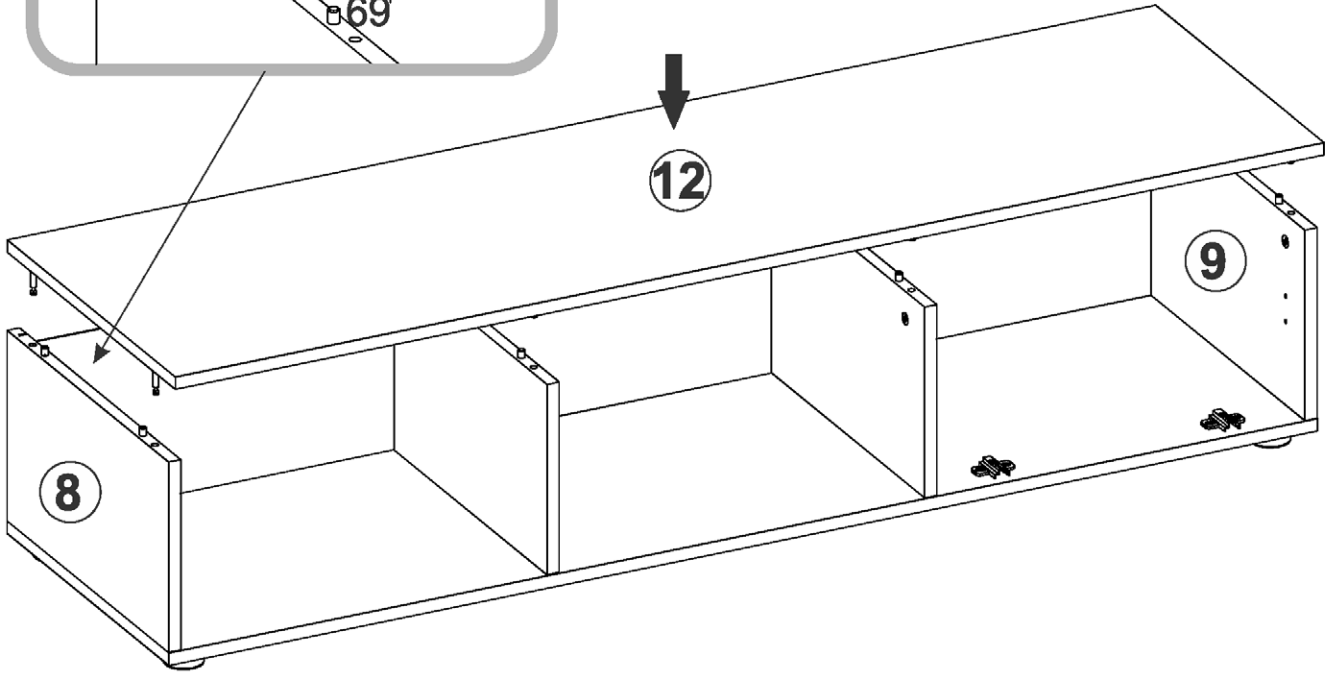

J23		1302
		x5
P6		4x16
		x6

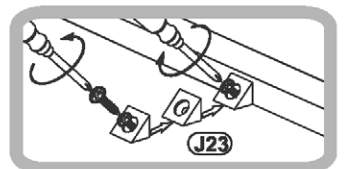
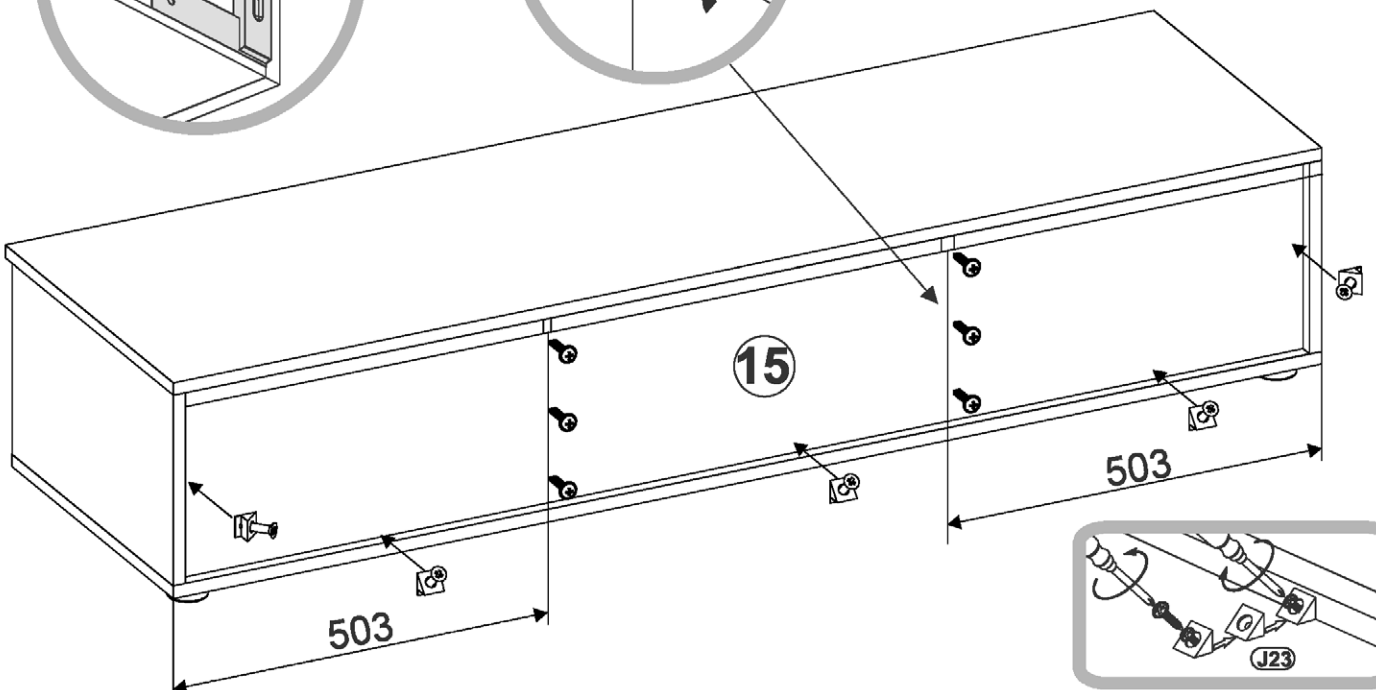

5

1.

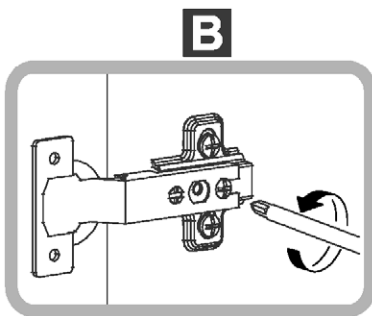
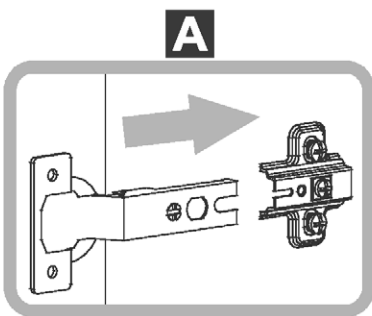

2.

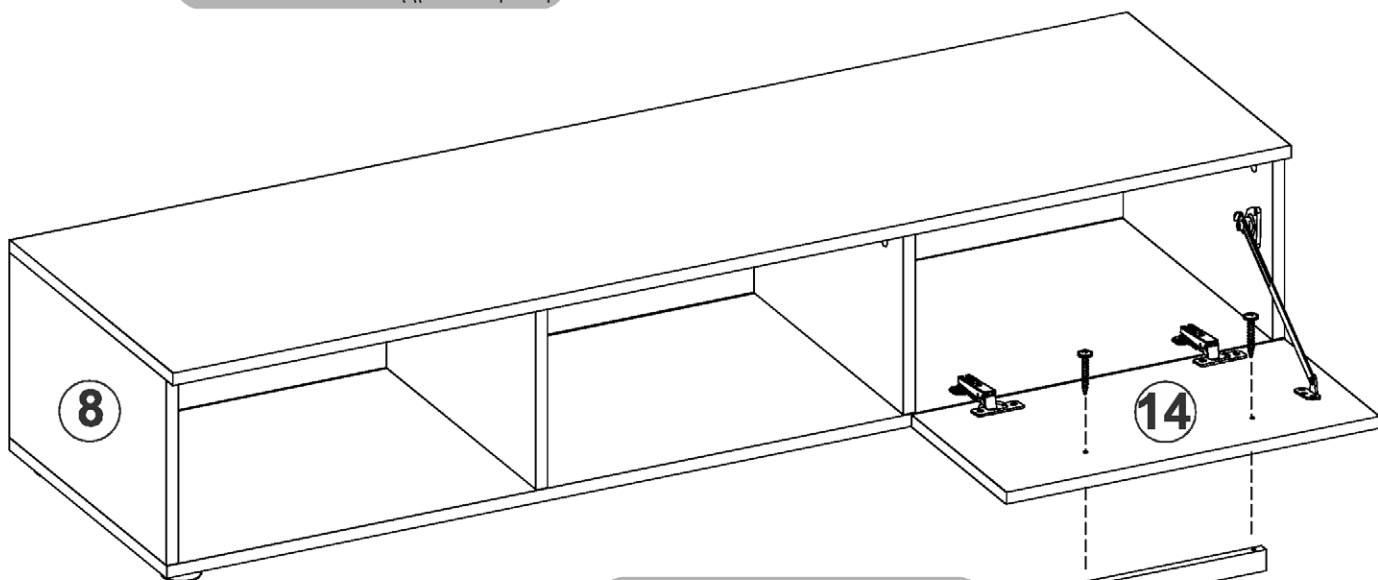
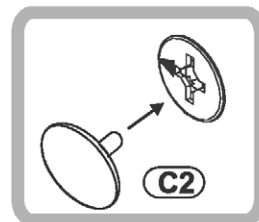
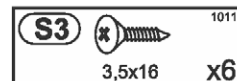
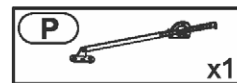
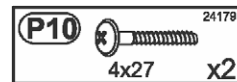
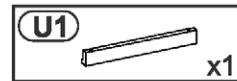
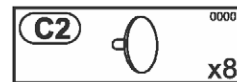
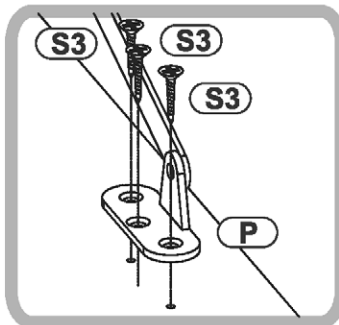
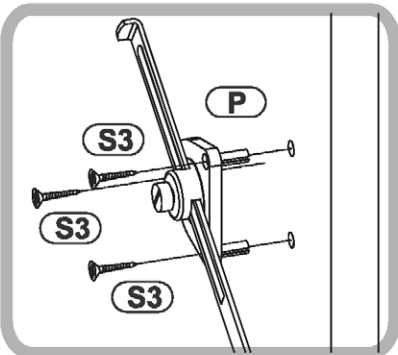

3.

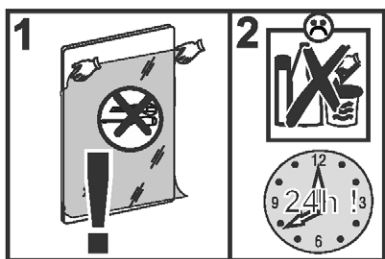

4.

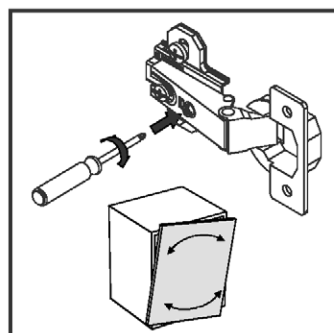
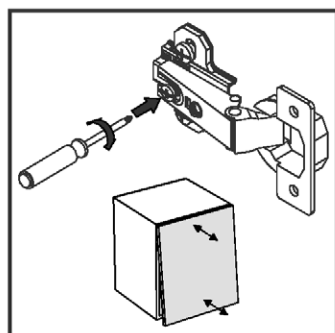
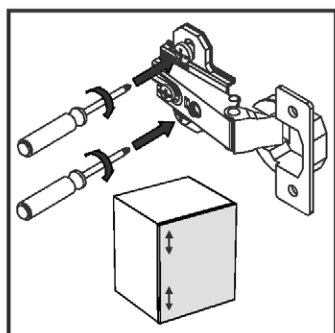
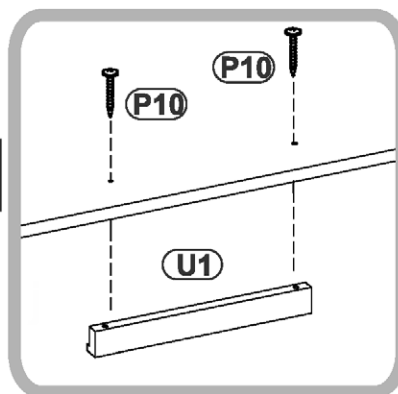

LKZ 80152

Modellname/Modelname/Nomdumodele/Modellnamn
 Nomemodello/Názvmodelu/Modelnaam/Imemodella
 NuméroModello/Modellineve/ Названиемодели /
 Názovmodelu/Imemodella/Denumiremodel/
 Наименованиемодела /Nazwamodelu

TTX07

Modellnummer/Number/Numérodumodele
 Numero/ Номернамодела/modello
 Číslomodelu/Modellszáma/Elslomodelu
 Številkamodela/ Numämodel /Brojmodela
 Modelnummer/Numemodellu

1563-001-01

Type/Тipo/Тípus/Тур/Тип /Tip

001

D Unser Direktservice für Beschlagteile
 Sollte Ihnen ein Beschlagteil fehlen, können Sie diese Servicekarte direkt an die untenstehende Adresse mailen. Wir können allerdings nur Beschlagteile auf diesem Wege verschicken. Sollten Sie eine andere Beanstandung an Ihrem Möbelstück haben, so wenden sie sich bitte direkt an Ihr Möbelhaus.

GB Our direct order service for fitting
 If a fitting part is missing, you can e-mail this service card directly to the address below. However, we can only send fitting parts in this way. If you have any other cause for complaint concerning your item of furniture, please contact your furniture store directly.

CZ Naše přímé služby pro kování
 Chybí-li vám nějaký díl z kování, můžete tuto servisní kartu odeslat e-mailem přímo na níže uvedenou adresu. Touto cestou však můžeme rozeslat jen díly kování. Pokud byste reklamovali jiný díl nábytku, obraťte se přímo na svého prodejce nábytku.

F Bien étudier la notice de montage
 S'il vous manque une ferrure, veuillez envoyer directement la présente carte service à l'adresse e-mail indiquée ci-dessous. Cependant, ceci nous permet uniquement d'envoyer des ferrures. Pour tout autre type de réclamation concernant votre meuble, veuillez contacter directement votre magasin d'ameublement.

I Il nostro servizio diretto per l'ordine della ferramenta
 Qualora Vi dovesse mancare un pezzo di fissaggio, allora Vi preghiamo di inviare questa carta di servizio immediatamente all'indirizzo sottostante. Possiamo inviare i pezzi di fissaggio solamente per mezzo di questo procedimento. Qualora dovete avere qualche altra reclamazione in merito al mobile, allora Vi preghiamo di rivolgerVi direttamente al Vostro Negozio di mobili.

BG Нашата директна услуга за обкова
 Ако липсват части от комплекта, потърнете настоящата сервисна карта и ни я изпратете на e-mail адреса, посочен по-долу. По този начин можем да доставяме само липсващи елементи от обкова. Ако установите други дефекти по мебелите, Ви съветваме да се обвърнете към мебелната къща/магазин, от който сте закупили стоката.

NL Onze directservice voor losse onderdelen
 Wanneer er een onderdeel ontbreekt, kunt u deze servicekaart direct aan onderstaand e-mailadres sturen. Wij kunnen langs deze weg echter alleen beslagdelen versturen. Mocht u een ander probleem aan uw meubel hebben, verzoeken wij u contact op te nemen met uw meubeldealer.

PL Nasz bezpośredni serwis części montażowych
 Jeżeli brakuje części końcowych do montażu, prosimy o przesłanie nam niniejszej karty serwisowej na niżej podany adres e-mailowy. W ten sposób możemy przelać Państwu tylko brakujące części. W przypadku innych reklamacji dotyczących mebla, prosimy zgłosić się do salonu meblowego, w którym został dokonany zakup.

HR Servis za okove
 U slučaju da nedostaje neki od dijelova molimo vas da na dolje navedenu mail adresu pošaljete ovaj servisni obrazac. Na ovaj način mogu se dostaviti samo okovi. U slučaju da imate dodatne prigovore vezane uz komad namještaja molimo vas da se obratite izravno trgovini namještaja gdje je isti kupljen.

HU Direktszolgáltatunk vasalatok esetén
 Ha hiányzik egy vasalat, ezt a kártyát közvetlenül elküldheti az alább található címre. Azonban csak vasalatok tudunk így küldeni. Amennyiben másfajta reklamáció áll fenn bútoráruját illetően, forduljon közvetlenül a bútorházhoz.

SK Náš priamy servis pre časti kovania
 Ak by Vám chýbala nejaká časť kovania, môžete poslať túto servisnú kartu poslať e-mailom na nižšie uvedenú adresu. Diely kovania vieme poslať iba týmto spôsobom. Ak by ste mali inú reklamáciu ohľadom Vášho nábytku, obráťte sa priamo na Vašu predajňu nábytku.

SLO Naše direktne uslužne storitve za okovje
 Če vam manjka kakšno okovje, lahko to servisno kartico pošljete po e-pošti direktno na spodnji naslov. Po tej poti vam lahko pošljemo samo okovje. Če želite reklamirati kakšen drug del pohištva, se obrnite neposredno na vašo trgovino pohištva.

RO Service-ul nostru direct pentru feronerie
 În cazul în care vă lipsește o piesă de feronerie puteți să trimiteți direct acest card de service prin e-mail la adresa de mai jos. Noi nu putem expedia piese de feronerie decât pe această cale. Dacă aveți o altă reclamație referitoare la piesa de mobilier, atunci vă rugăm să vă adresați direct la magazinul dvs. de mobilă.

RUS Наш прямой сервис для поставок фурнитуры
 Если окажется, что Вам не хватает того или иного элемента фурнитуры, Вы можете отправить сервисную карту по факсу непосредственно на нижеприведенный адрес электронной почты. Однако, таким образом мы можем пересылать лишь фурнитуру. Если же у Вас возникнут иные претензии относительно приобретенной мебели, пожалуйста, обращайтесь непосредственно в организацию, осуществляющую продажу.

S Vår direktservice för beslagdelar
 Om du saknar en beslagdel kan du skicka detta servicekort direkt till e-postadressen som anges nedan. Tänk på att detta är den enda möjligheten att skicka beslagdelar till dig. Om du vill reklamera din möbel av en annan anledning måste du kontakta ditt möbelhus direkt.

ES Nuestro servicio directo para accesorios
 Si le falta algún accesorio, puede enviar esta tarjeta de servicio directamente a la siguiente dirección. No obstante, por este método solo podemos enviar accesorios. Si tiene alguna otra objeción sobre su mueble, consulte directamente con su mueblería.

TR Donatılar için doğrudan servisimiz
 Bir donatınız eksikse bu servis kartını doğrudan aşağıda bulunan adrese doğrudan mail yazabilirsiniz. Sadece bu yolla donatılar gönderiliriz. Mobilyanızda başka şikayetleriniz varsa lütfen doğrudan mobilya satıcınıza danışın.

max.

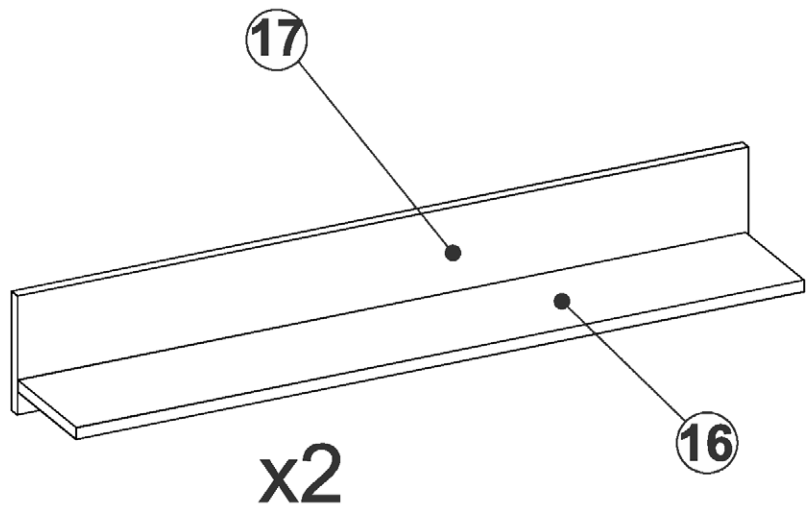

Colli 3

Colli 2

16 17

16 17

16	7014349
17	7014350

Grunder/Beanstandung/Reasonoftheobjection:

Möbelhaus/Furniturestore:

Name/Nom: Telefon/Telephone:

PLZ/Banksortingcode: Ort/City:

Strasse/Street:

Haus-Nr./HouseNo.: @E-Mail:

LKZ 80152

Modellname/Modelname/Nomdumodele/Modellnamn
Nomemodello/Názevmodelu/Modelnaam/Imemodela
NúmeroModello/Modellneve/ Названиемодели /
Názovmodelu/Imemodela/Denumiremodel/
Наименованиемодела /Nazwaodelu

TTX07

Modellnummer/Number/Numérodumodele
Numero/ Номернамодела/modello
Čísliomodelu/Modellszáma/Elsiomodelu
Številkamodela/ Numärrmodel /Brojmodela
Modellnummer/Numemodellu

1563-001-01

Type/Типо/Тípus/Тур/Тип /Tip

001

B1 x2

G1

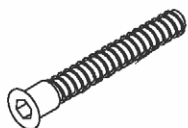

x4

M



x1

L2



x2

C2



5x11

x4

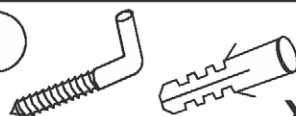

I2





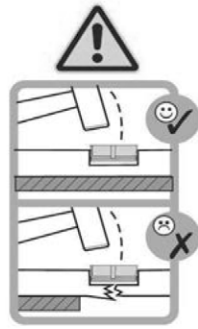
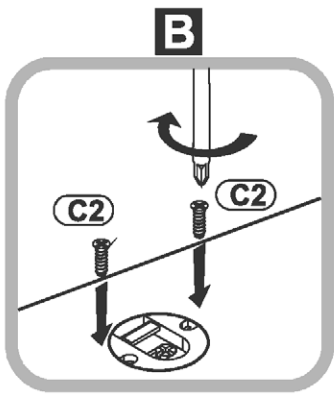
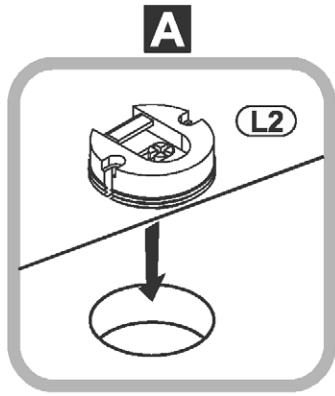

x2

1

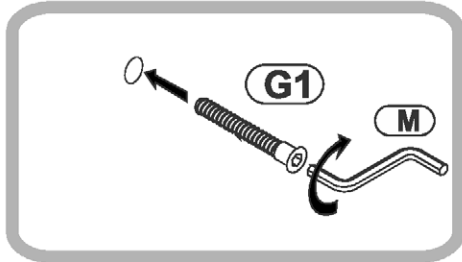
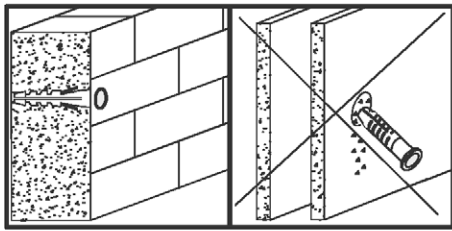
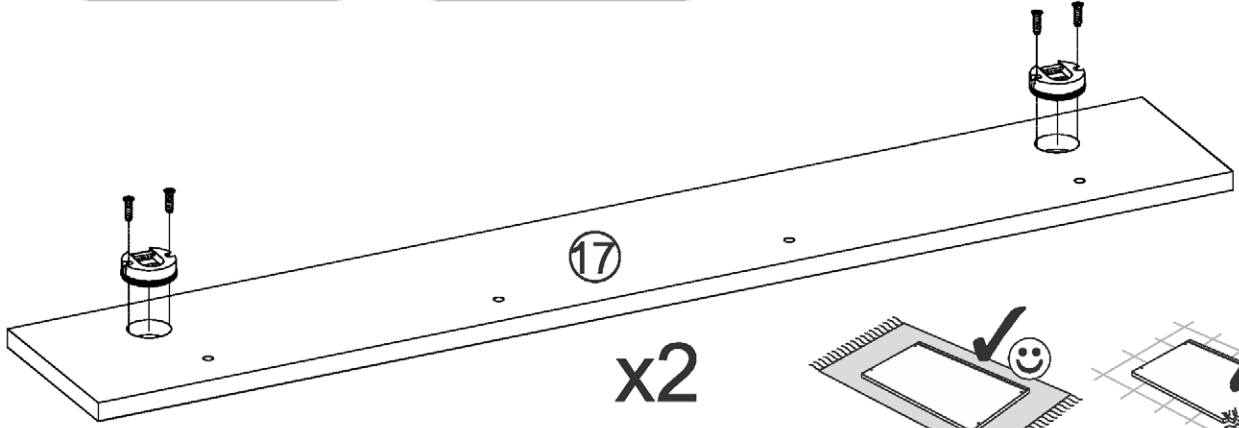

- L2**  x2
- C2**  5x11 x4



- G1**  x4
- M**  x1
- I2**  x2

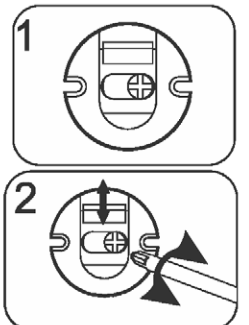
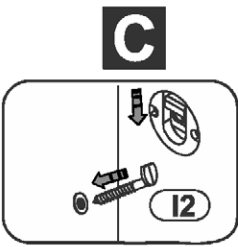
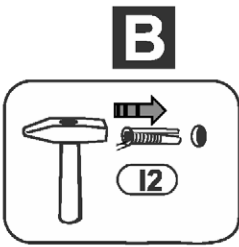
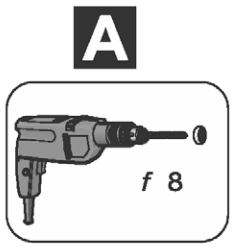
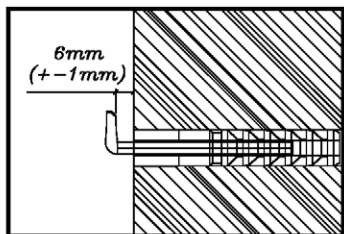
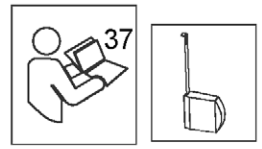
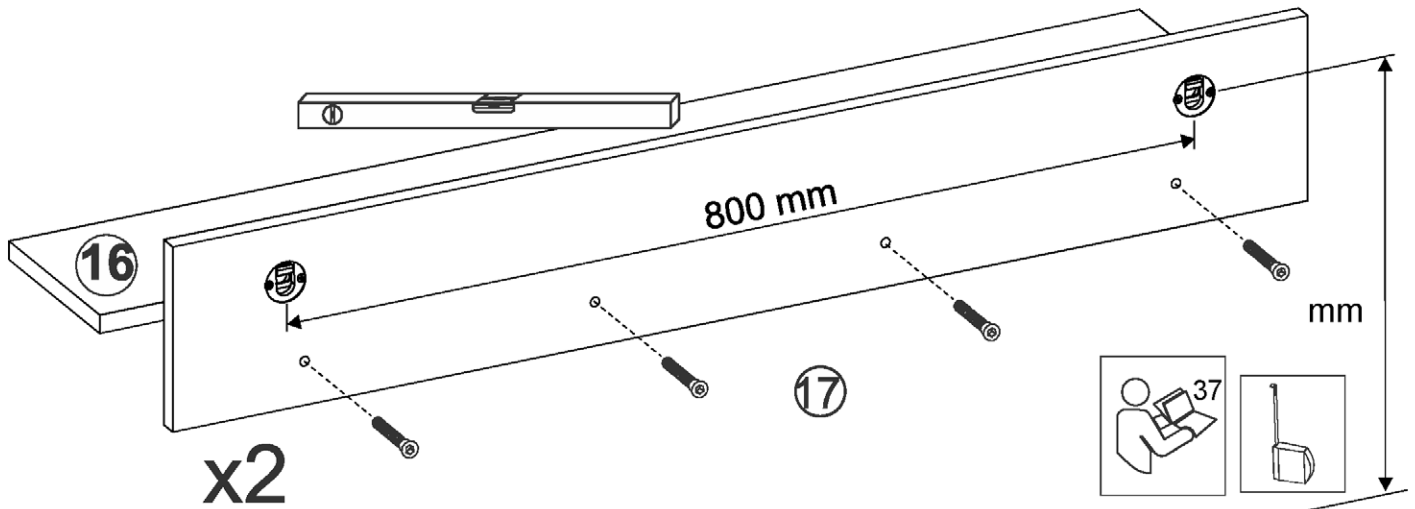

LKZ 80152

Modellname/Modelname/Nomdumodele/Modellnamn
Nomemodello/Názvmodelu/Modelnaam/Imemodella
NuméroModello/Modellineve/ Названиemodeli /
Názovmodelu/Imemodella/Denumiremodel/
Наименованиemodela /Nazwamodelu

TTX07

Modellnummer/Number/Numérodumodele
Numero/ Номернамодела/modello
Čísloemodelu/Modellszáma/Elsloemodelu
Števílkamodela/ Numämodel /Brojmodela
Modelnummer/Numemodellu

1563-001-01

Type/Тipo/Тípus/Тур/Тип /Tip

001

D Unser Direktservice für Beschlagteile
Sollte Ihnen ein Beschlagteil fehlen, können Sie diese Servicekarte
direkt an die untenstehende Adresse mailen. Wir können allerdings
nur Beschlagteile auf diesem Wege verschicken. Sollten Sie eine
andere Beanstandung an Ihrem Möbelstück haben, so wenden sie
sich bitte direkt an Ihr Möbelhaus.

GB Our direct order service for fitting
If a fitting part is missing, you can e-mail this service card directly
to the address below. However, we can only send fitting parts in
this way. If you have any other cause for complaint concerning
your item of furniture, please contact your furniture store directly.

CZ Naše přímé služby pro kování
Chybí-li vám nějaký díl z kování, můžete tuto servisní kartu odeslat
e-mailem přímo na níže uvedenou adresu. Touto cestou však
můžeme rozesílat jen díly kování. Pokud byste reklamovali jiný díl
nábýtku, obraťte se přímo na svého prodejce nábýtku.

F Bien étudier la notice de montage
S'il vous manque une ferrure, veuillez envoyer directement la présente
carte service à l'adresse e-mail indiquée ci-dessous. Cependant, ceci
nous permet uniquement d'envoyer des ferrures. Pour tout autre type
de réclamation concernant votre meuble, veuillez contacter
directement votre magasin d'ameublement.

I Il nostro servizio diretto per l'ordine della ferramenta
Qualora Vi dovesse mancare un pezzo di fissaggio, allora Vi
preghiamo di inviare questa carta di servizio immediatamente
all'indirizzo sottostante. Possiamo inviare i pezzi di fissaggio
solamente per mezzo di questo procedimento. Qualora dovete
avere qualche altra reclamazione in merito al mobile, allora Vi
preghiamo di rivolgerVi direttamente al Vostro Negozio di mobili.

BG Нашата директна услуга за обкоа
Ако липсват части от комплекта, потърнете настоящата
сервисна карта и ни я изпратете на e-mail адреса, посочен
по-долу. По този начин можем да доставяме само липсващи
елементи от обкоа. Ако установите други дефекти по
мебелите, Ви съветваме да се обрънете към мебелната
къща/магазин, от който сте закупили стоката.

NL Onze directservice voor losse onderdelen
Wanneer er een onderdeel ontbreekt, kunt u deze servicekaart
direct aan onderstaand e-mailadres sturen. Wij kunnen langs deze
weg echter alleen beslagdelen versturen. Mocht u een ander
probleem aan uw meubel hebben, verzoeken wij u contact op te
nemen met uw meubeldealer.

PL Nasz bezpośredni serwis części montażowych
Jeżeli brakuje części koniecznych do montażu, prosimy o przesłanie
nam niniejszej karty serwisowej na niżej podany adres e-mailowy.
W ten sposób możemy przesyłać Państwu tylko brakujące części.
W przypadku innych reklamacji dotyczących mebla, prosimy zgłosić
się do salonu meblowego, w którym został dokonany zakup.

HR Servis za okove
U slučaju da nedostaje neki od dijelova molimo vas da na dolje
navedenu mail adresu pošaljete ovaj servisni obrazac. Na ovaj način
mogu se dostaviti samo okovi. U slučaju da imate dodatne prigovore
vezane uz komad namještaja molimo vas da se obratite izravno
trgovini namještaja gdje je isti kupljen.

HU Direktiszolgáltatunk vasalatok esetén
Ha hiányzik egy vasalat, ezt a kártyát közvetlenül elküldheti az
alább található címre. Azonban csak vasalatokat tudunk így
küldeni. Amennyiben másfajta reklamáció áll fenn bútorárbaját
illetően, forduljon közvetlenül a bútorárbához.

SK Náš priamy servis pre časti kovania
Ak by Vám chýbala nejaká časť kovania, môžete poslať
túto servisnú kartu poslať e-mailom na nižšie uvedenú
adresu. Diely kovania vieme poslať iba týmto spôsobom.
Ak by ste mali inú reklamáciu ohľadom Vášho nábýtku,
obraťte sa priamo na Vašu predajňu nábýtku.

SLO Naše direktne uslužne storitve za okovje
Če vam manjka kakšno okovje, lahko to servisno kartico pošljete
po e-pošti direktno na spodnji naslov. Po tej poti vam lahko
pošljemo samo okovje. Če želite reklamirati kakšen drug del
pohištva, se obrnite neposredno na vašo trgovino pohištva.

RO Service-ul nostru direct pentru feroneriele
În cazul în care vă lipsește o piesă de feronerie puteți să trimiteți
direct acest card de service prin e-mail la adresa de mai jos. Noi
nu putem expedia piese de feronerie decât pe această cale.
Dacă aveți o altă reclamație referitoare la piesa de mobilier,
atunci vă rugăm să vă adresați direct la magazinul dvs. de mobilă.

RUS Наш прямой сервис для поставок фурнитуры
Если окажется, что Вам не хватает того или иного элемента
фурнитуры, Вы можете отправить сервисную карту по факсу
непосредственно на нижеприведенный адрес электронной
почты. Однако, таким образом мы можем пересылать лишь
фурнитуру. Если же у Вас возникнут иные претензии относительно
приобретенной мебели, пожалуйста, обращайтесь
непосредственно в организацию, осуществившую продажу.

S Vår direktservice för beslagdelar
Om du saknar en beslagdel kan du skicka detta servicekort direkt
till e-postadressen som anges nedan. Tänk på att detta är den enda
möjligheten att skicka beslagdelar till dig. Om du vill reklamera din
möbel av en annan anledning måste du kontakta ditt möbelhus direkt.

ES Nuestro servicio directo para accesorios
Si le falta algún accesorio, puede enviar esta tarjeta de servicio directamente a
la siguiente dirección. No obstante, por este método solo podemos
enviar accesorios. Si tiene alguna otra objeción sobre su mueble, consulte
directamente con su mueblería.

TR Donatılar için doğrudan servisimiz
Bir donatınız eksikse bu servis kartını doğrudan aşağıda bulunan adrese
doğrudan mail yazabilirsiniz. Sadece bu yolla donatılar gönderiliriz.
Mobilyanızda başka şikayetleriniz varsa lütfen doğrudan mobilya satıcınıza
danışın.

max.

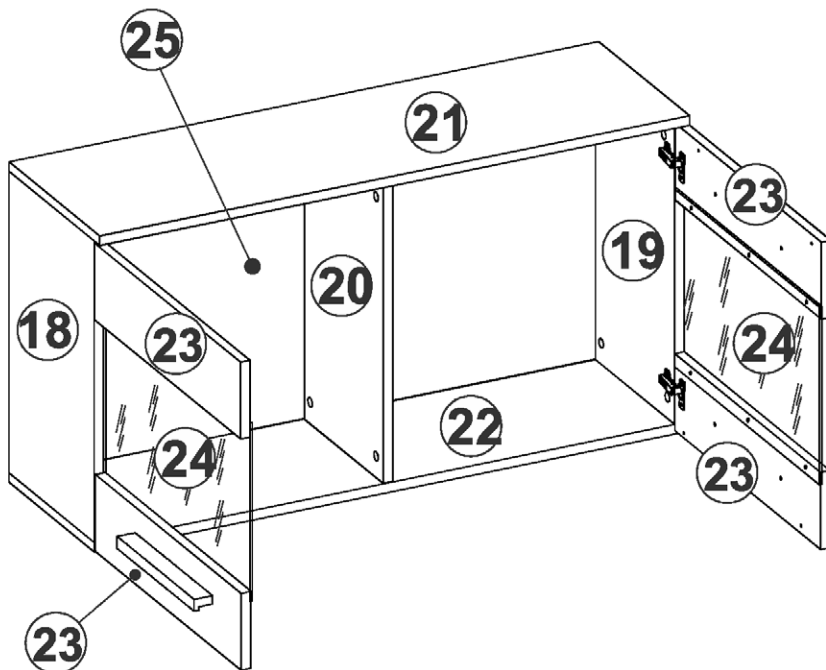

Colli 1

25 22

21 18

19 20

Colli 2

23 23

23 23

24 24

25	7014347
22	7014342
21	7014343
18	7014344
19	7014345
20	7014348
23	7014346
24	3006083

GründerBeanstandung/Reasonoftheobjection:

Möbelhaus/Furniturestore:

Name/Nom:

Telefon/Telephone:

PLZ/Banksortingcode:

Ort/City:

Strasse/Street:

Haus-Nr./HouseNo.:

@E-Mail:

LKZ 80152

Modellname/Modelname/Nomdumodele/Modellnamn
Nomemodello/Názevmodelu/Modelnaam/Imemodela
NúmeroModello/Modellneve/ Названиемодели /
Názovmodelu/Imemodela/Denumiremodel/
Наименованиемодела /Nazwaodelu

TTX07

Modellnummer/Number/Numérodumodele
Numero/ Номернамодела/modello
Číslomodelu/Modellszáma/Elsiomodelu
Številkamodela/ Numärmodel /Brojmodela
Modelnummer/Numemodellu

1563-001-01

Type/Тipo/Тípus/Тур/Тип /Tip

001

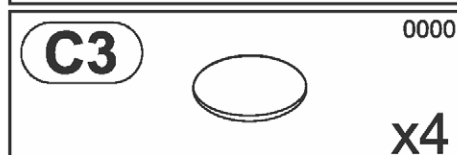
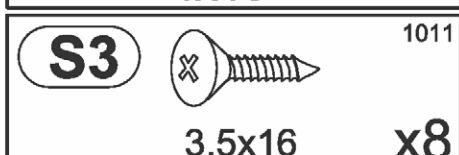
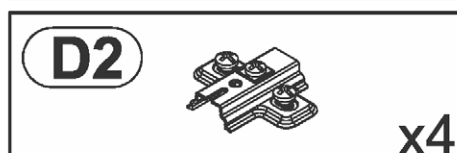
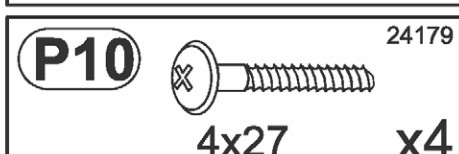
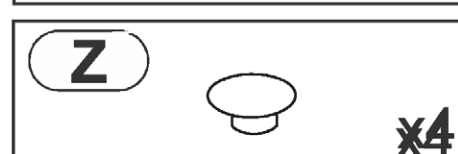
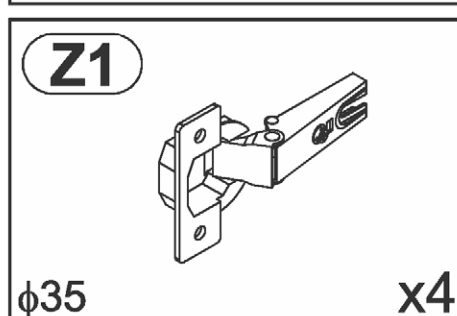
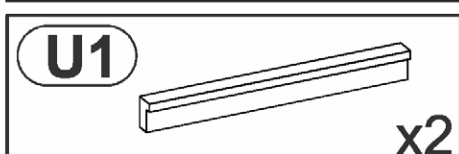
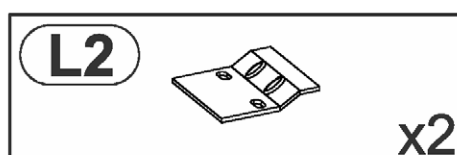
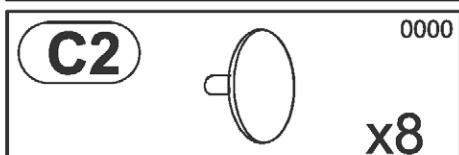
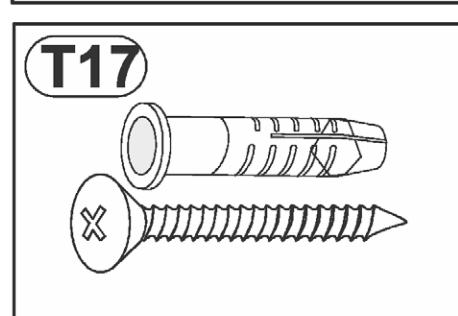
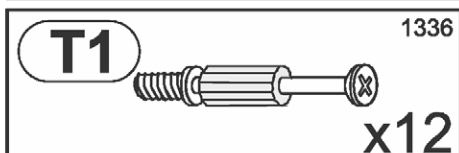
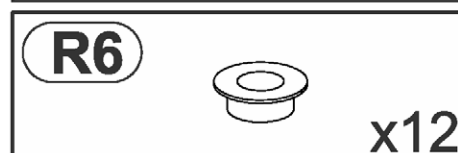
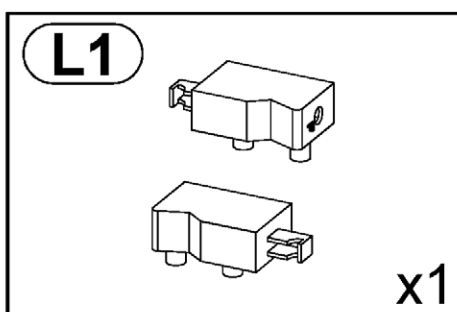
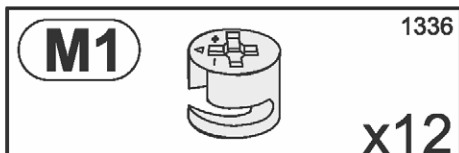
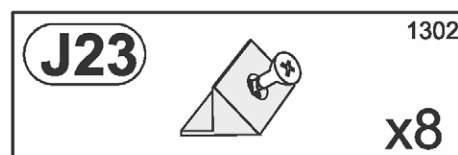
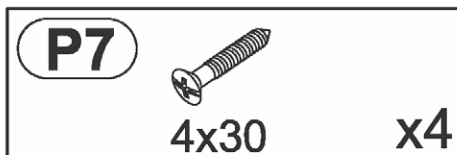
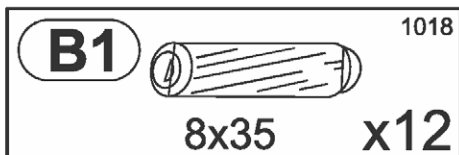

1

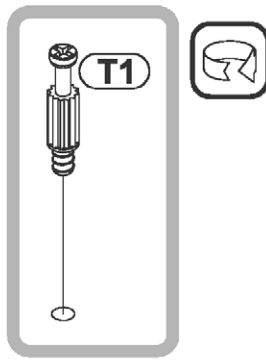
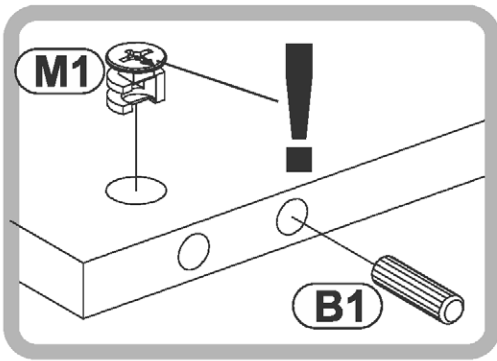

B1 1018
8x35 x12

M1 1336
x12

T1 1336
x12

P7
4x30 x4

L1
x1

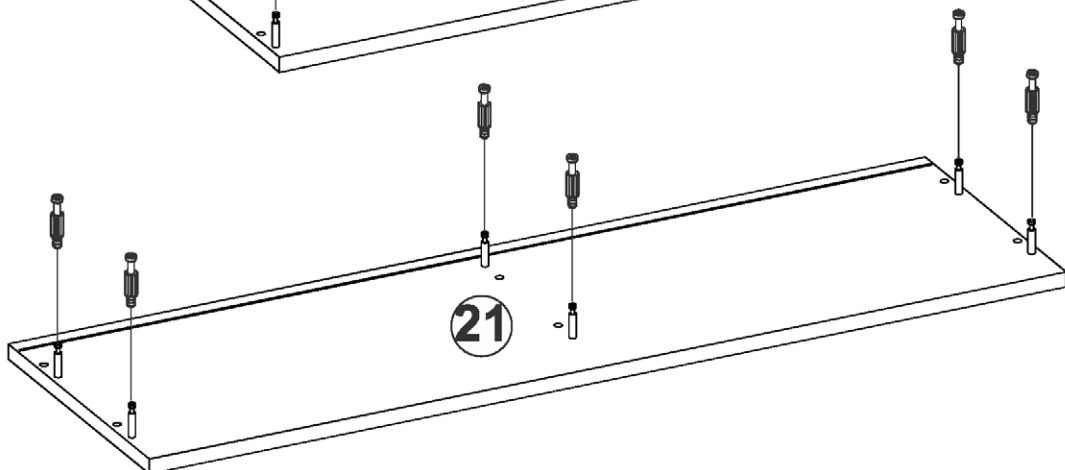
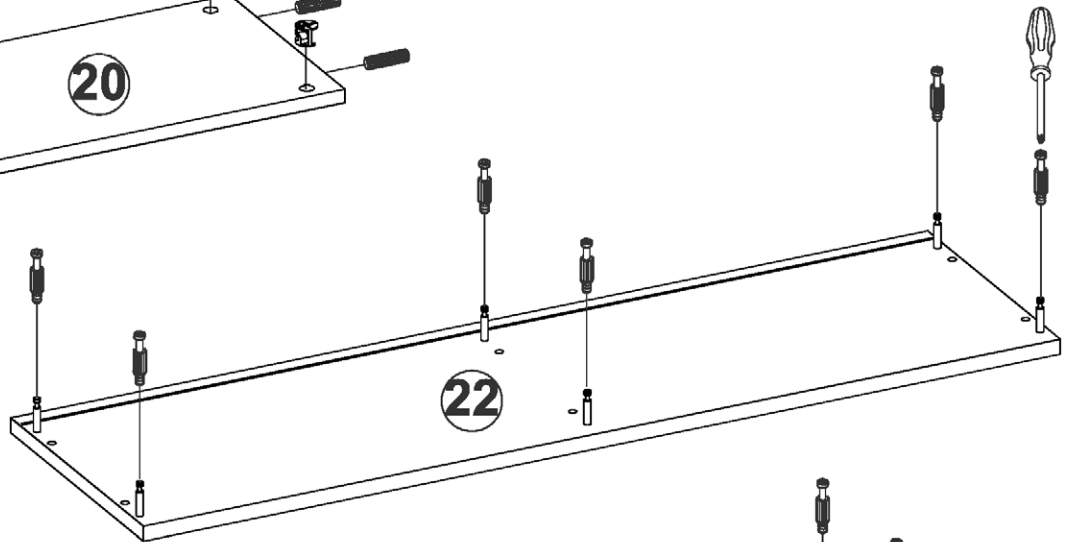
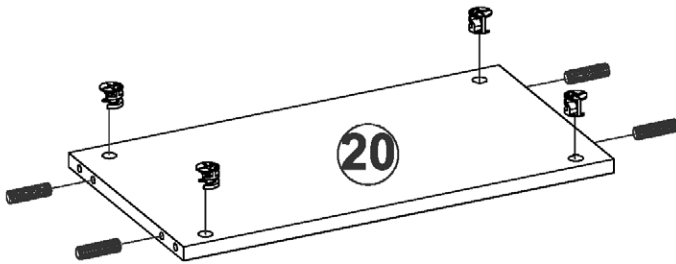
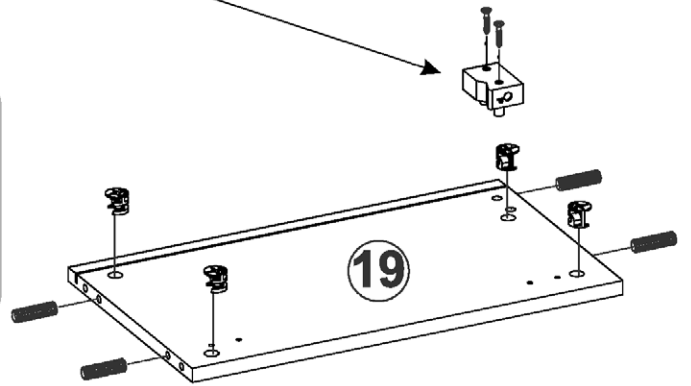
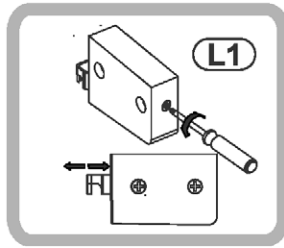
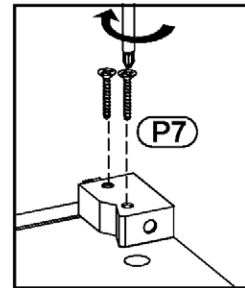
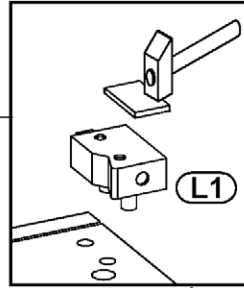
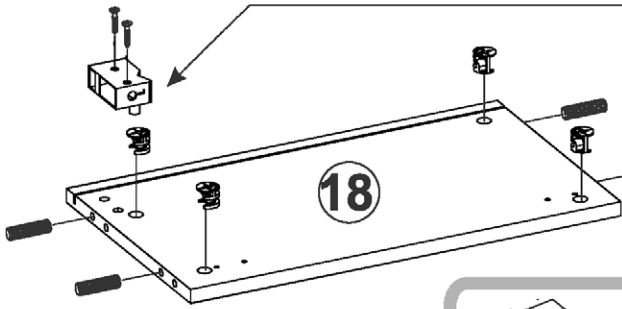

2

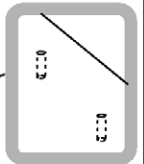
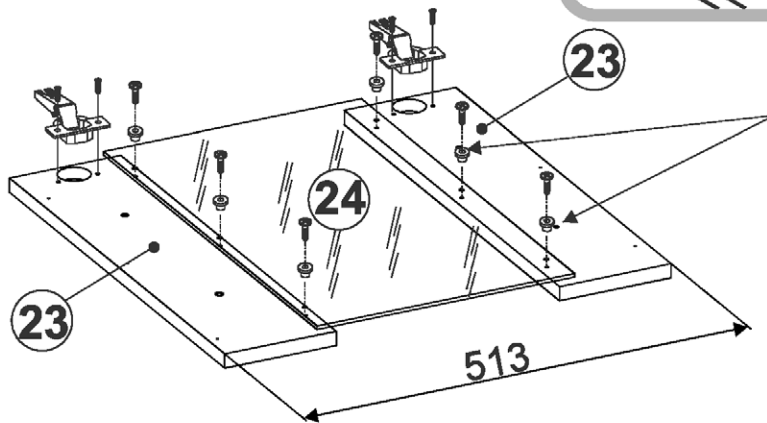
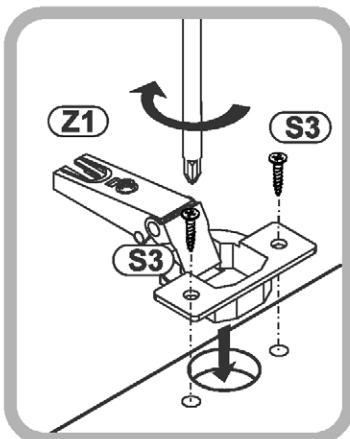
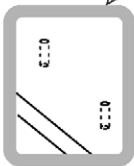
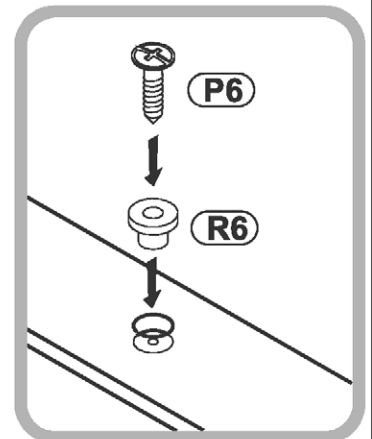
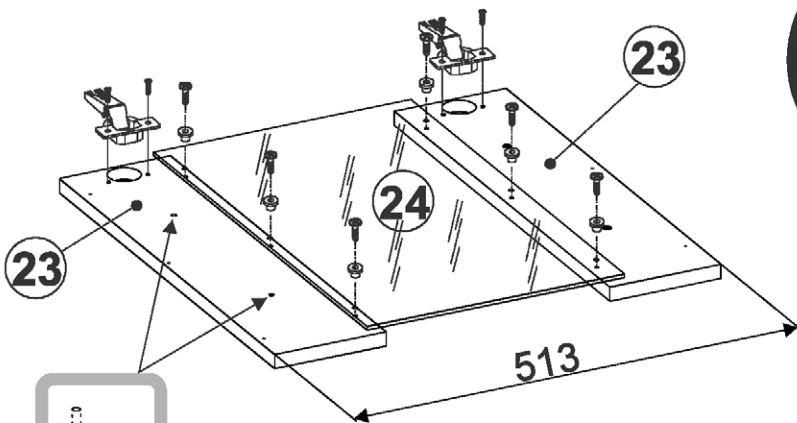
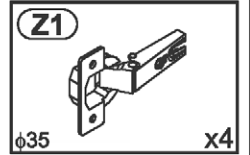
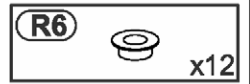
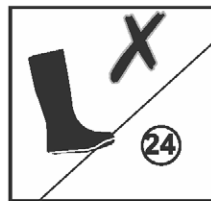
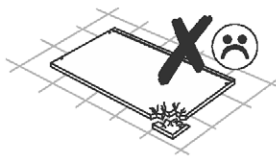
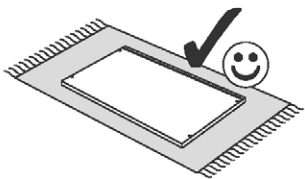
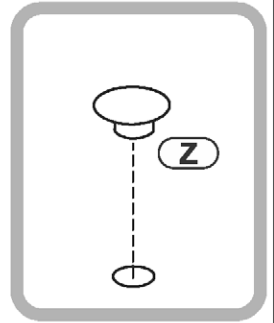
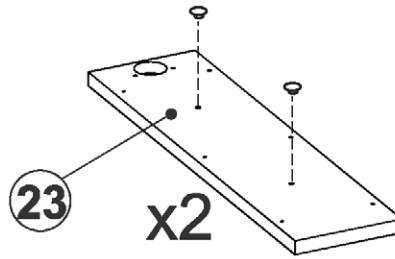
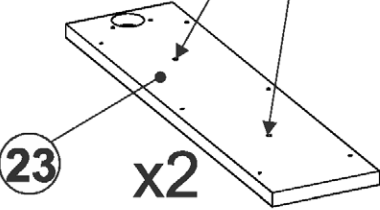
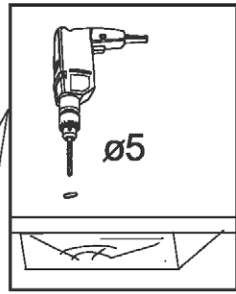

3

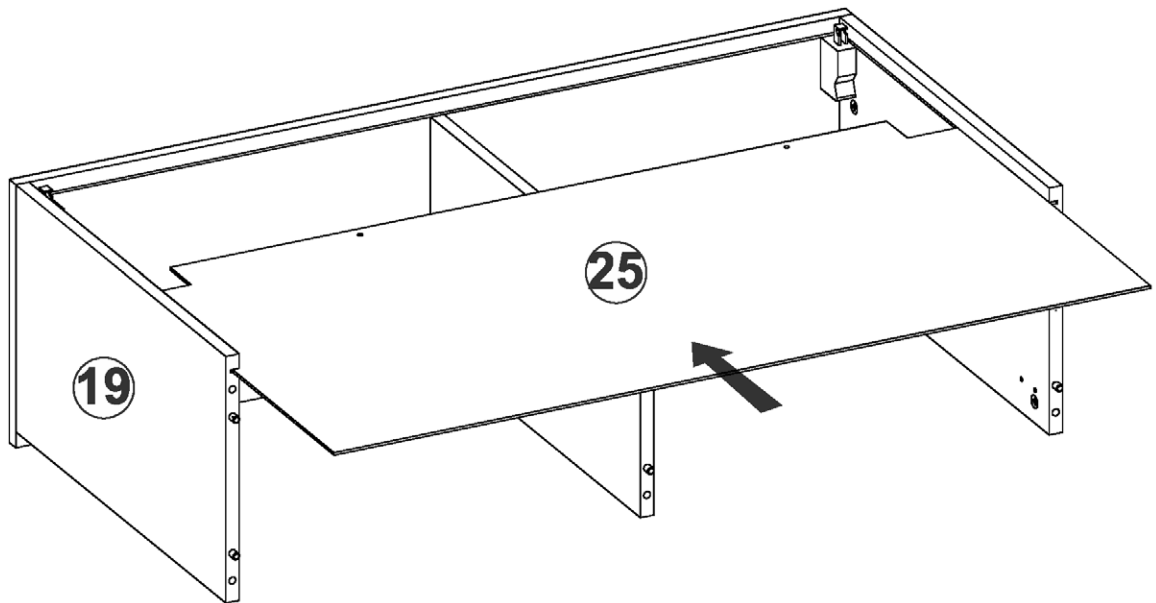
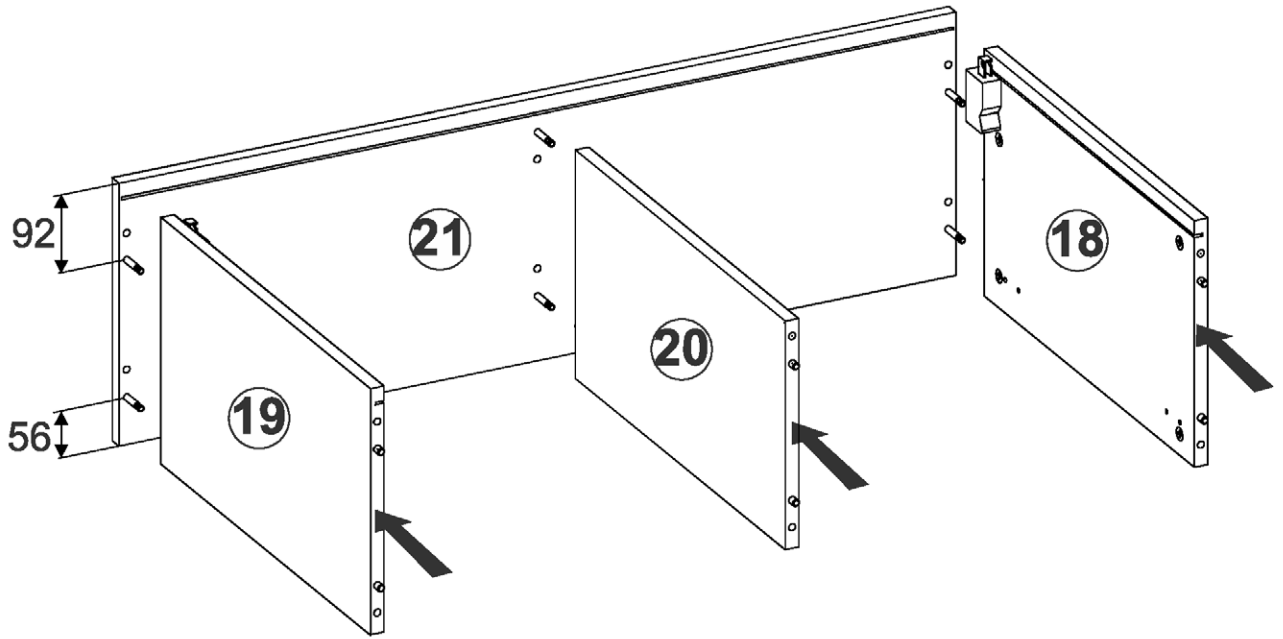
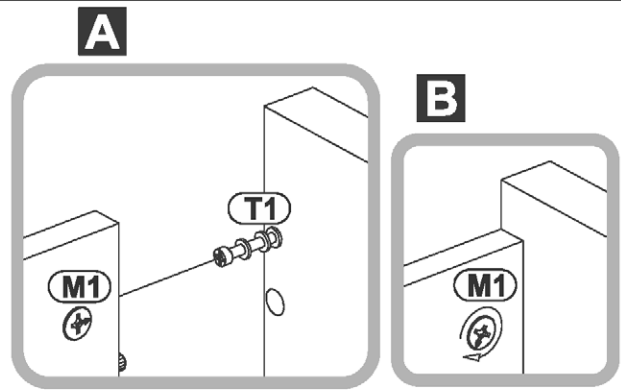

4

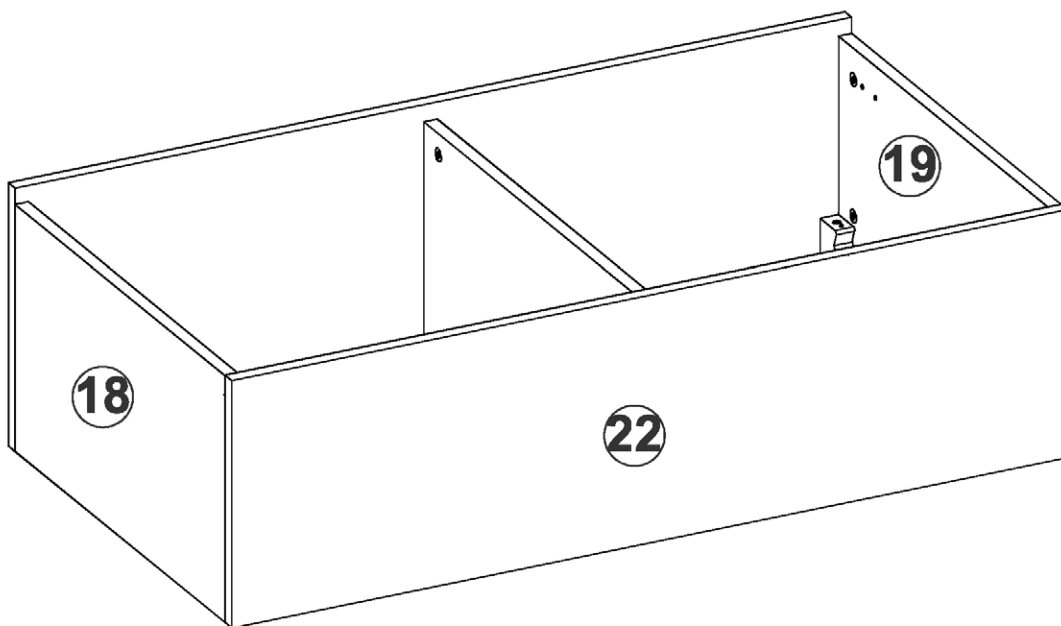
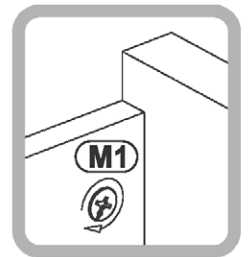
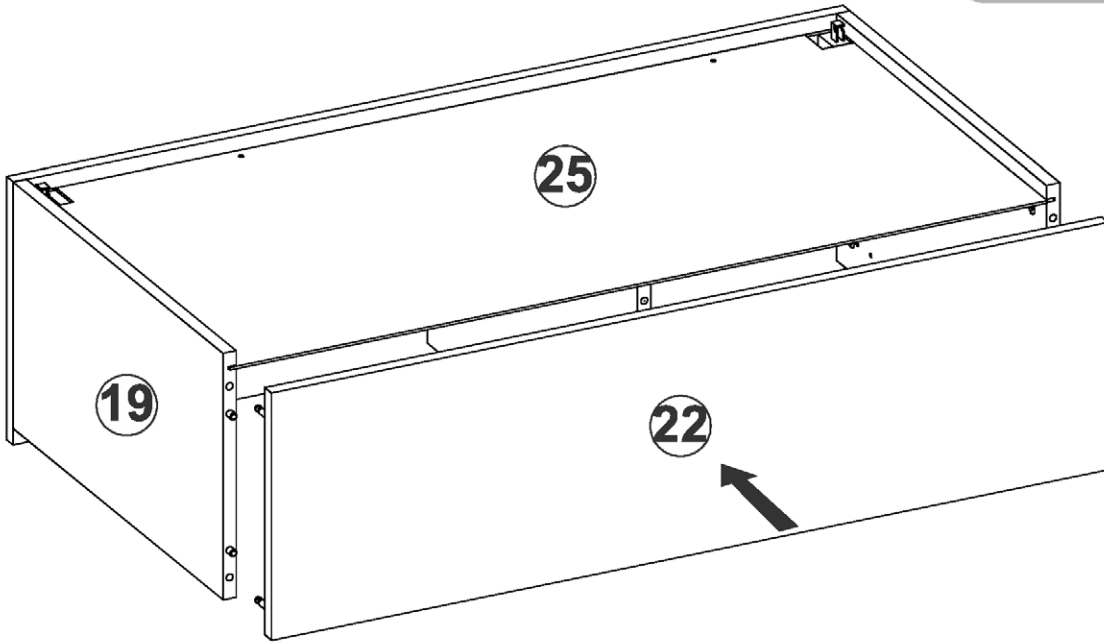
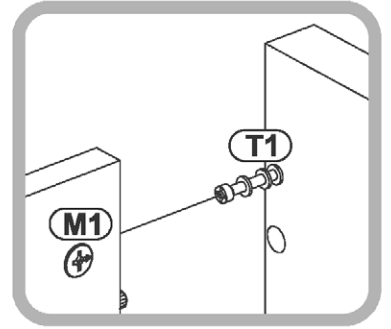

5

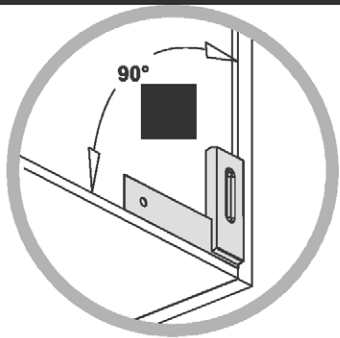

J23 1302
x8

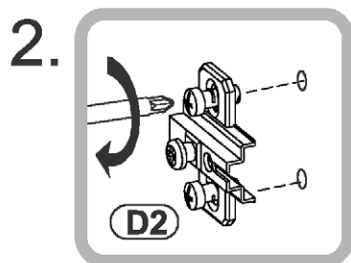
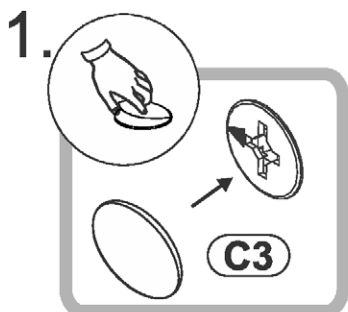
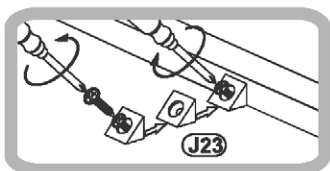
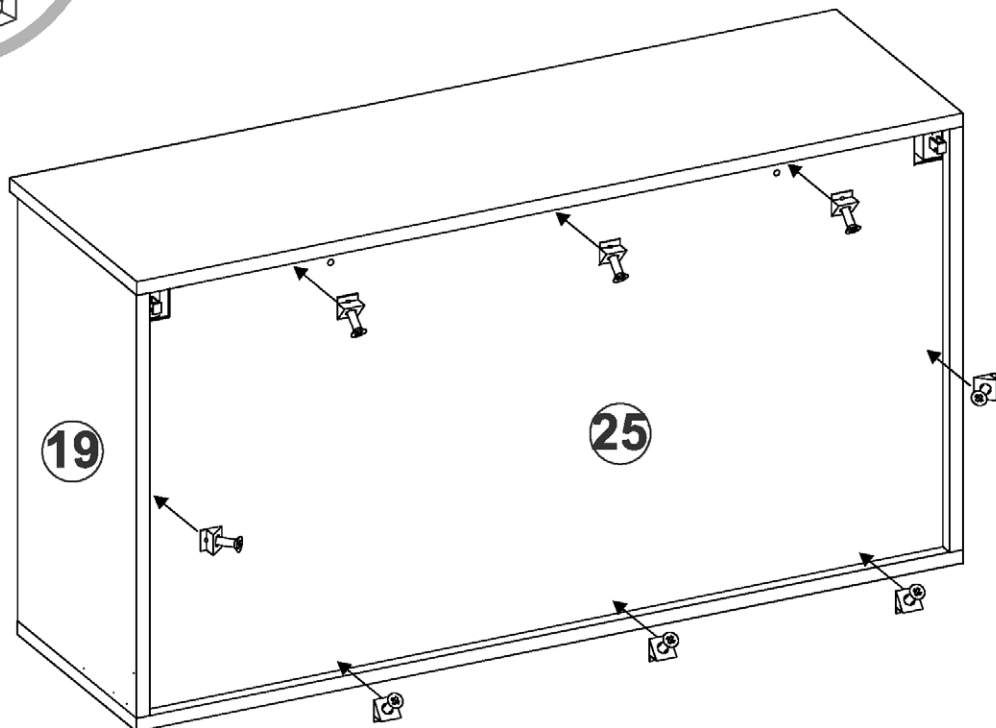

D2 x4

C3 0000
x4

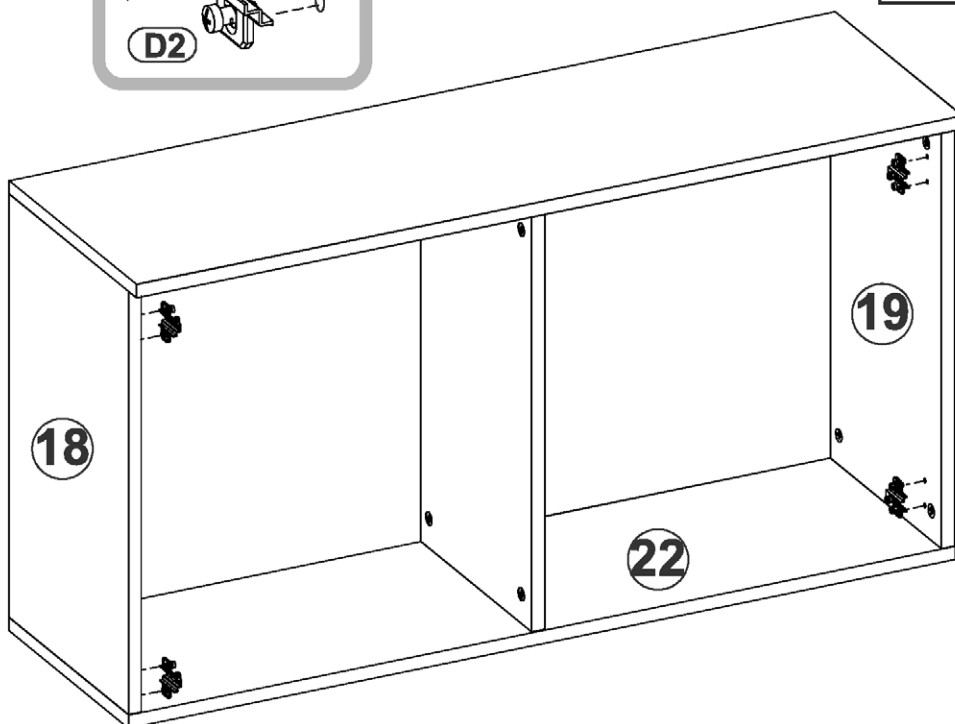
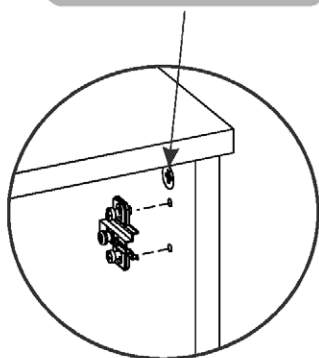

6

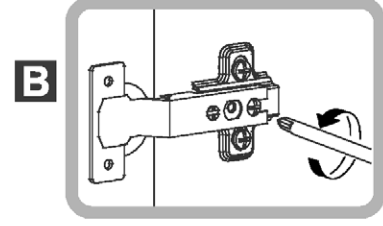
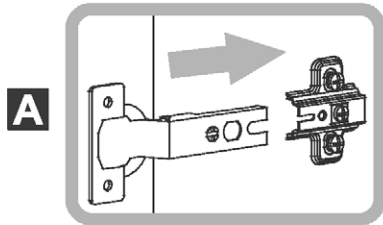

2.

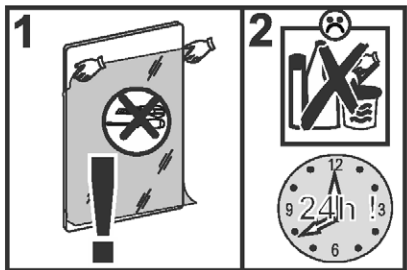

3.

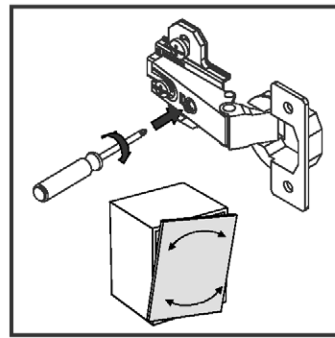
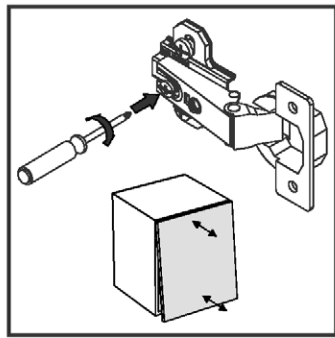
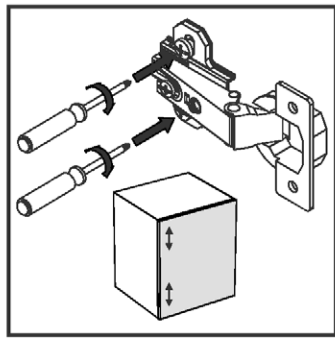
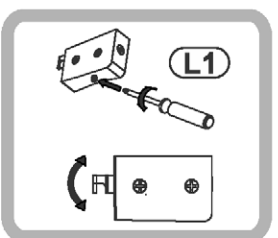
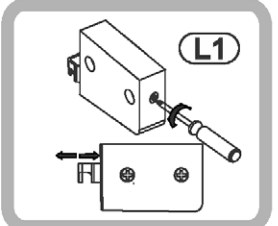
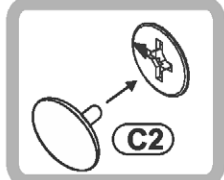
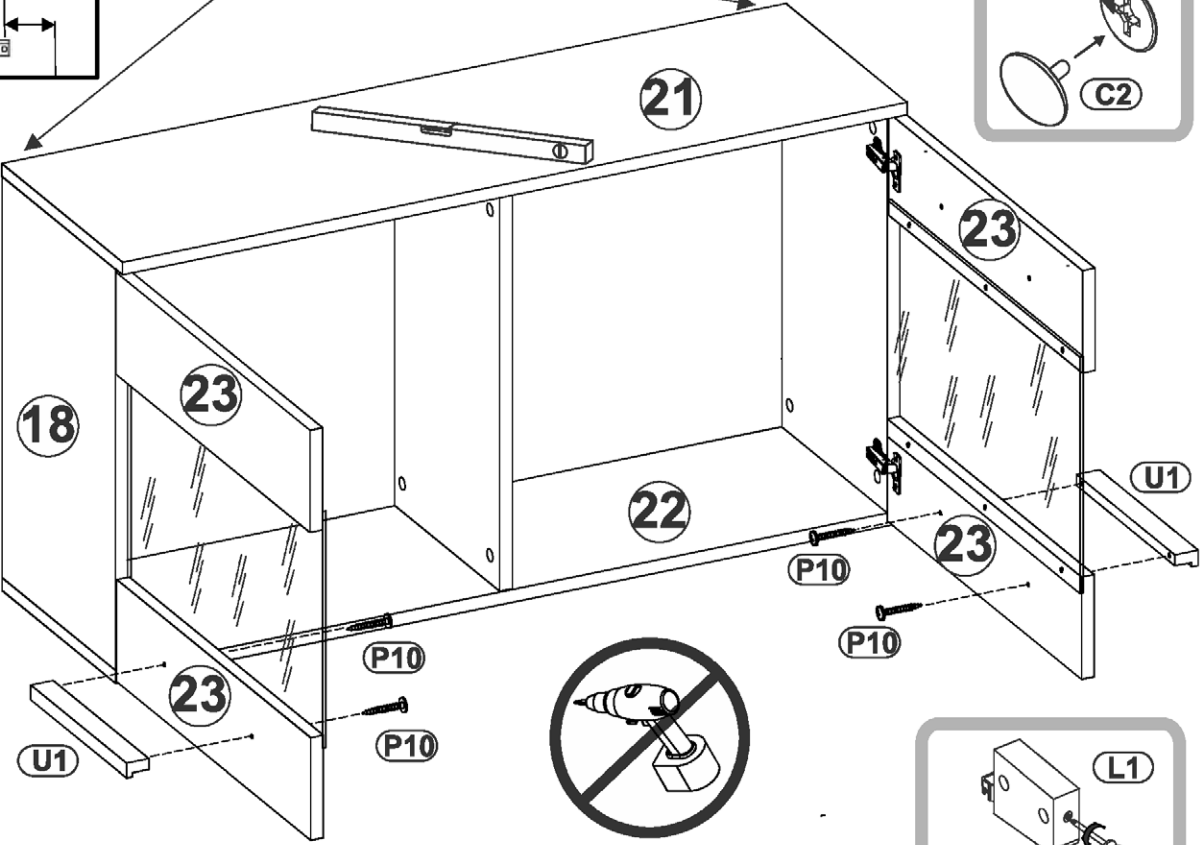
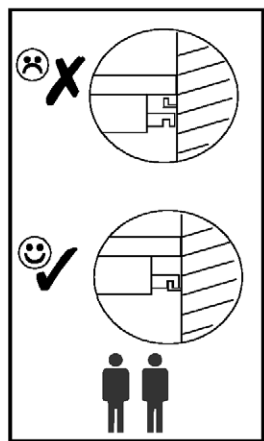
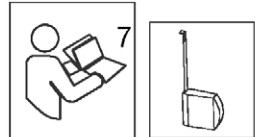
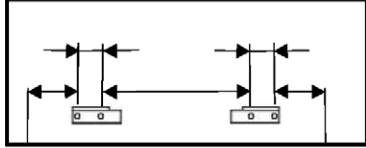
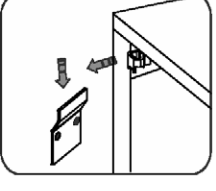
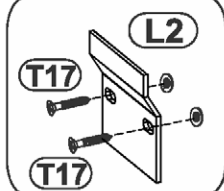
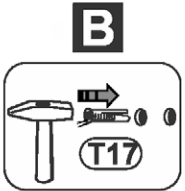
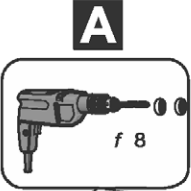
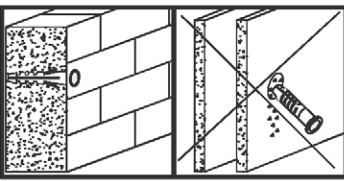
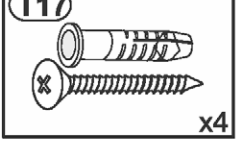
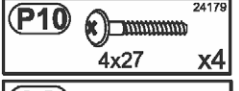
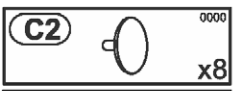
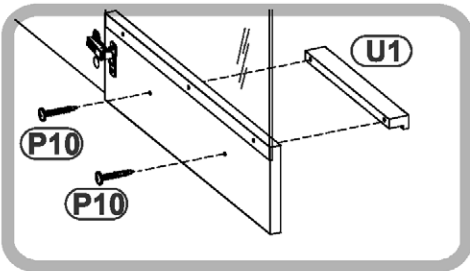

LKZ 80152

Modellname/Modelname/Nomdumodele/Modellnamn
 Nomemodello/Názvemodelu/Modelnaam/Imemodella
 NuméroModello/Modellineve/ Названиemodeli /
 Názovmodelu/Imemodella/Denumiremodel/
 Наименованиemodela /Nazwamodelu

TTX07

Modellnummer/Number/Numérodumodele
 Numero/ Номернамодела/modello
 Císlumodelu/Modellszáma/Eíslumodelu
 Števílkamodela/ Numãmodel /Brojmodela
 Modelnummer/Numermodelu

1563-001-01

Type/Тipo/Тípus/Тур/Тип /Tip

001

D Unser Direktservice für Beschlagteile
 Sollte Ihnen ein Beschlagteil fehlen, können Sie diese Servicekarte direkt an die untenstehende Adresse mailen. Wir können allerdings nur Beschlagteile auf diesem Wege verschicken. Sollten Sie eine andere Beanstandung an Ihrem Möbelstück haben, so wenden sie sich bitte direkt an Ihr Möbelhaus.

GB Our direct order service for fitting
 If a fitting part is missing, you can e-mail this service card directly to the address below. However, we can only send fitting parts in this way. If you have any other cause for complaint concerning your item of furniture, please contact your furniture store directly.

CZ Naše přímé služby pro kování
 Chybí-li vám nějaký díl z kování, můžete tuto servisní kartu odeslat e-mailem přímo na níže uvedenou adresu. Touto cestou však můžeme zoslat jen díly kování. Pokud byste reklamovali jiný díl nábytku, obraťte se přímo na svého prodejce nábytku.

F Bien étudier la notice de montage
 S'il vous manque une ferrure, veuillez envoyer directement la présente carte service à l'adresse e-mail indiquée ci-dessous. Cependant, ceci nous permet uniquement d'envoyer des ferrures. Pour tout autre type de réclamation concernant votre meuble, veuillez contacter directement votre magasin d'ameublement.

I Il nostro servizio diretto per l'ordine della ferramenta
 Qualora Vi dovesse mancare un pezzo di fissaggio, allora Vi preghiamo di inviare questa carta di servizio immediatamente all'indirizzo sottostante. Possiamo inviare i pezzi di fissaggio solamente per mezzo di questo procedimento. Qualora dovete avere qualche altra reclamazione in merito al mobile, allora Vi preghiamo di rivolgerVi direttamente al Vostro Negozio di mobili.

BG Нашата директна услуга за обкова
 Ако липсват части от комплекта, потърнете настоящата сервисна карта и ни я изпратете на e-mail адреса, посочен по-долу. По този начин можем да доставяме само липсващи елементи от обкова. Ако установите други дефекти по мебелите, Ви съветваме да се обърнете към мебелната къща/магазин, от който сте закупили стоката.

NL Onze directservice voor losse onderdelen
 Wanneer er een onderdeel ontbreekt, kunt u deze servicekaart direct aan onderstaand e-mailadres sturen. Wij kunnen langs deze weg echter alleen beslagdelen versturen. Mocht u een ander probleem aan uw meubel hebben, verzoeken wij u contact op te nemen met uw meubeldealer.

PL Nasz bezpośredni serwis części montażowych
 Jeżeli brakuje części koniecznych do montażu, prosimy o przesłanie nam niniejszej karty serwisowej na niżej podany adres e-mailowy. W ten sposób możemy przelać Państwu tylko brakujące części. W przypadku innych reklamacji dotyczących mebla, prosimy zgłosić się do salonu meblowego, w którym został dokonany zakup.

HR Servis za okove
 U slučaju da nedostaje neki od dijelova molimo vas da na dolje navedenu mail adresu pošaljete ovaj servisni obrazac. Na ovaj način mogu se dostaviti samo okovi. U slučaju da imate dodatne prigovore vezane uz komad namještaja molimo vas da se obratite izravno trgovini namještaja gdje je isti kupljen.

HU Direktszolgálatunk vasalatók esetén
 Ha hiányzik egy vasalát, ezt a kártyát közvetlenül elküldheti az alább található címre. Azonban csak vasalatókat tudunk így küldeni. Amennyiben másfajta reklamációt áll fenn bútorárbaját illetően, forduljon közvetlenül a bútorárhöz.

SK Naš priamy servis pre časti kovania
 Ak by Vám chýbala nejaká časť kovania, môžete poslať túto servisnú kartu poslať e-mailom na nižšie uvedenú adresu. Diely kovania vieme poslať iba týmto spôsobom. Ak by ste mali inú reklamáciu ohľadom Vášho nábytku, obráťte sa priamo na Vašu predajňu nábytku.

SLO Naše direktne uslužne storitve za okovje
 Če vam manjka kakšno okovje, lahko to servisno kartico pošljete po e-pošti direktno na spodnji naslov. Po tej poti vam lahko pošljemo samo okovje. Če želite reklamirati kakšen drug del pohištva, se obrnite neposredno na vašo trgovino pohištva.

RO Service-ul nostru direct pentru feronerie
 În cazul în care vă lipsește o piesă de feronerie puteți să trimiteți direct card de service prin e-mail la adresa de mai jos. Noi nu putem expedia piese de feronerie decât pe această cale. Dacă aveți o altă reclamație referitoare la piesa de mobilier, atunci vă rugăm să vă adresați direct la magazinul dvs. de mobilă.

RUS Наш прямой сервис для поставок фурнитуры
 Если окажется, что Вам не хватает того или иного элемента фурнитуры, Вы можете отправить сервисную карту по факсу непосредственно на нижеприведенный адрес электронной почты. Однако, таким образом мы можем пересылать лишь фурнитуру. Если же у Вас возникнут иные претензии относительно приобретенной мебели, пожалуйста, обращайтесь непосредственно в организацию, осуществляющую продажу.

S Vår direktservice för beslagdelar
 Om du saknar en beslagdel kan du skicka detta servicekort direkt till e-postadressen som anges nedan. Tänk på att detta är den enda möjligheten att skicka beslagdelar till dig. Om du vill reklamera din möbel av en annan anledning måste du kontakta ditt möbelhus direkt.

ES Nuestro servicio directo para accesorios
 Si le falta algún accesorio, puede enviar esta tarjeta de servicio directamente a la siguiente dirección. No obstante, por este método solo podemos enviar accesorios. Si tiene alguna otra objeción sobre su mueble, consulte directamente con su mueblería.

TR Donatılar için doğrudan servisimiz
 Bir donatınız eksikse bu servis kartını doğrudan aşağıda bulunan adrese doğrudan mail yazabilirsiniz. Sadece bu yolla donatılar gönderiliriz. Mobilyanızda başka şikayetleriniz varsa lütfen doğrudan mobilya satıcınıza danışın.

max.

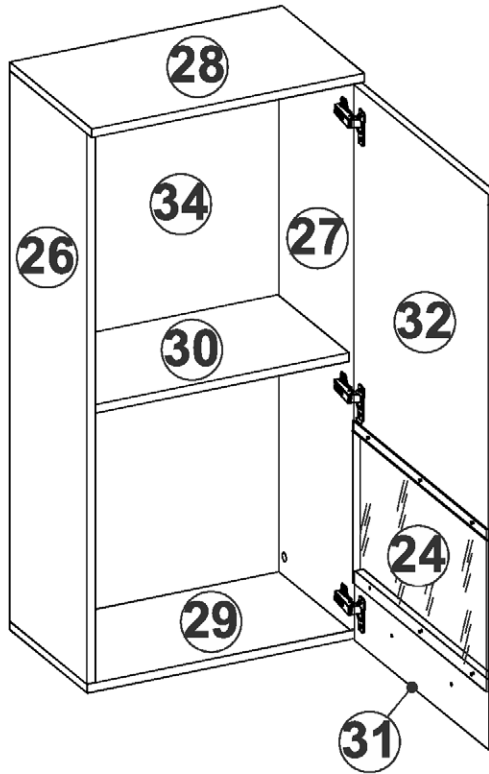

Colli 1

Colli 2

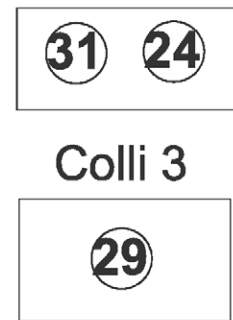
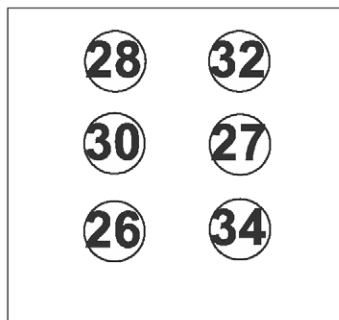

28	7014352
32	7014356
30	7014355
27	7014353
26	7014354
31	7014357
24	3006083
29	7014351
34	7014358

Gründer/Beanstandung/Reasonoftheobjection:

Möbelhaus/Furniturestore:

Name/Nom: Telefon/Telephone:

PLZ/Banksortingcode: Ort/City:

Strasse/Street:

Haus-Nr./HouseNo.: @E-Mail:

LKZ 80152

Modellname/Modelname/Nomdumodele/Modellnamn
Nomemodello/Názevmodelu/Modelnaam/Imemodela
NúmeroModello/Modellneve/ Названиемодели /
Názovmodelu/Imemodela/Denumiremodel/
Наименованиемодела /Nazwaodelu

TTX07

Modellnummer/Number/Numérodumodele
Numero/ Номернамодела/modello
Číslomodelu/Modellszáma/Elsiomodelu
Številkamodela/ Numärmodel /Brojmodela
Modelnummer/Numemodellu

1563-001-01 

Type/Тipo/Тípus/Тур/Тип /Tip

001

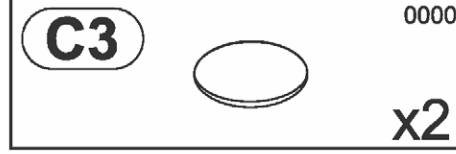
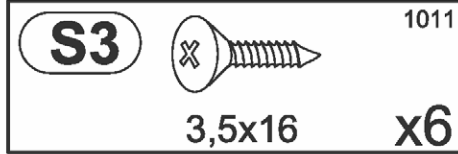
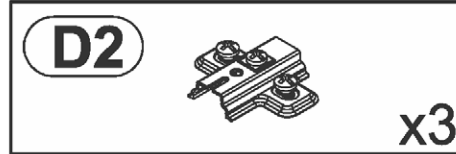
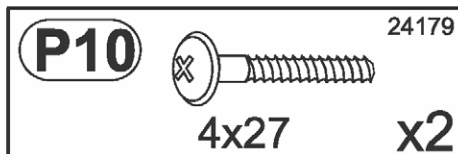
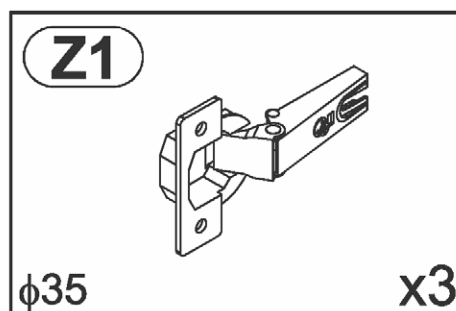
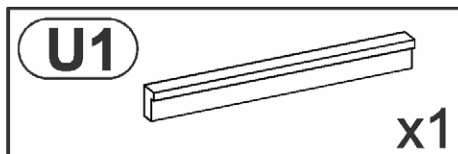
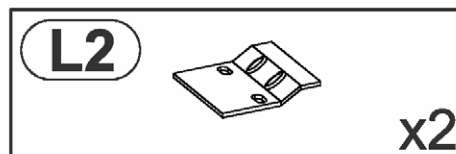
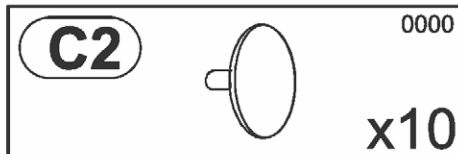
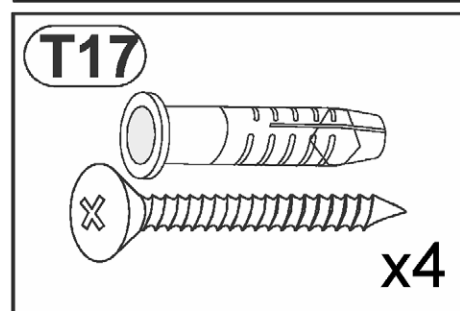
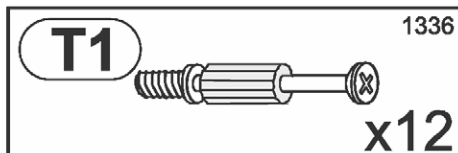
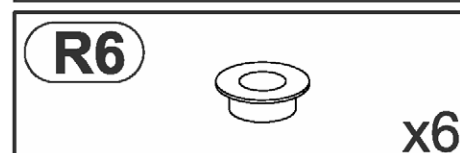
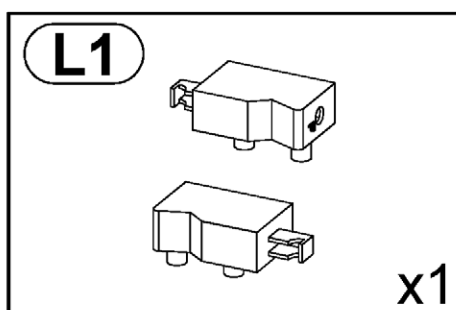
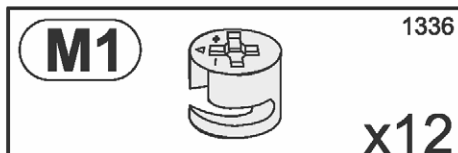
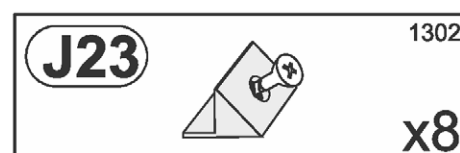
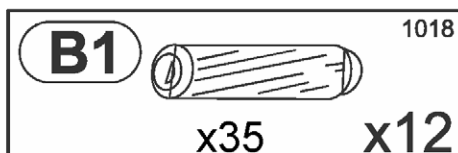

1

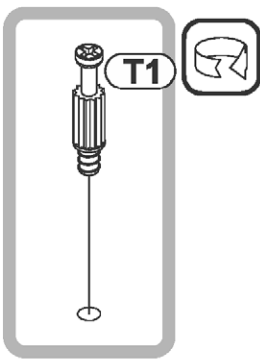
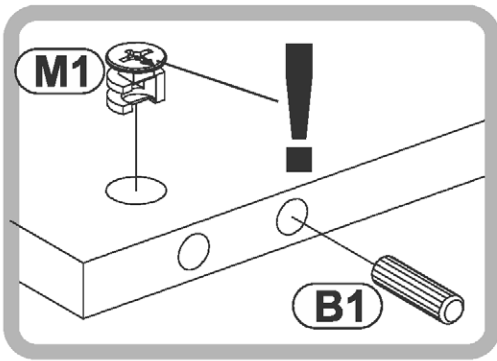

(B1) 1018
8x35 x12

(M1) 1336
x12

(T1) 1336
x12

(P7)
4x30 x4

(L1)
x1

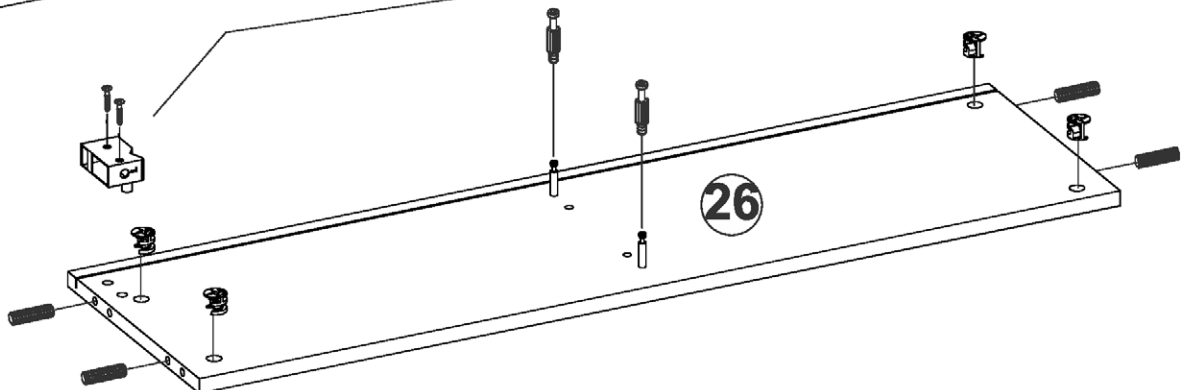
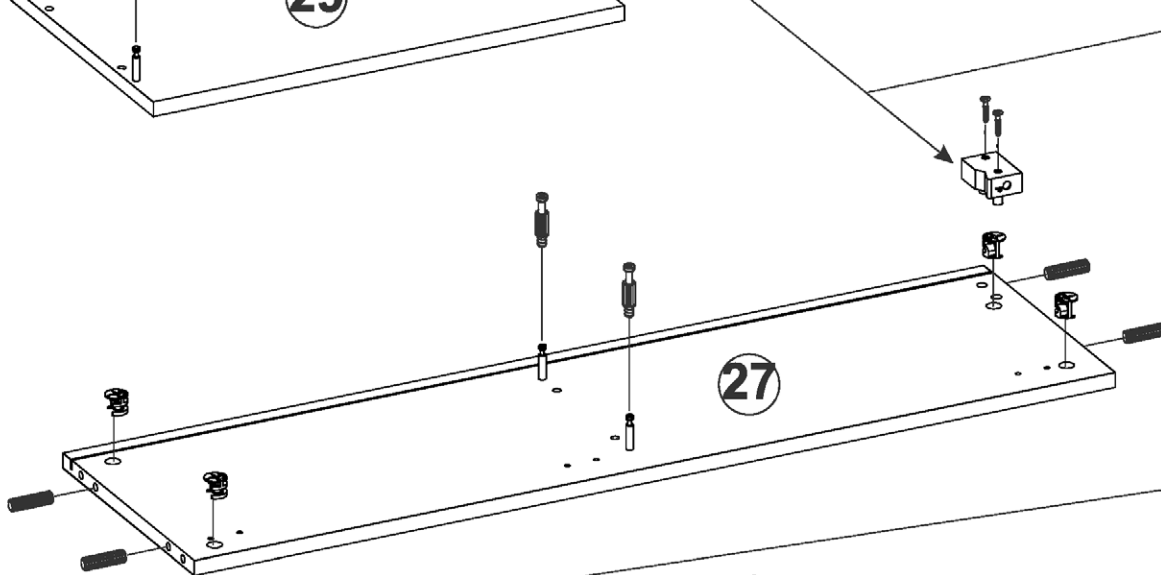
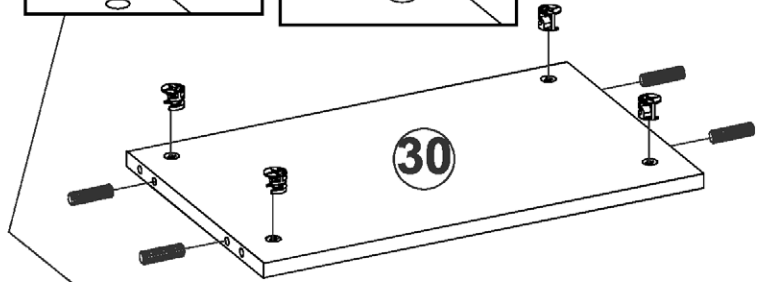
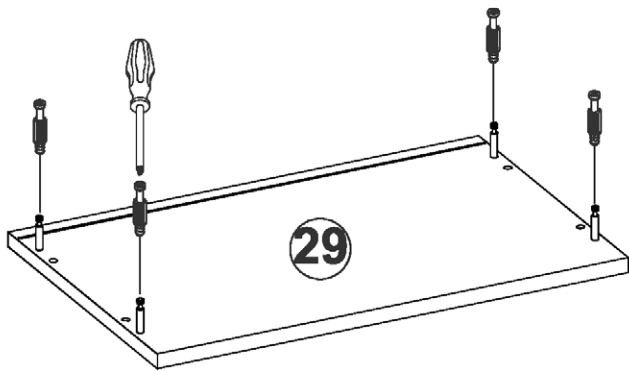
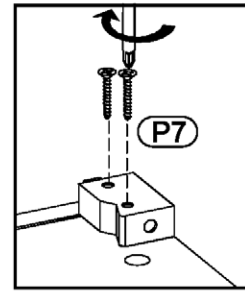
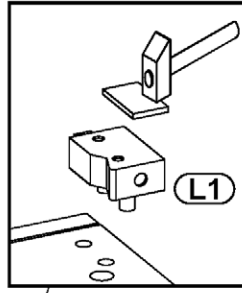
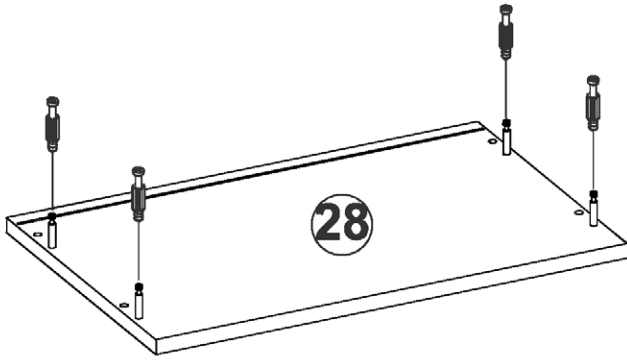
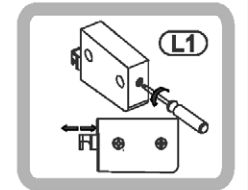

3

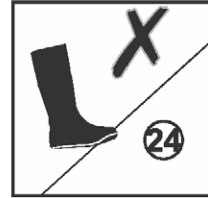
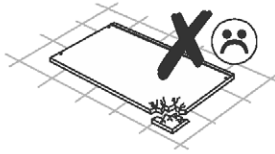
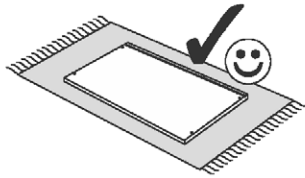

- P6** 4x16 x6
- R6** x6
- S3** 3,5x16 x6 ¹⁰¹¹
- Z1** ϕ 35 x3

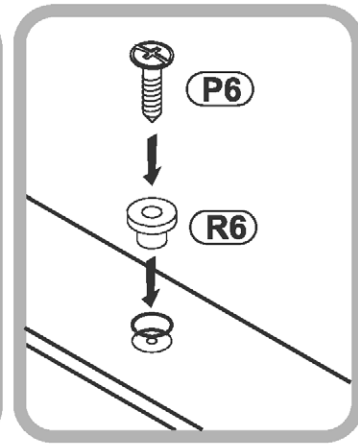
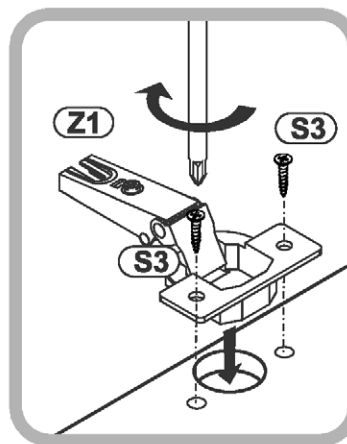
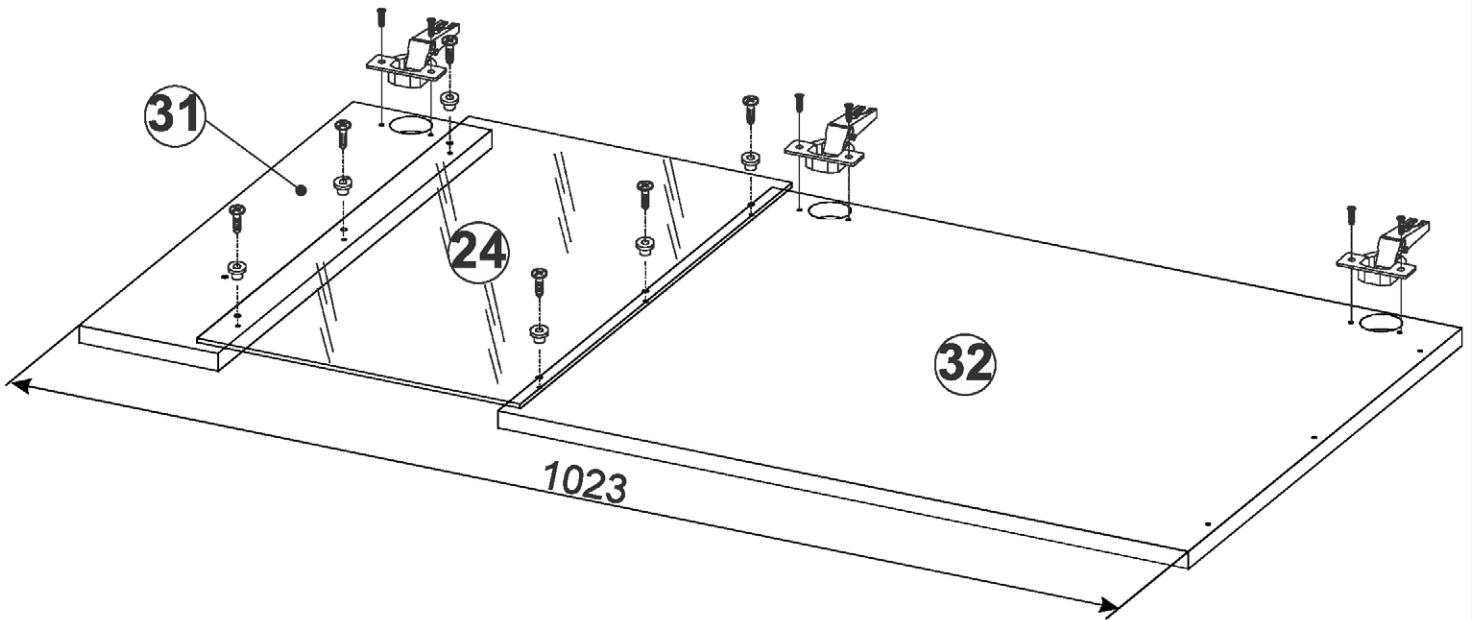

4

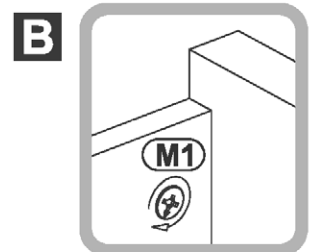
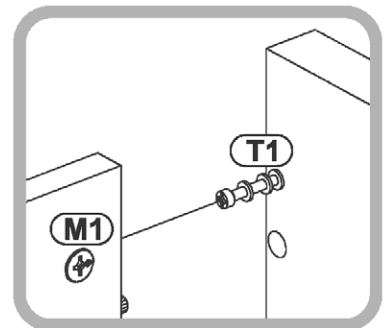
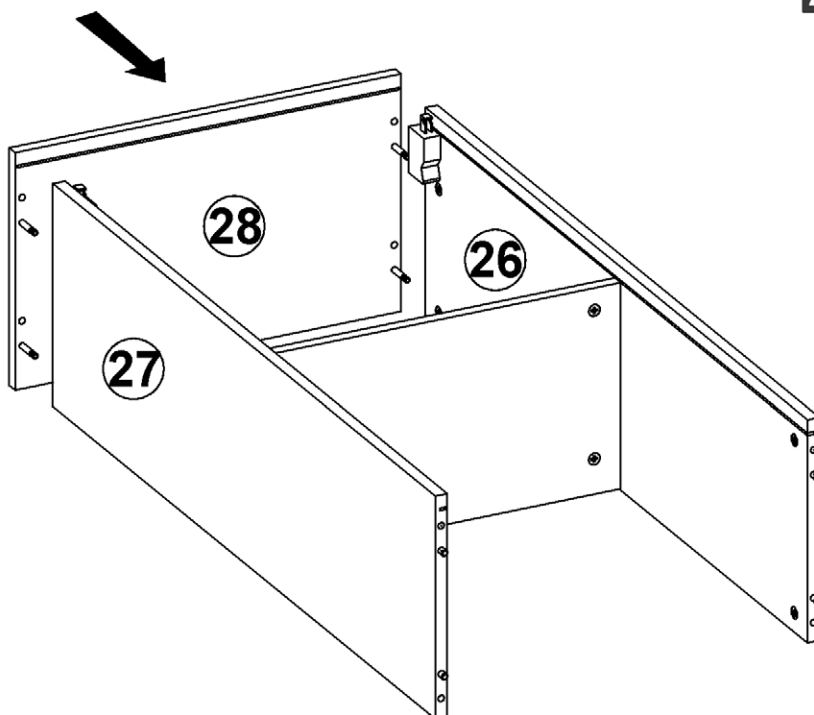
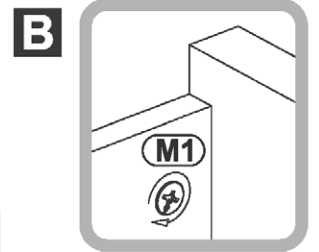
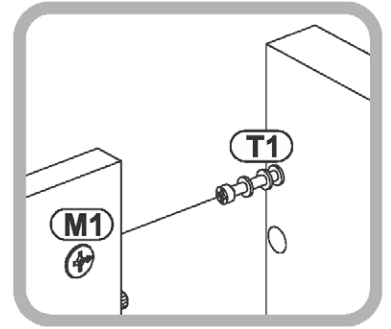
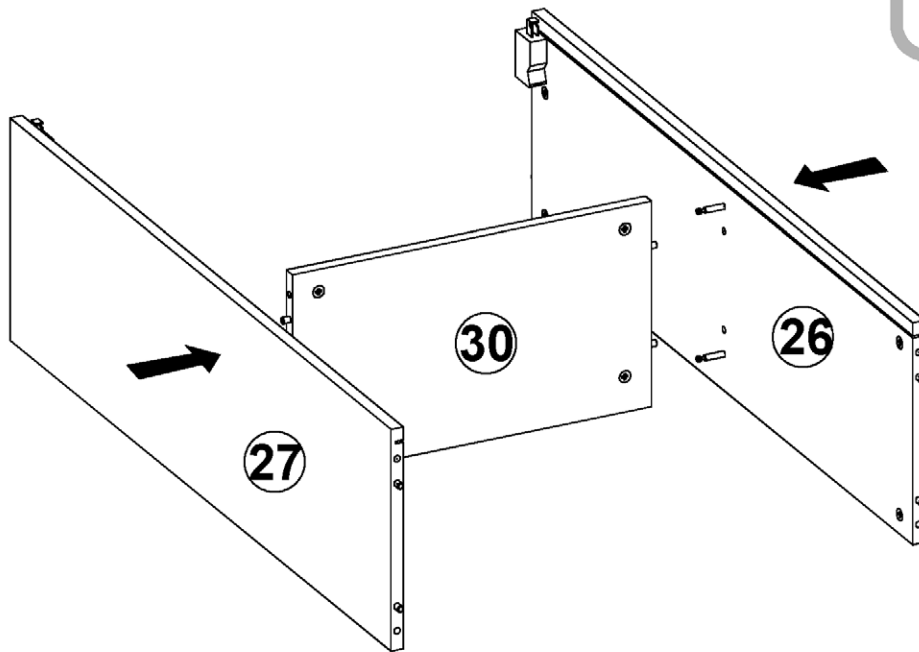

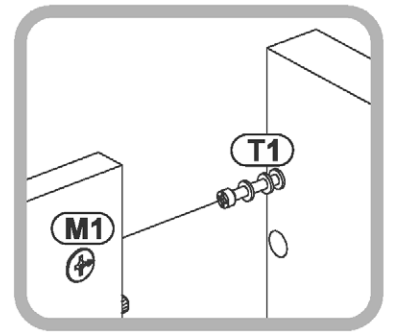
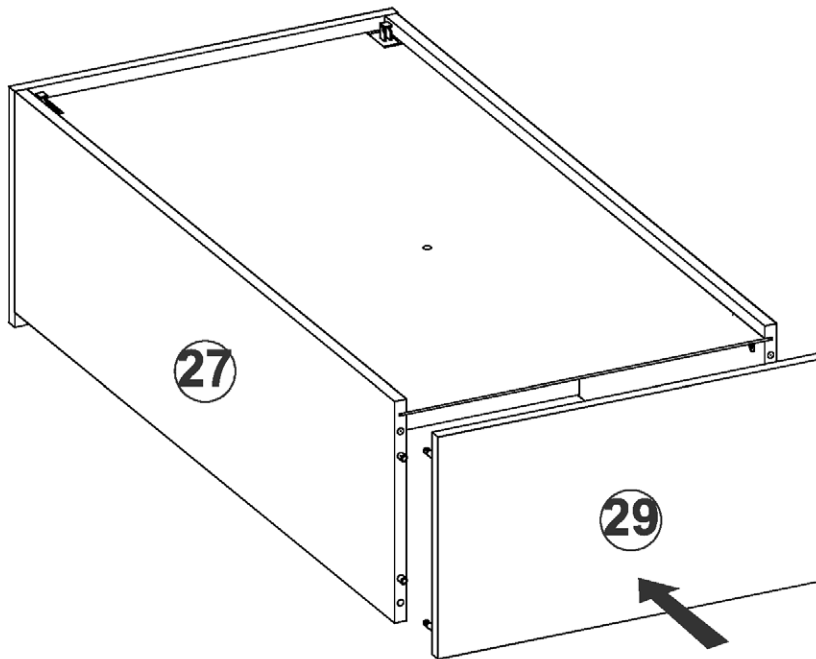
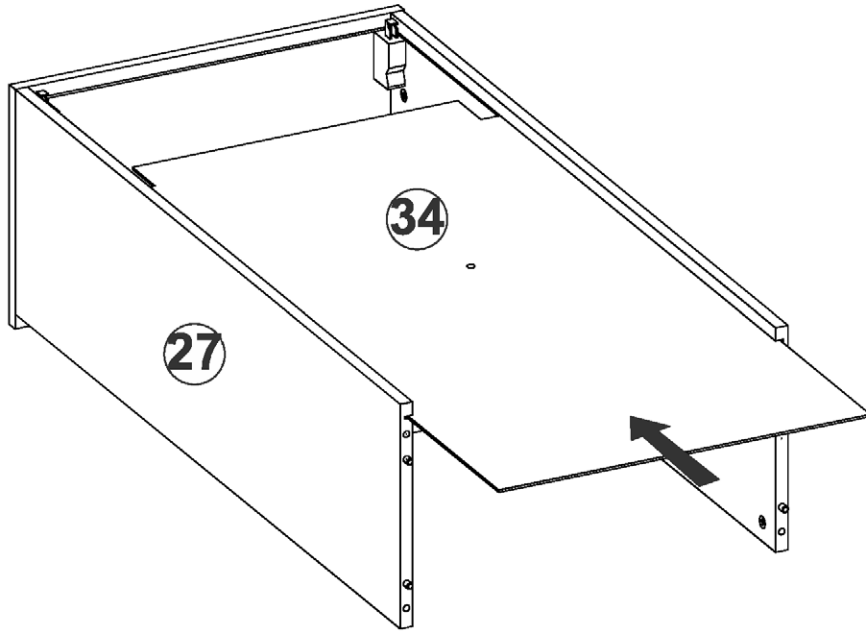

5

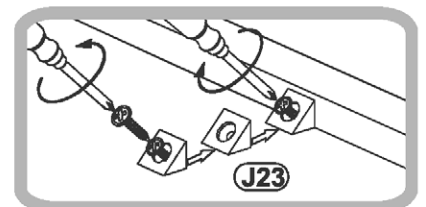
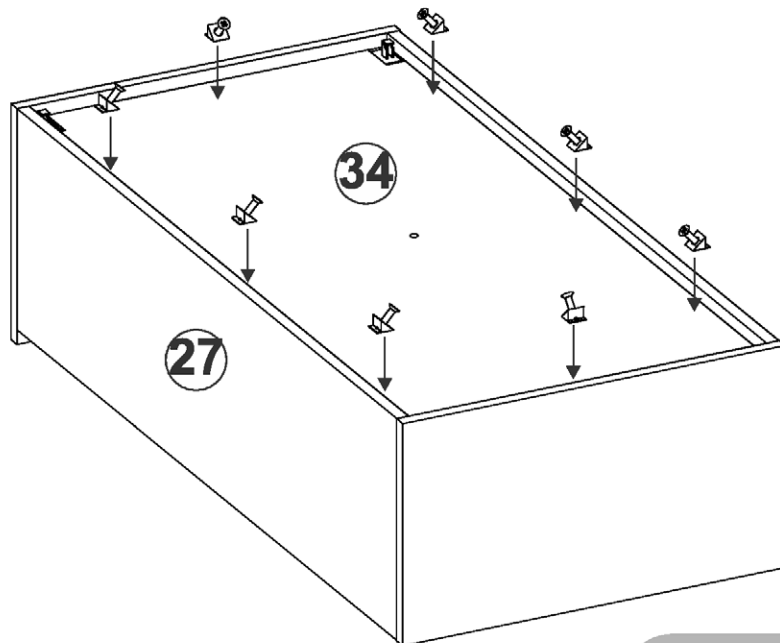
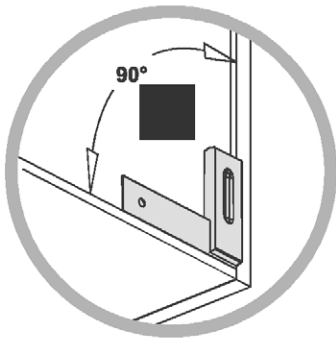
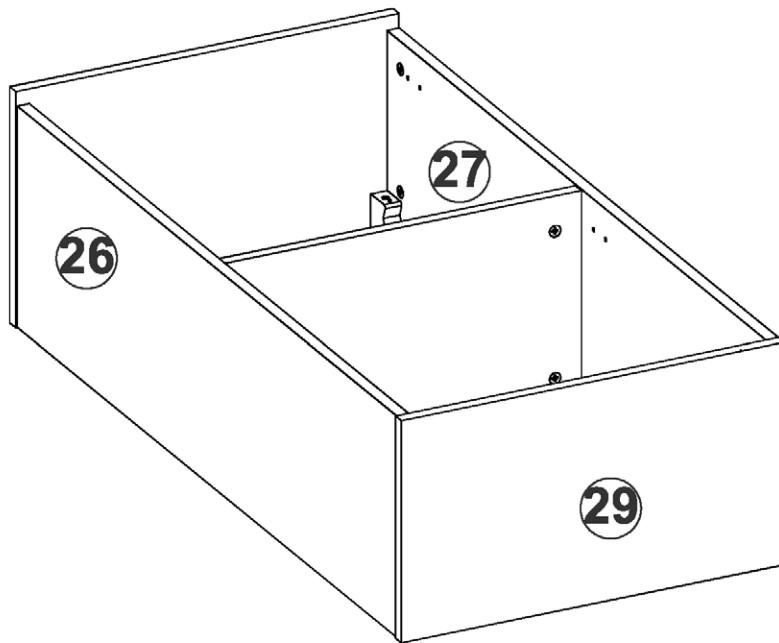
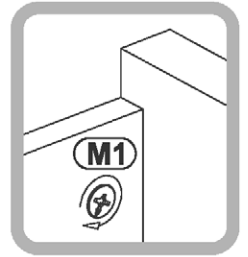

6



7

D2		x3
C3		0000 x2

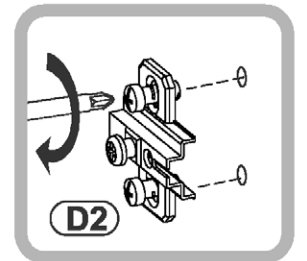
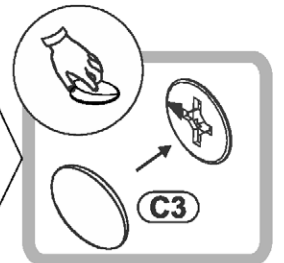
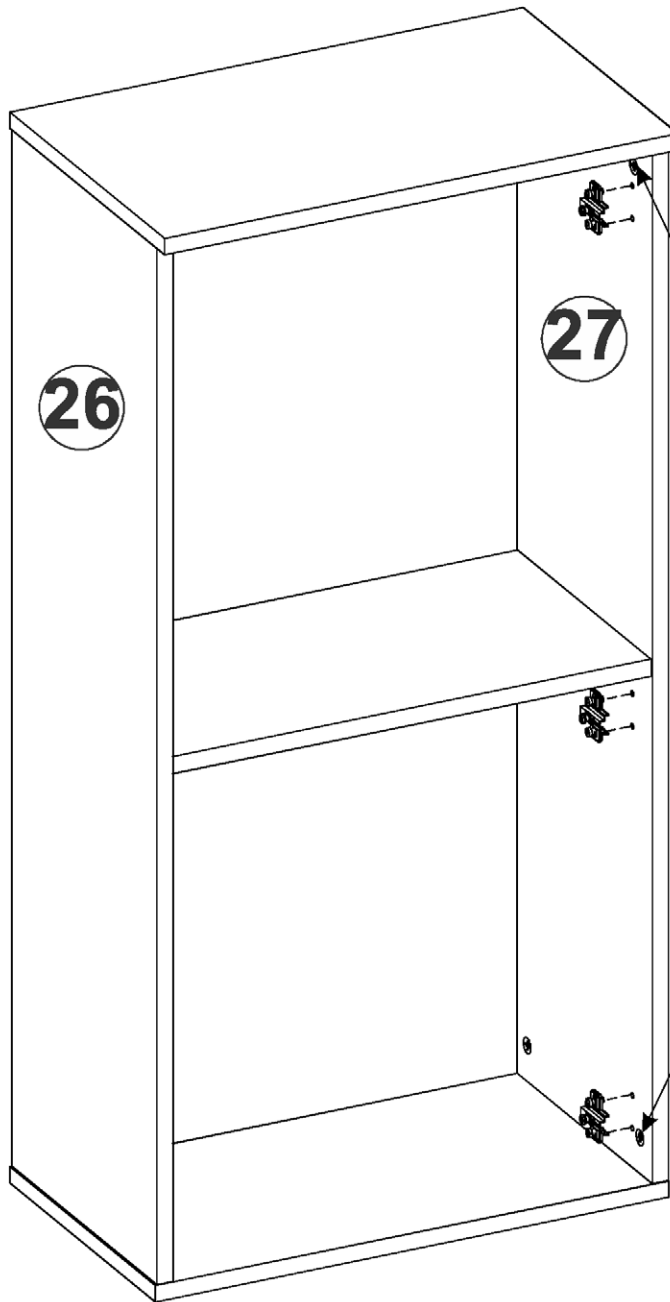

1.

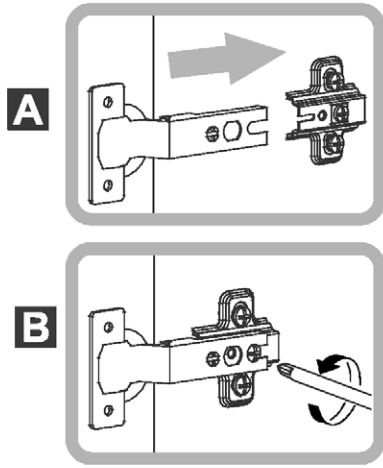

2.

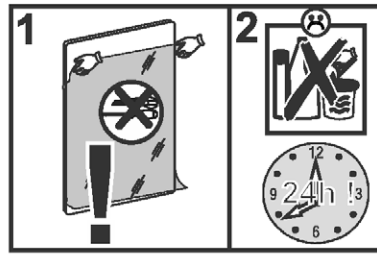

3.

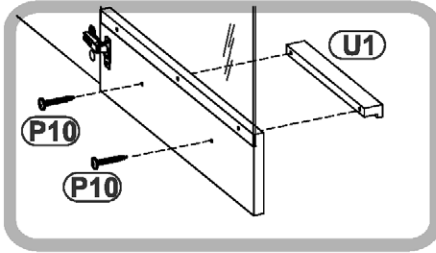

- C2** x10
- U1** x1
- P10** 4x27 x2
- L2** x2
- T17** x4

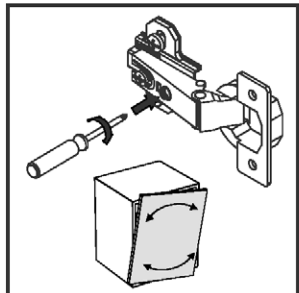
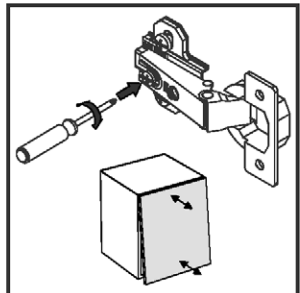
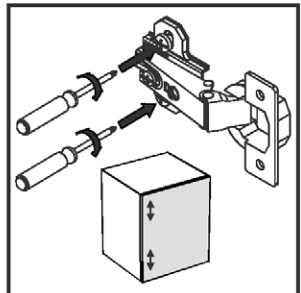
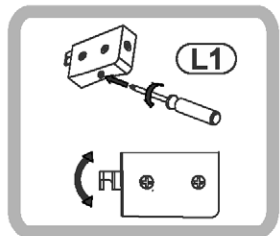
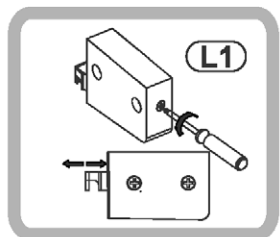
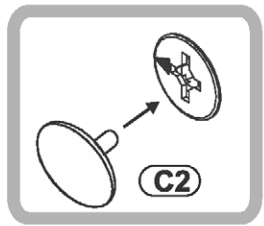
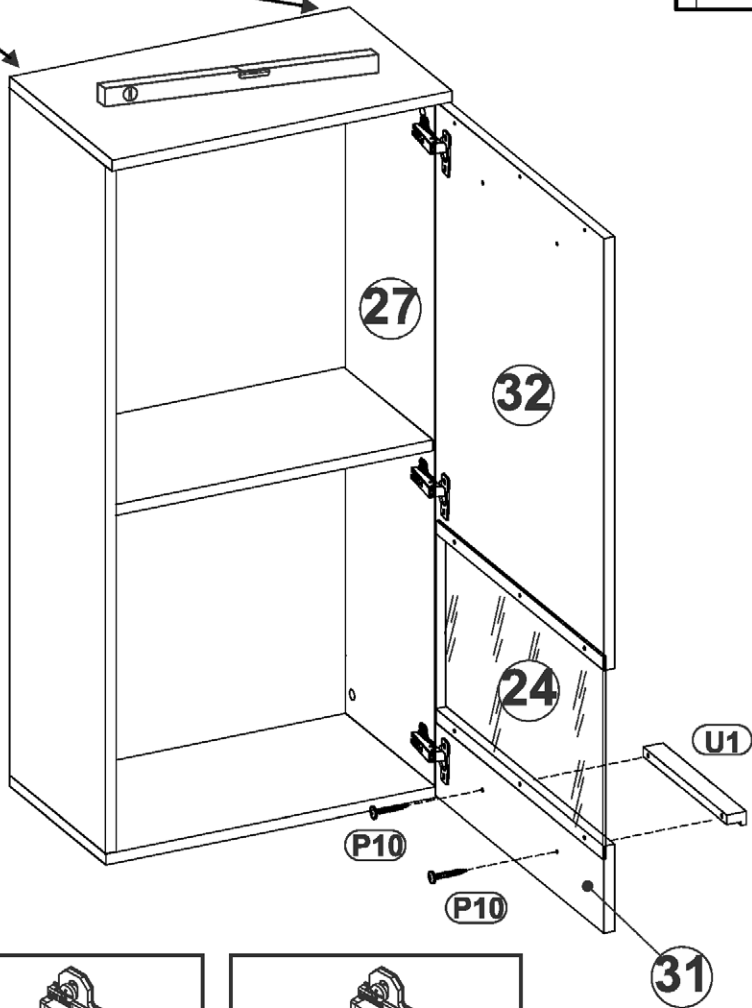
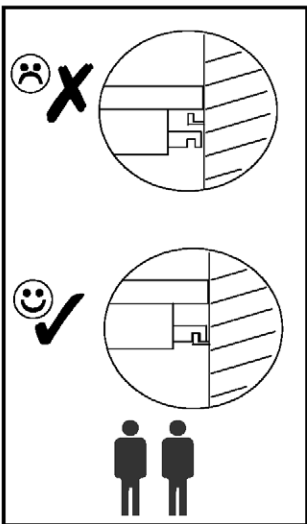
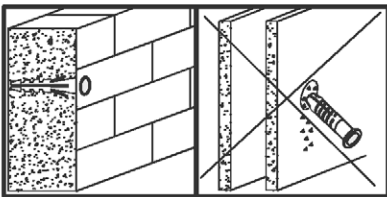
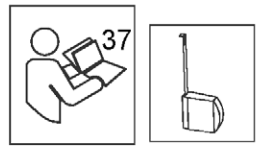
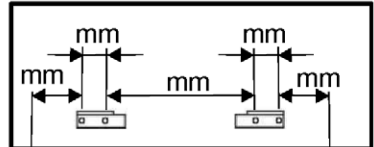
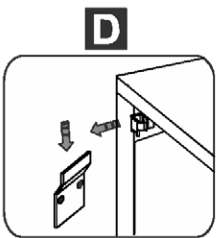
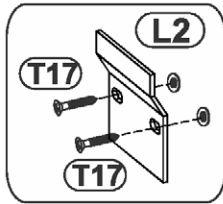
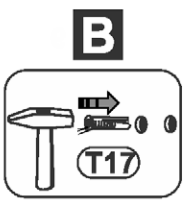
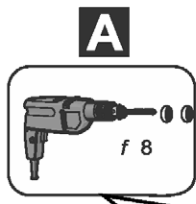

9

