

SKIN

Geben Sie hier den Modellnamen ein

1116-031-02

1116-031-42

Geben Sie hier die Modellnummer ein

031

Geben Sie hier den Typ ein

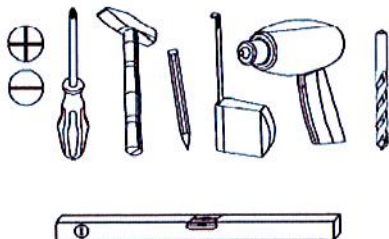
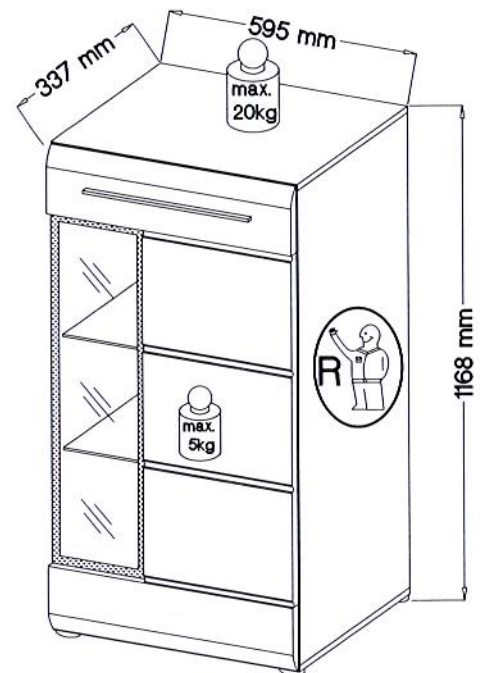
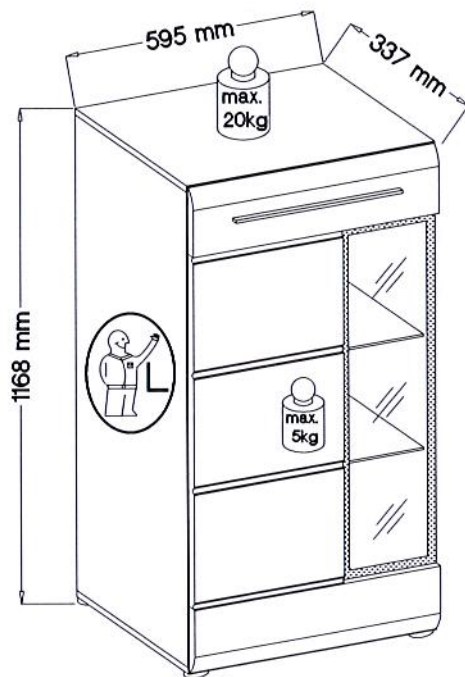
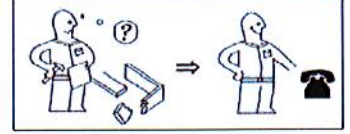

festziehen / tighten / Затягивать / seret / stringere / utahnut / vastrekken / zatightnut / atárgere / związac / zadanao szorosan / moghúzni / pevno došahnut / trdno pritegniti / zatygnut / dia št / hjar / Skin



eindrücken / press in / enfoncer / wolsnac / nbattre / zatlačit / Bvapakre / indrukken / benyomni / stlačit / vstisni / bruck in / introduce / prin apăsare / vdativ / empujar / İçeri bastırın



ausmessen / measure / măsurar / măsurare / opmēten / izmeriti / mīlara / kimēriti / izmeriti / măsurare / izmerit / zmērit / Vmēpote / māt upp / zmierzyc / medir / Ölçün



drücken / press / presser / stisknut / Haviverte / vstisni / nasinac / drukken / pritisnuti / naosnac / pritisni / nakatu / megnyomni / apăsare / tryck fast / načsnač / presionar / Bastırın



einschlagen / hammer in / beverni / sla in / frapper au marteau / infossare / Zabit / zaražit / Hačivite / zabiti / wbici / introduce prin batiere / zabiti / zabit / clavar / İçeri vurun



Drehen - wonden / przekreć - odwrócić / Keren - omdraalen / Girare - Rotare / Okrnuti - uturiti / Retourner - renverser / Turn over - turn around / Oboče - obratiti / Zauvpreta - obkupi-are / Oboče list / Inbatič / tobit / Vrki runt - vänd / nrokvritn - rospivite / oboč - obrati / estorgatiri - megfordiani / Giar / Çevirin

SKIN

Geben Sie hier den Modellnamen ein

1116-031-02
1116-031-42

Geben Sie hier die Modellnummer ein

031

Geben Sie hier den Typ ein

D Unser Direktservice für Beschädigte
Sollte Ihnen ein Beschädigter fehlen, können Sie diese Servicekarte direkt an die untenstehende Adresse mailen. Wir können allerdings nur Beschädigte auf diesem Wege verschicken. Sollten Sie eine andere Beanstandung an Ihrem Möbelstück haben, so wenden Sie sich bitte direkt an Ihr Möbelhaus.

GB Our direct order service for fitting
If a fitting part is missing, you can e-mail this service card directly to the address below. However, we can only send fitting parts in this way. If you have any other cause for complaint concerning your item of furniture, please contact your furniture store directly.

CZ Naše přímé služby pro kování
Chybí-li vám nějaký díl z kování, můžete tuto servisní kartu odeslat e-mailem přímo na níže uvedenou adresu. Touto cestou však můžeme zrealizovat jen díly kování. Pokud byste reklamovali jiný díl nábytku, obraťte se přímo na svého prodejce nábytku.

F Bien étudier la notice de montage
Si il vous manque une ferrure, veuillez envoyer directement la présente carte service à l'adresse e-mail indiquée ci-dessous. Cependant, ceci nous permet uniquement d'envoyer des ferrures. Pour tout autre type de réclamation concernant votre meuble, veuillez contacter directement votre magasin d'ameublement.

I Il nostro servizio diretto per l'ordine della ferramenta
Qualora Vi dovesse mancare un pezzo di fissaggio, allora Vi preghiamo di inviare questa carta di servizio immediatamente all'indirizzo sottostante. Possiamo inviare i pezzi di fissaggio solamente per mezzo di questo procedimento. Qualora dovreste avere qualche altra reclamazione in merito al mobile, allora Vi preghiamo di rivolgerVi direttamente al Vostro Negoziò di mobili.

BG Нашата директна услуга за обков
Ако липсват части от комплекта, потърнете настоящата сервисна карта и ни я изпратете на e-mail адреса, посочен по-долу. По този начин можем да доставим само липсващи елементи от обкова. Ако установите други дефекти по мебелите, Ви съветваме да се обвържете към мебелната къща/магазин, от който сте закупили стоката.

NL Onze directservice voor losse onderdelen
Wanneer er een onderdeel ontbreekt, kunt u deze servicekaart direct aan onderstaand e-mailadres sturen. Wij kunnen langs deze weg echter alleen beschadigden herstellen. Mocht u een ander probleem aan uw meubel hebben, verzoeken wij u contact op te nemen met uw meubeldealer.

PL Nasz bezpośredni serwis części montażowych
Jeżeli brakuje części koniecznych do montażu, prosimy o przesłanie nam niniejszej karty serwisowej na niżej podany adres e-mailowy. W ten sposób możemy przesyłać Państwu tylko brakujące części. W przypadku innych reklamacji dotyczących mebla, prosimy zgłosić się do salonu meblowego, w którym został dokonany zakup.

HR Servis za okove
U slučaju da nedostaje neki od dijelova molimo vas da na dole navedenu mail adresu pošaljete ovaj servisni obrazac. Na ovaj način mogu se dostaviti samo okovi. U slučaju da imate dodatne prigovore vezane uz komad namještaja molimo vas da se obratite izravno trgovini namještaja gdje je isti kupljen.

HU Direktszolgálatunk vasalatok esetén
Ha hiányzik egy vasalat, ezt a kártyát közvetlenül elküldheti az alább taláható címre. Azonban csak vasalatok tudunk így küldeni. Amennyiben másfajta reklamáció áll fenn bútorrészaját illetően, forduljon közvetlenül a bútorházhöz.

SK Naš priamy servis pre čisti kovánie
Ak by Vám chýbala nejaká časť kování, môžete poslať túto servisnú kartu priamo na nižšie uvedenú adresu. Diely kování vieme poslať iba týmto spôsobom. Ak by ste mali inú reklamáciu ohľadom Vašho nábytku, obraťte sa priamo na Vašu predajňu nábytku.

SLO Naše direktne uslužne storitve za kovina
Če vam manjka kakšno okovje, lahko to servisno kartico pošljete po e-pošti direktno na spodnji naslov. Po tej poti vam lahko pošljemo samo okovje. Če imate reklamacijo kakšen drug del pohištva, se obrnite neposredno na vaše trgovino pohištva.

RO Service-ul nostru direct pentru feronerie
În cazul în care vă lipsește o piesă de feronerie puteți să trimiteți direct acest card de service prin e-mail la adresa de mai jos. Noi nu putem expedia piese de feronerie decât pe acest mod. Dacă aveți o altă reclamație referitoare la piesa de mobilier, atunci vă rugăm să vă adresați direct la magazinul dvs. de mobilier.

RUS Наш прямой сервис для поставок фурнитуры
Если окажется, что Вам не хватает того или иного элемента фурнитуры, Вы можете отправить сервисную карту по факсу непосредственно на нижеприведенный адрес электронной почты. Однако, таким образом мы можем пересылать лишь фурнитуру. Если же у Вас возникнут иные претензии относительно приобретенной мебели, пожалуйста, обращайтесь непосредственно в организацию, осуществляющую продажу.

S Vår direktservice för beslagdelar
Om du saknar en beslagdel kan du skicka detta servicekort direkt till e-postadressen som anges nedan. Tank på att detta är den enda möjligheten att skicka beslagdelar till dig. Om du vill reklamera din möbel av en annan anledning måste du kontakta ditt möbelhus direkt.

ES Nuestro servicio directo para accesorios
Si le falta algún accesorio, puede enviar esta tarjeta de servicio directamente a la siguiente dirección. No obstante, por este método solo podemos enviar accesorios. Si tiene alguna otra objeción sobre su mueble, consulte directamente con su mueblería.

TR Donatılar için doğrudan servisimiz
Bir donatınız eksikse bu servis kartını doğrudan aşağıda bulunan adrese doğrudan mail yazabilirsiniz. Sadece bu yolla donatılar gönderilebilir. Mobilyanızda başka şikayetleriniz varsa lütfen doğrudan mobilya satıcınıza danışın.

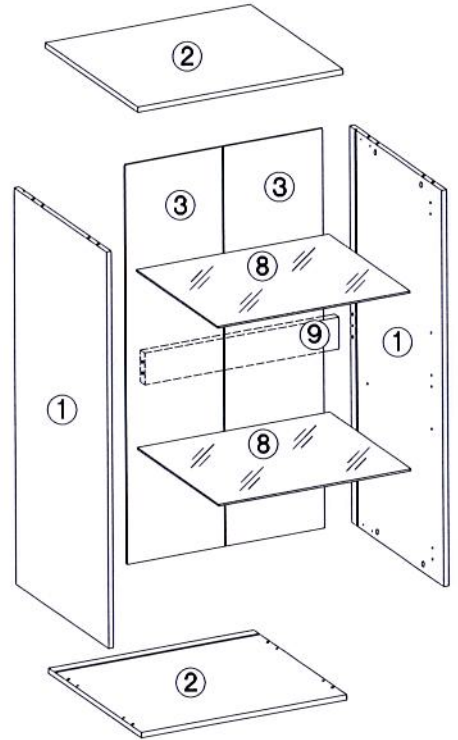
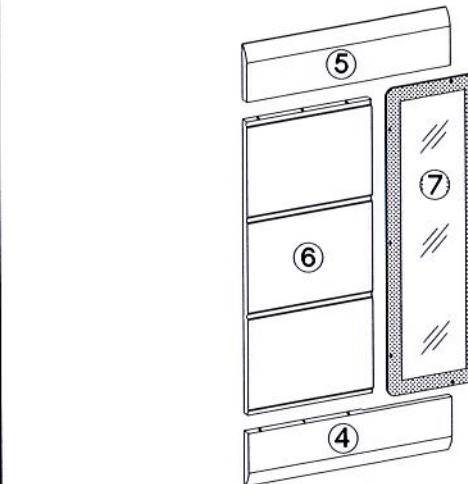
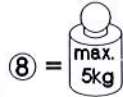

3B :			
	6	3	3

2B :							4B :	
	2	2	4	2	1	2		1

1B :								
	3	1	1	1	4	4	1	5
1B :								
	10	10	10	8	8	8	3	5

LKZ 80106

Grund der Beanstandung / Reason of the objection: _____

Möbelhaus / Furniture store: _____

Name / Name: _____ Telefon / Telephone: _____

PLZ / postal code: _____ Ort / City: _____

Strasse / Street: _____

Haus-Nr. / House No.: _____ @E-Mail: _____

SKIN

Geben Sie hier den Modellnamen ein

1116-031-02
1116-031-42

Geben Sie hier die Modellnummer ein

031

Geben Sie hier den Typ ein

D Unser Direktservice für Beschädigte
Sollte Ihnen ein Beschädigter fehlen, können Sie diese Servicekarte direkt an die untenstehende Adresse mailen. Wir können allerdings nur Beschädigte auf diesem Wege verschicken. Sollten Sie eine andere Beanstandung an Ihrem Möbelstück haben, so wenden Sie sich bitte direkt an Ihr Möbelhaus.

GB Our direct order service for fitting
If a fitting part is missing, you can e-mail this service card directly to the address below. However, we can only send fitting parts in this way. If you have any other cause for complaint concerning your item of furniture, please contact your furniture store directly.

CZ Naše přímé služby pro kování
Chybí-li vám nějaký díl z kování, můžete tuto servisní kartu odeslat e-mailem přímo na níže uvedenou adresu. Touto cestou však můžeme zrealizovat jen díly kování. Pokud byste reklamovali jiný díl nábytku, obraťte se přímo na svého prodejce nábytku.

F Rien à signaler la notice de montage
Si à votre montage une ferrure, veuillez envoyer directement la présente carte service à l'adresse e-mail indiquée ci-dessous. Cependant, ceci nous permet uniquement d'envoyer des ferrures. Pour tout autre type de réclamation concernant votre meuble, veuillez contacter directement votre magasin d'ameublement.

I Il nostro servizio diretto per l'ordine della ferramenta
Qualora Vi dovesse mancare un pezzo di fissaggio, allora Vi preghiamo di inviare questa carta di servizio immediatamente all'indirizzo sottostante. Possiamo inviare i pezzi di fissaggio solamente per mezzo di questo procedimento. Qualora dovesse avere qualche altra reclamazione in merito al mobile, allora Vi preghiamo di rivolgerVi direttamente al Vostro Negoziò di mobili.

BG Нашата директна услуга за обик
Ако липсва част от комплекта, попълнете настоящата сервисна карта и ни я изпратете на e-mail адреса, посочен по-долу. По този начин можем да доставим само липсващи елементи от обик. Ако установите други дефекти по мебелите, Ви съветваме да се обръщате към мебелната къща/магазин, от който сте закупили стоката.

NL Onze directservice voor losse onderdelen
Wanneer er een onderdeel ontbreekt, kunt u deze servicekaart direct aan onderstaand e-mailadres sturen. Wij kunnen langs deze weg echter alleen beschadigde verstuuren. Mocht u een ander probleem aan uw meubel hebben, verzoeken wij u contact op te nemen met uw meubeldealer.

PL Nasz bezpośredni serwis części montażowych
Jeżeli brakuje części koniecznych do montażu, prosimy o przesłanie nam niniejszej karty serwisowej na niżej podany adres e-mailowy. W ten sposób możemy przesyłać Państwu tylko brakujące części. W przypadku innych reklamacji dotyczących mebla, prosimy zgłosić się do salonu meblowego, w którym został dokonany zakup.

HR Servis za okove
U slučaju da nedostaje neki od dijelova molimo vas da na dole navedenu mail adresu pošaljete ovaj servisni obrazac. Na ovaj način mogu se dostaviti samo okovi. U slučaju da imate dodatne prigovore vezane uz komad namještaja molimo vas da se obratite izravno trgovini namještaja gdje je isti kupljen.

HU Direktszolgálatunk vasalatok esetén
Ha hiányzik egy vasalat, ezt a kártyát közvetlenül elküldheti az alább található címre. Azonban csak vasalatokhoz tudunk így küldeni. Amennyiben másfajta reklamáció áll fenn bútoráruházi illetlen, forduljon közvetlenül a boltvezetőhöz.

SK Naše priame služby pre častí kovania
Ak by Vám chýbala nejaká časť kovania, môžete poslať túto servisnú kartu poslať e-mailom na nižšie uvedenú adresu. Diely kovania vieme poslať iba týmto spôsobom. Ak by ste mali inú reklamáciu ohľadom Vášho nábytku, obraťte sa priamo na Vašu predajňu nábytku.

SLO Naše direktne uslužbne storitve za okovje
Če vam manjka kakšno okovje, lahko to servisno kartico pošljete po e-pošti direktno na spodnji naslov. Po tej poti vam lahko pošljemo samo okovje. Če imate reklamacijo kakšnega drugega pohištva, se obrnite neposredno na vašo trgovino pohištva.

RO Serviciu-ul nostru direct pentru feronerie
In cazul in care va lipseste o piesa de feronerie puteti sa trimiti direct acest card de service prin e-mail la adresa de mai jos. Noi nu putem expedia piese de feronerie decat pe aceasta cale. Daca aveti o alta reclamatie referitoare la piesa de mobilier, atunci va rugam sa va adresati direct la magazinul dvs. de mobilier.

RUS Наш прямой сервис для поставок фурнитуры
Если ожидается, что Вам не хватает того или иного элемента фурнитуры, Вы можете отправить сервисную карту по факсу непосредственно на нижеприведенный адрес электронной почты. Однако, таким образом мы можем пересылать лишь фурнитуру. Если же у Вас возникнут иные претензии относительно приобретенной мебели, пожалуйста, обращайтесь непосредственно в организацию, осуществляющую продажу.

S Vår direktservice för beslagsdelar
Om du saknar en beslagsdel kan du skicka detta servicekort direkt till e-postadressen som anges nedan. Tänk på att detta är den enda möjligheten att skicka beslagsdelar till dig. Om du vill reklamera din möbel av en annan anledning måste du kontakta ditt möbelhus direkt.

ES Nuestro servicio directo para accesorios
Si le falta algún accesorio, puede enviar esta tarjeta de servicio directamente a la siguiente dirección. No obstante, por este método solo podemos enviar accesorios. Si tiene alguna otra objeción sobre su mueble, consulte directamente con su mueblería.

TR Donatlar için doğrudan servisimiz
Bir donatınız eksikse bu servis kartını doğrudan aşağıda bulunan adrese doğrudan mail yazabilirsiniz. Sadece bu yolla donatıları gönderebiliriz. Mobilyanızda başka şikayetleriniz varsa lütfen doğrudan mobilya satıcınıza danışın.

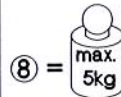

⑧ = max. 5kg



③5x13mm		③5/0mm
P5	H	G
6	3	3



③5/10mm	L=20mm	③8x60mm	0,05	③7/2mm	L=404 mm
C4	D2	A2	E1	O11	J5
2	2	4	2	1	2
					④B: S1
					1



③4.0x27mm	③3.5x13mm	③10x50mm	③4.0x25mm	L=③18mm	③7/4mm
R1	P5	O7	L9	P14	F10
3	1	1	1	4	4
③8x30mm	L=20mm	③5/12mm		③5	③4.0x16mm
A	D2	C	E	L	J23
10	10	10	8	8	8
					3
					5

LKZ 80106

Grund der Beanstandung / Reason of the objection:

Möbelhaus / Furniture store:

Name / Name: _____ Telefon / Telephone: _____

PLZ / postal code: _____ Ort / City: _____

Strasse / Street: _____

Haus-Nr. / House No.: _____ @E-Mail: _____



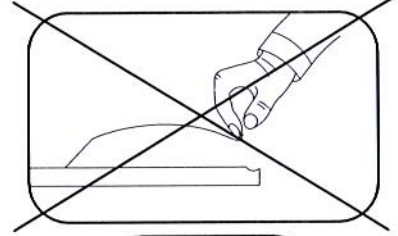
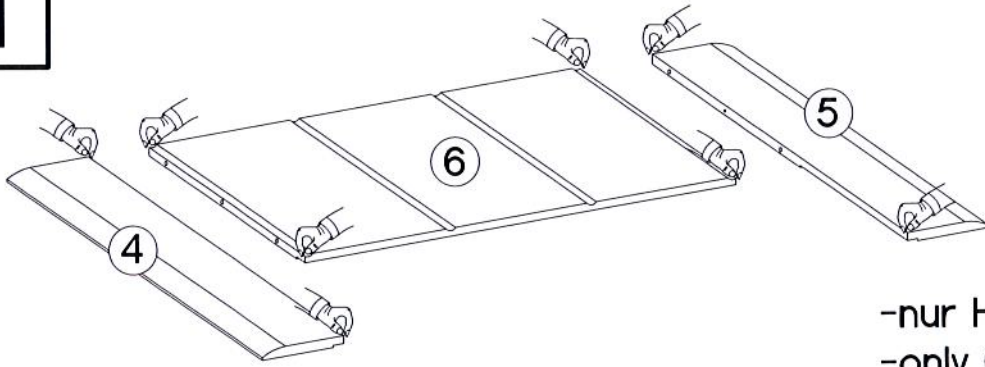

1

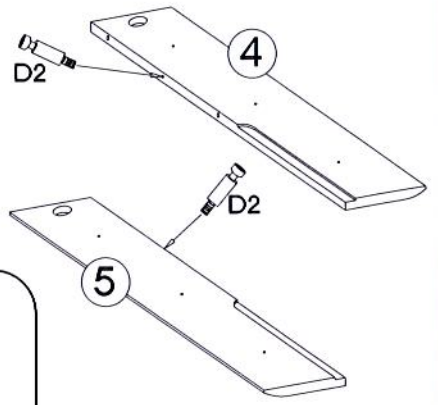
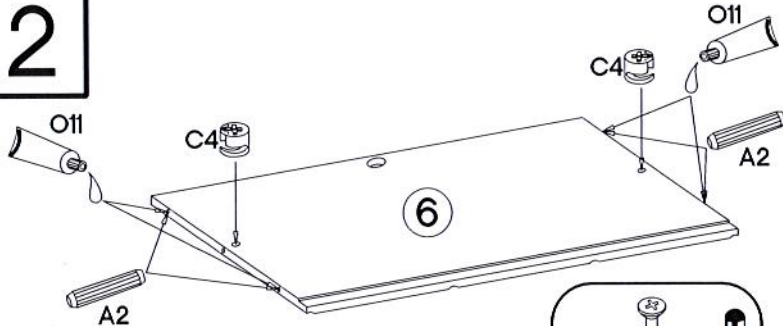

-nur HG
-only GLOS

2



 +8x60mm A2 4	 L=20mm D2 2	 +5/10mm C4 2	 0,05 O11 1
---	---	--	--

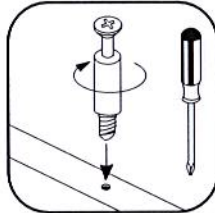

3

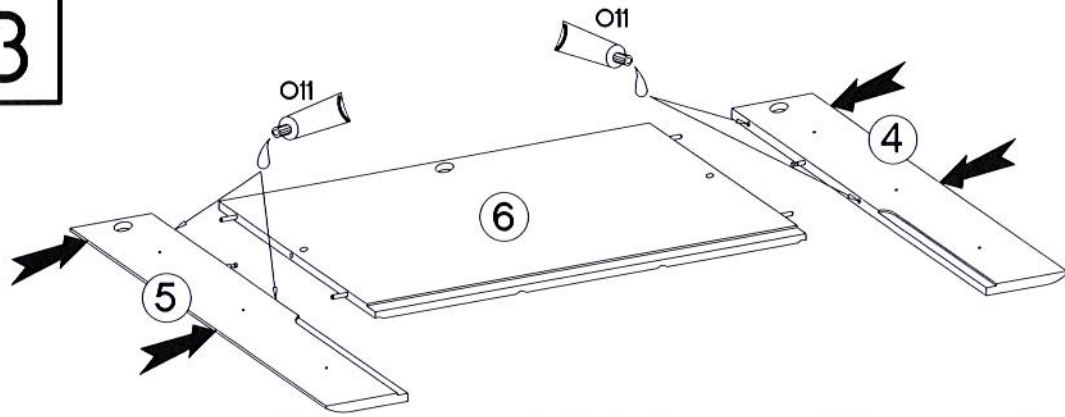



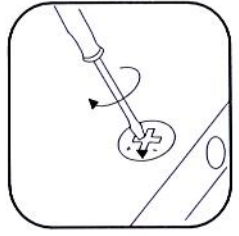

 0,05 O11 1

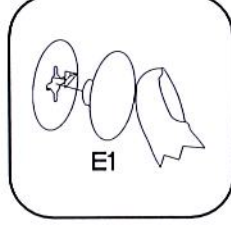
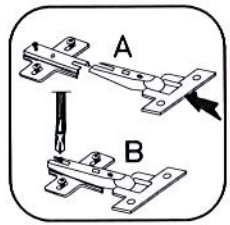

4



 +7/2mm J5 2	 +3.5x13mm E1 2	 +3.5x13mm P5 6	 +35/0mm H 3	 +35/0mm G 3
--	---	---	--	--

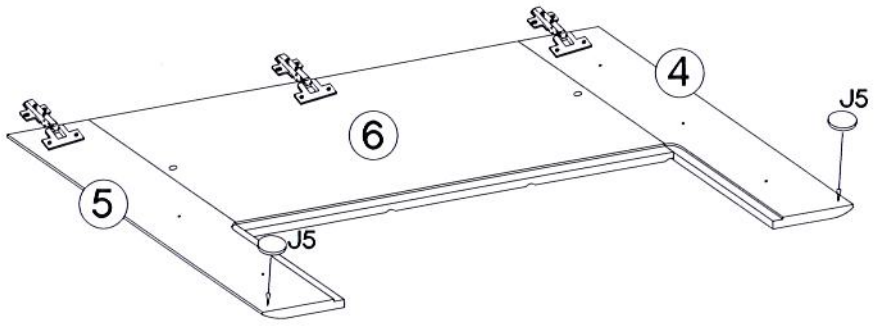
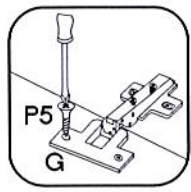

5

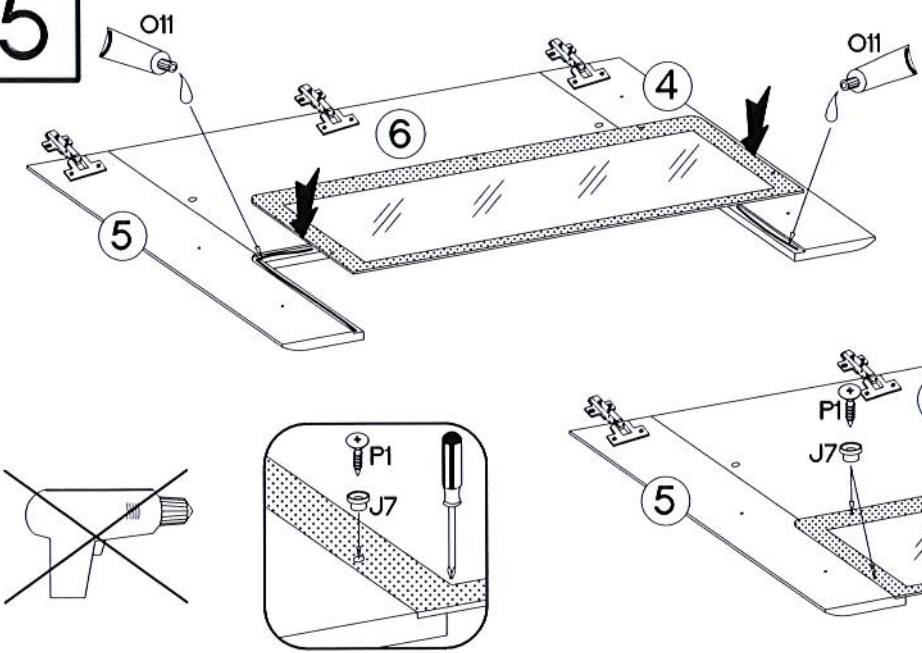

±7/4mm J7	0,05 Oll
5	1
±4.0x16mm P1	
5	

6

±8x30mm A	L=20mm D2	±5/12mm C	±4.0x25mm P14	F10
10	10	10	4	4

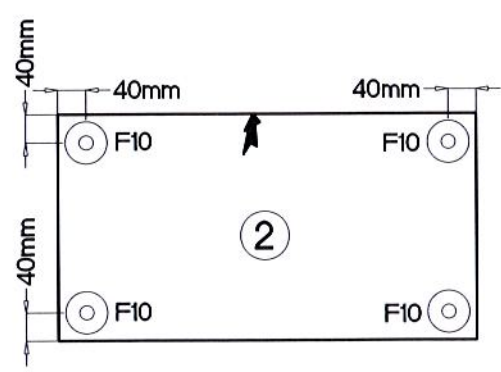
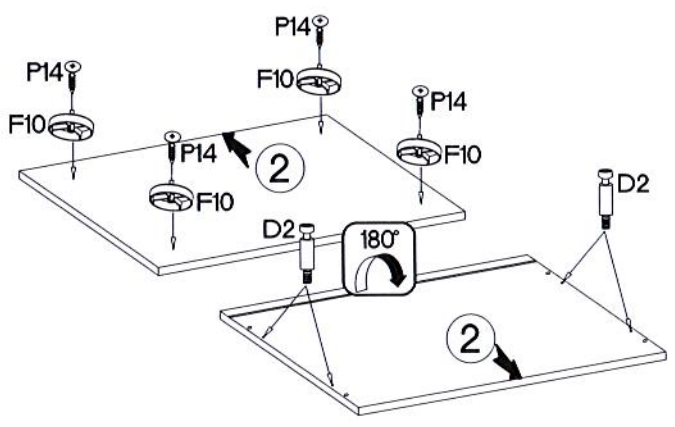
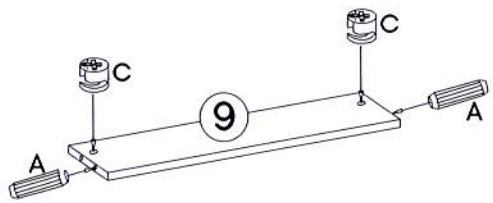
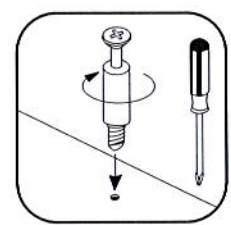
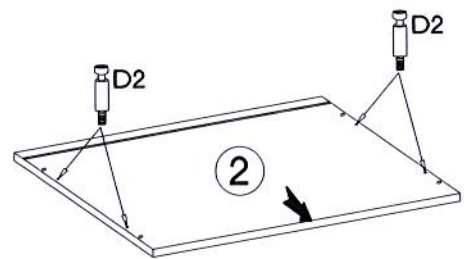
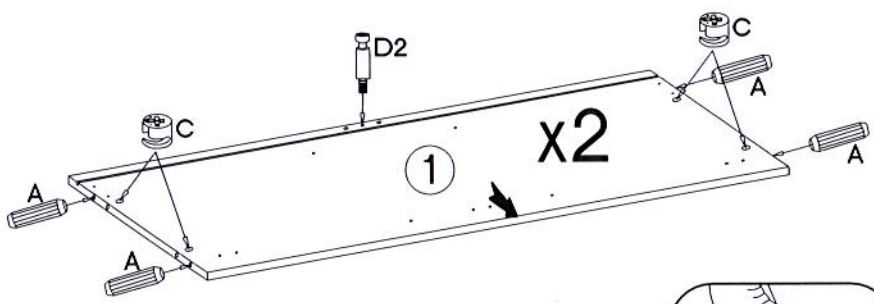

7

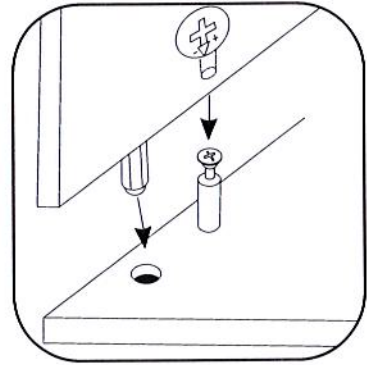
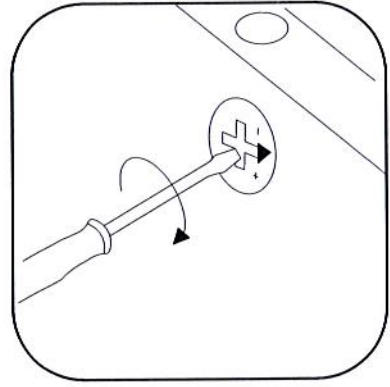
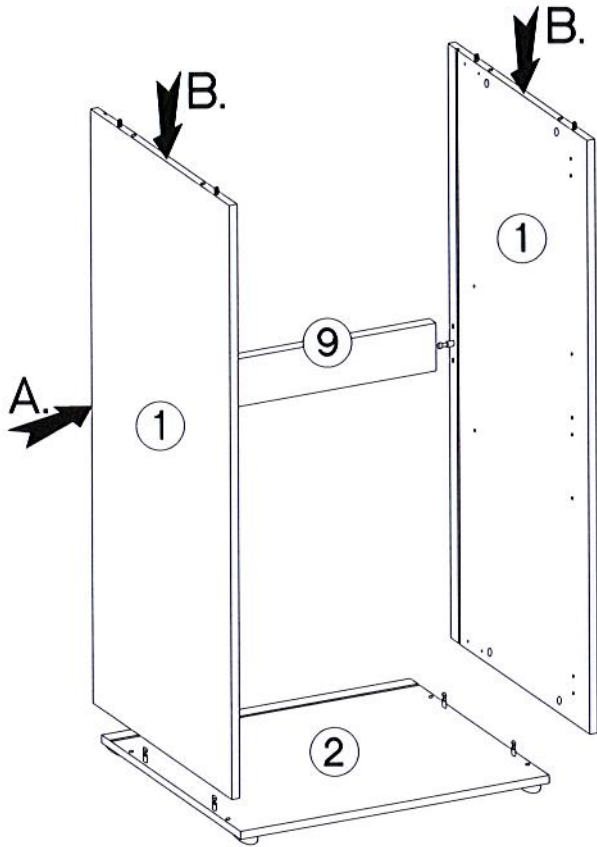

8

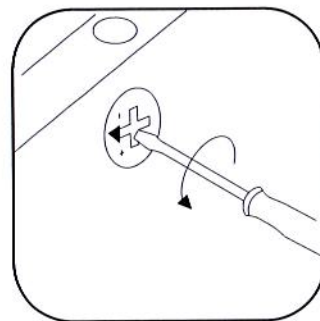
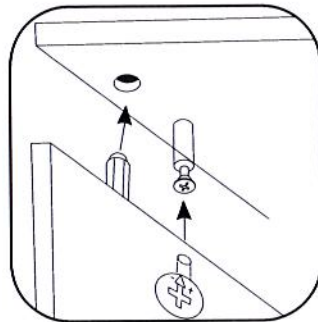
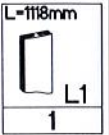
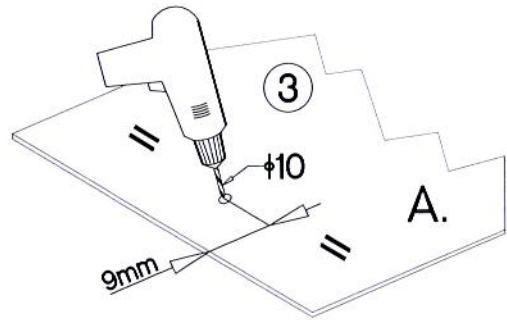
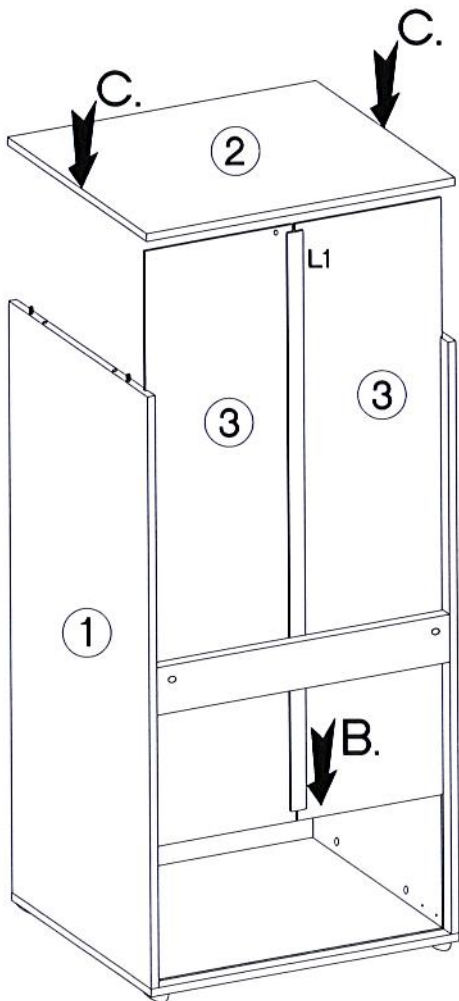

9

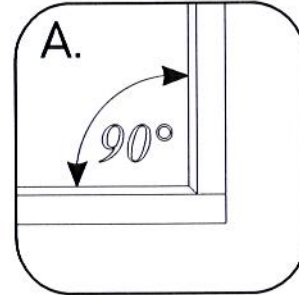
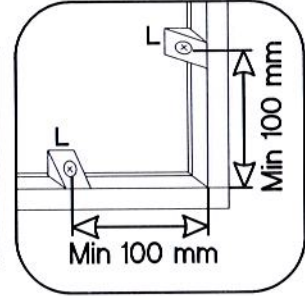
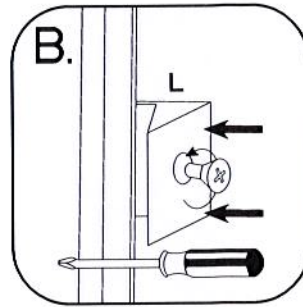
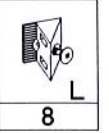
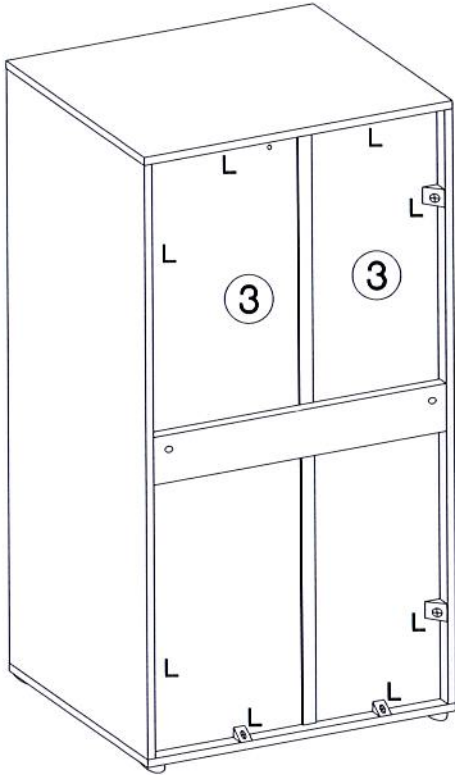

10

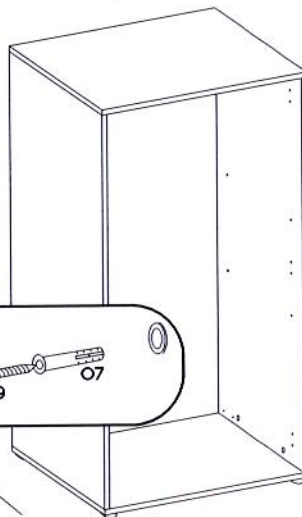
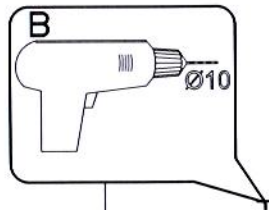
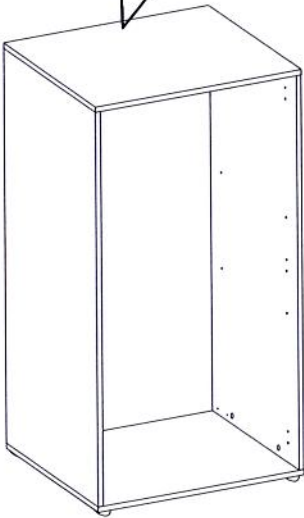
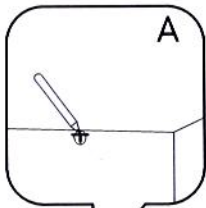

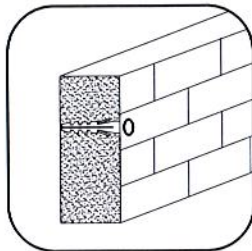
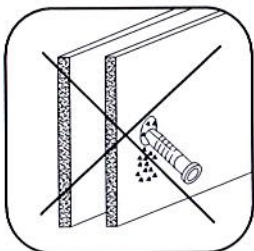
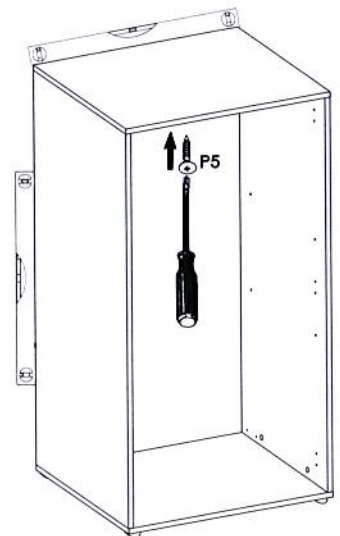
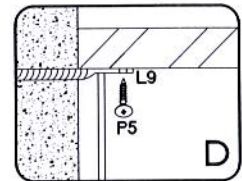

 P5 1	 O7 1	 L9 1
-------------	-------------	-------------

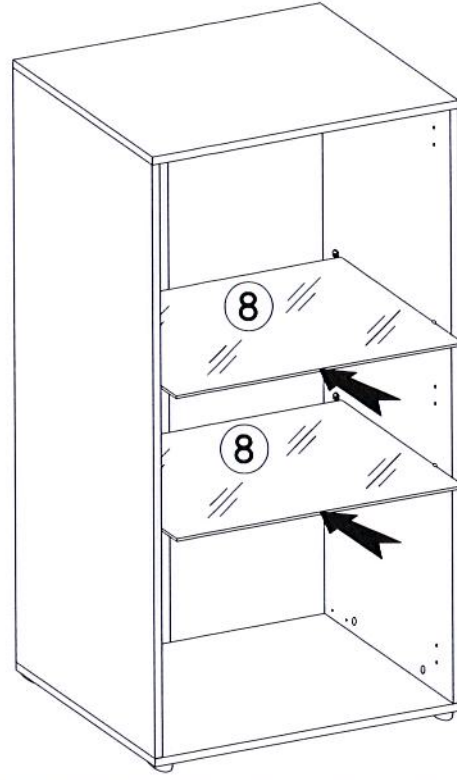
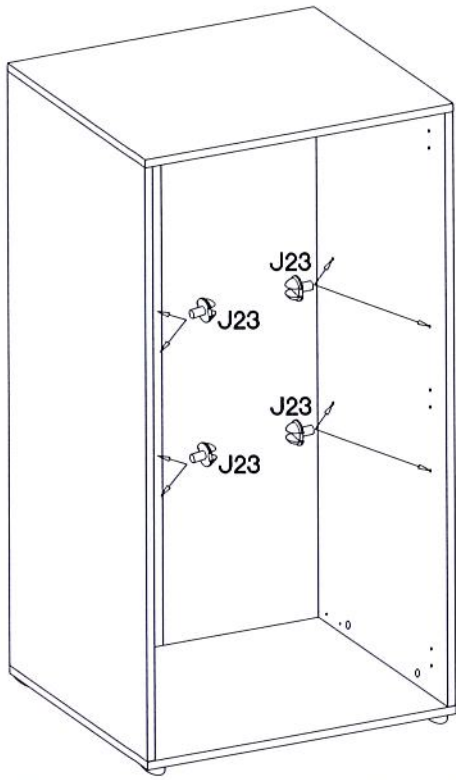

11



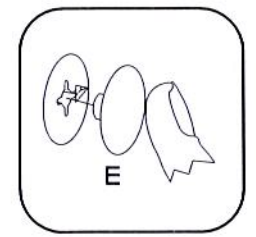
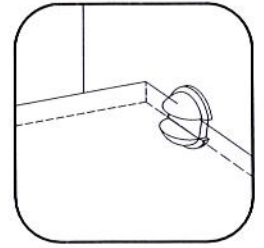

	
E	J23
8	8

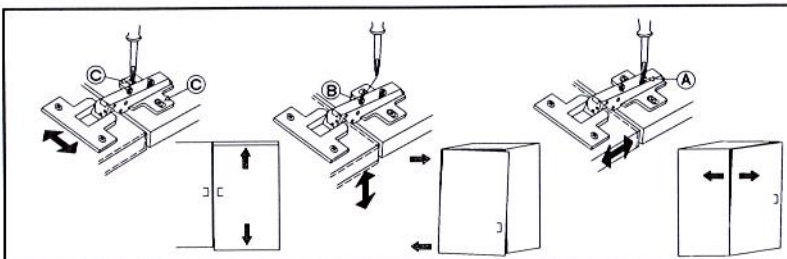
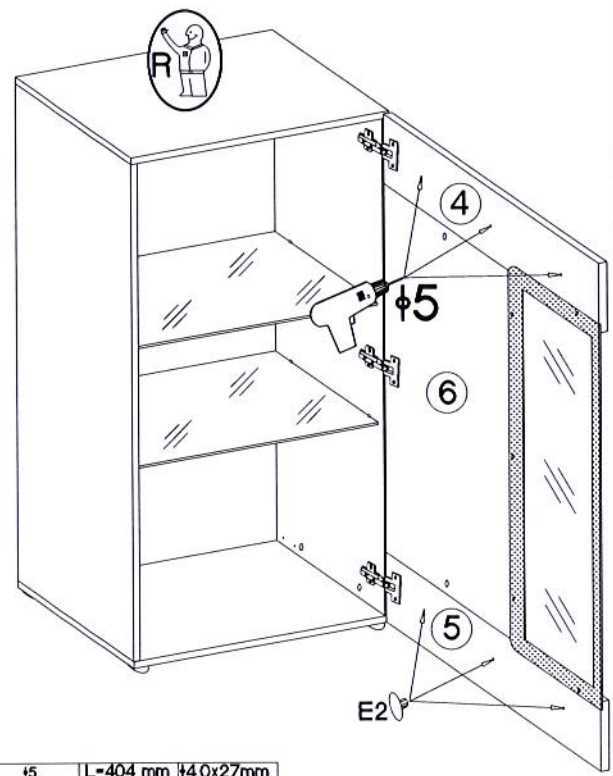
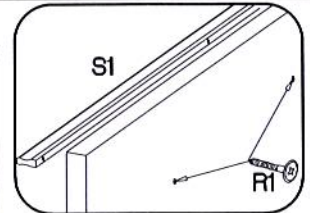
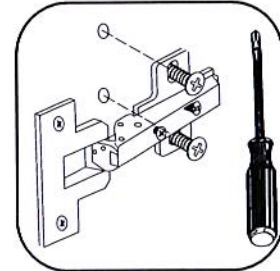
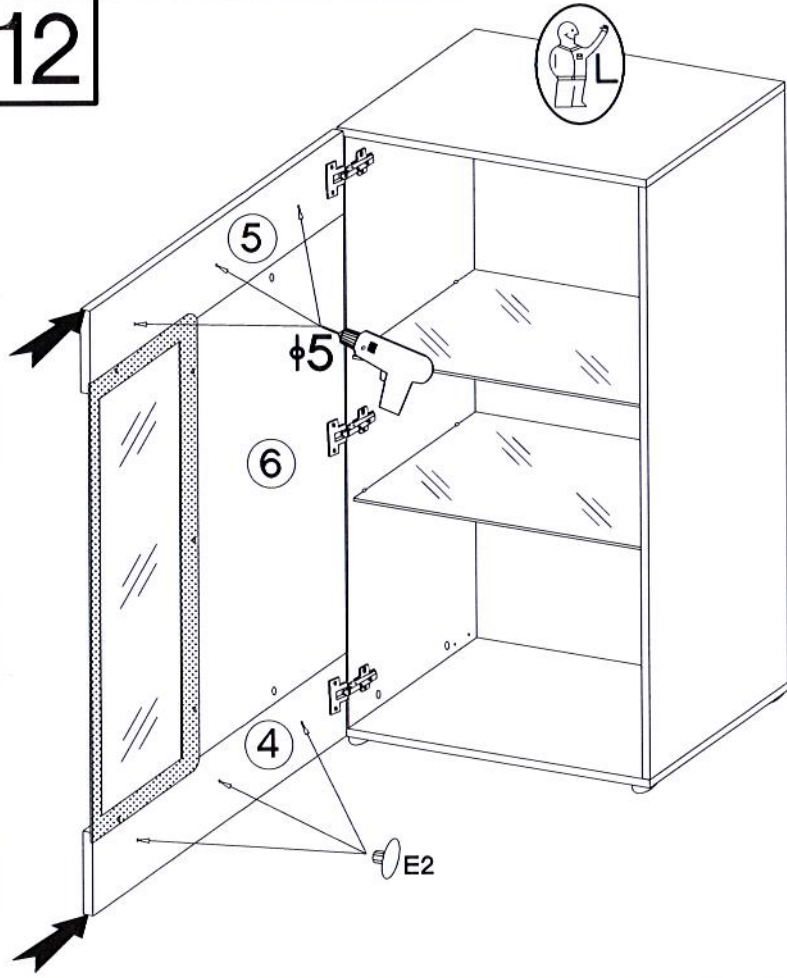

12



		
E2	S1	R1
3	1	3