

SKIN

Geben Sie hier den
 Modellnamen ein

1116-870-01
 1116-870-45
 1116-870-38

Geben Sie hier die
 Modellnummer ein

870

Geben Sie hier
 den Typ ein

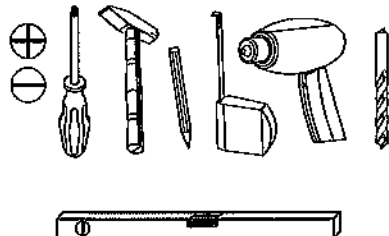
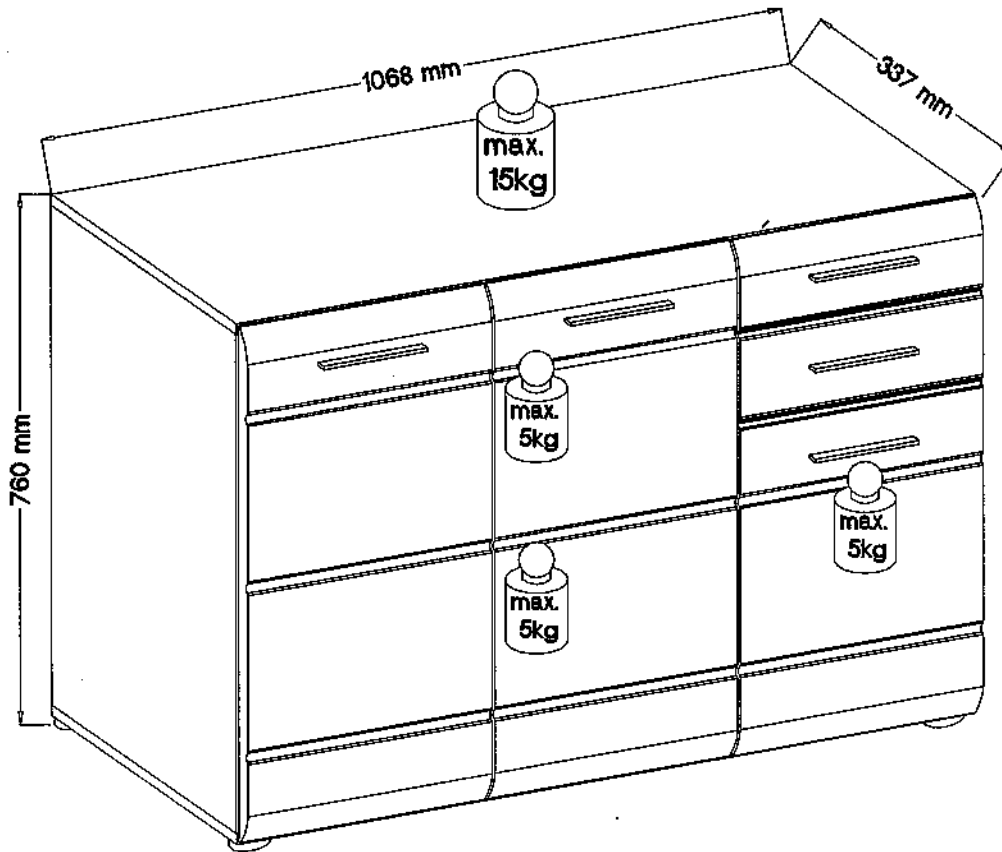
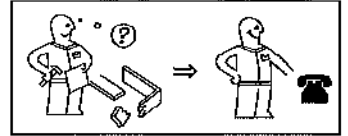
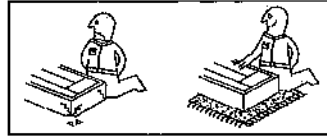
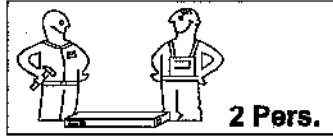
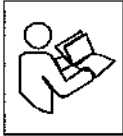

festziehen / tighten / Затягивать / serret /
 stringere / utáhnout / vaestrekkan / zategnuti /
 strängere / zwięzać / zaciśnąć ezotosen
 maghúzni / pevno doľahnuť / trdno prilagniti /
 затянуть / dia šli / šlar / Sikiñ



eindrücken / press in / enfoncez / wcisnąć
 ribattete / zallačiti / Вкореайте / indrücken
 benyomni / sllaciti / vstisñiti / tryck in / introduce
 prin apăsare / едавить / empujar / tçet bastiriñ



ausmessen / measure / mesurer / misurare /
 opmeten / izmeriti / milara / kímérni / izmeriti /
 măsurare / измерить / změřiti / Измеряте / mît
 upp / zmierzyc / medir / Ölçün



drücken / press / presser / sllsknout / Havichare
 / vstisñiti / nasinac / drukken / pritisnuti / nacenac /
 pñisñiti / Havjaty / (megjnyomni / apasare / tryck
 fael / haclenac / prestinar / Bastiriñ



einschlagen / hammer in / beværni / sla in / frapper au
 marteau / Infossare / Zabliti / zaraziti / Našiviti /
 zabliti / vbič / introduce prin bătăle / zabit /
 zallouct / clavar / tçet vurun



Drehen - wenden / przekreć - odwrócić / Keren
 - ondraalen / Girare - Ruotare / Okrenuti - obrnuti /
 Rebolmer - renverser / Turn over - turn around /
 Ofocte - obratiti / Zavrñate - obñerete / Obñite
 liet / Introarcat / rotiti / Vrid runi - vänd / prokrutyñ -
 повернуть / Ofočiti - obratiti / elforgaini - megfordítani /
 Gírar / Çevirñ

SKIN

Geben Sie hier den Modellnamen ein

1116-870-01
 1116-870-45
 1116-870-38

Geben Sie hier die Modellnummer ein

870

Geben Sie hier den Typ ein

D Unser Direktservice für Beschädigte
 Sollte Ihnen ein Beschädigter fehlen, können Sie diese Servicekarte direkt an die untenstehende Adresse schicken. Wir können allerdings nur Beschädigte auf diesem Wege verschicken. Sollen Sie eine andere Beantragung an Ihrem Möbelstück haben, so wenden Sie sich bitte direkt an Ihr Möbelhaus.

GB Our direct order service for fitting
 If a fitting part is missing, you can e-mail this service card directly to the address below. However, we can only send fitting parts in this way. If you have any other cause for complaint concerning your item of furniture, please contact your furniture store directly.

CZ Náša priama služba pre poškodené
 Čižeľ Vám niekedy chýba z kováňa, môžete toto servisní kartu odoslať e-mailom priamo na nižšie uvedenú adresu. Týmto spôsobom však môžeme zaslať len číly nábytok. Pokiaľ máte reklamáciu iným dli nábytku, obráťte sa priamo na svého predajcu nábytku.

F Bien utiliser la notice de montage
 Si l'un des éléments de montage est manquant, veuillez envoyer directement la présente carte de service à l'adresse e-mail indiquée ci-dessous. Cependant, nous ne pouvons uniquement envoyer des fournitures. Pour tout autre type de réclamation concernant votre meuble, veuillez contacter directement votre magasin d'ameublement.

I Il nostro servizio diretto per l'ordine della ferramenta
 Qualora Vi dovesse mancare un pezzo di fissaggio, allora Vi preghiamo di inviare questa carta di servizio immediatamente all'indirizzo sottostante. Possiamo inviare i pezzi di fissaggio solamente per mezzo di questo procedimento. Qualora dovesse avere qualche altra reclamazione in merito al mobile, allora Vi preghiamo di rivolgerVi direttamente al Vostro Negozio di mobili.

BG Наша пряма услуга за обнова
 Ако липсват части от комплекта, потърнете настоящата сервисна карта и ни я изпратете на e-mail адреса, посочен по-долу. По този начин можем да доставим само фитингите и винтовете от обнова. Ако установите други дефекти по мебелите, Вие съветваме да се обърнете към мебелната къща/магазин, от който сте закупили стоката.

NL Onze directservice voor beschadigde
 Wanneer er een onderdeel ontbreekt, kunt u deze servicekaart direct aan onderstaand e-mailadres sturen. Wij kunnen sngs deze weg echter alleen beschadigde verstuuren. Mocht u een ander probleem aan uw meubel hebben, verzoekten wij u contact op te nemen met uw meubeldealer.

PL Nasz bezpośredni serwis części montażowych
 Jeżeli brakuje części konstrukcyjnych do montażu, prosimy o przesłanie nam niniejszej karty serwisowej na niżej podany adres e-mailowy. W ten sposób możemy przesłać jedynie części konstrukcyjne. W przypadku innych reklamacji dotyczących mebla, prosimy zgłosić się do salonu meblowego, w którym został dokonany zakup.

HR Služba za okovicu
 U slučaju da nedostaje neki od dijelova molimo vas da ne dođe navedeno mail adresu potražite ovaj servisni obrazac. Na ovaj način mogu doći samo okovicu. U slučaju da imate dodatne prigovore vezane uz karmat namještaja molimo vas da se obratite izvorno trgovini namještaja gdje je isti kupljen.

HU Direktszolgálatunk vasalattal együtt
 Ha hiányzik egy vasalat, ezt a Kártyát közvetlenül elküldheti az alábbi látható címre. Azonban csak a vasalattal együtt küldeni. Amennyiben másféle reklamáció áll fenn a bútorcseregelés tekintetében, forduljon közvetlenül a boltvezetőhöz.

SK Náš priamy servis pre poškodené
 Ak by Vám niekedy chýbala časť kováňa, môžete poslať túto servisnú kartu priamo e-mailom na nižšie uvedenú adresu. Týmto spôsobom však môžeme zaslať iba spojovací materiál. Ak by ste mali inú reklamáciu u nábytku, obráťte sa priamo na Vašu predajcu nábytku.

SLO Náša direktna usluga storitve za okovicu
 Če vam manjka kakšno okovicu, lahko to servisno kartico pošljete po e-pošti direktno na spodnji naslov. Po tej poti vam lahko pošljemo samo okovicu. Če želite reklamirati kaj drug dal pohištva, se obrnite neposredno na vašo trgovino pohištva.

RO Service-ul nostru direct pentru feronerie
 În cazul în care vă lipsesc o piesă de feronerie purtați ea înmănușiți direct acest card de service prin e-mail la adresa de mai jos. Noi nu putem expedia piese de feronerie decât pe această cale. Dacă aveți o altă reclamație referitoare la piesa de mobilier, atunci vă rugăm să vă adresați direct la magazinul dvs. de mobilier.

RUS Наш прямой сервис для поставок фурнитуры
 Если окажется, что Вам не хватает того или иного элемента фурнитуры, Вы можете отправить сервисную карту по факсу непосредственно на нижеприведенный адрес электронной почты. Однако, таким образом мы можем пересылать лишь фурнитуру. Если же у Вас возникнут иные претензии относительно приобретенной мебели, пожалуйста, обращайтесь непосредственно в организацию, осуществившую продажу.

S Vår direktservice för beskadigade
 Om du saknar en beskadigad del kan du skicka detta servicekort direkt till e-postadressen som anges nedan. Tänk på att detta är den enda möjligheten att skicka beskadigade delar till dig. Om du vill reklamera din möbel av annan anledning måste du kontakta ditt möbelhus direkt.

ES Nuestro servicio directo para accesorios
 Si la falta algún accesorio, puede enviar esta tarjeta de servicio directamente a la siguiente dirección. No obstante, por este método solo podemos enviar accesorios. Si tiene alguna otra objeción sobre su mueble, consulte directamente con su mueblería.

TR Donatırız için doğrudan servisimiz
 Bir donatırız eksikse bu servis kartını doğrudan aşağıda bulunan adrese doğrudan mail yoluyla gönderebilirsiniz. Sadece bu yolla donatırız gönderilebilir. Mobilyanızda başka şikayetiniz varsa lütfen doğrudan mobilya satıcınıza danışın.

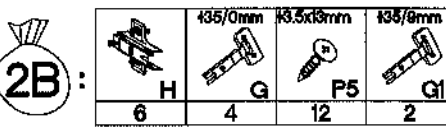
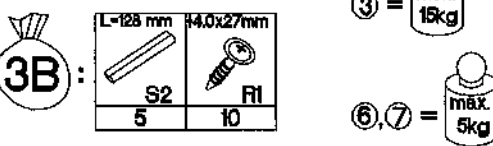
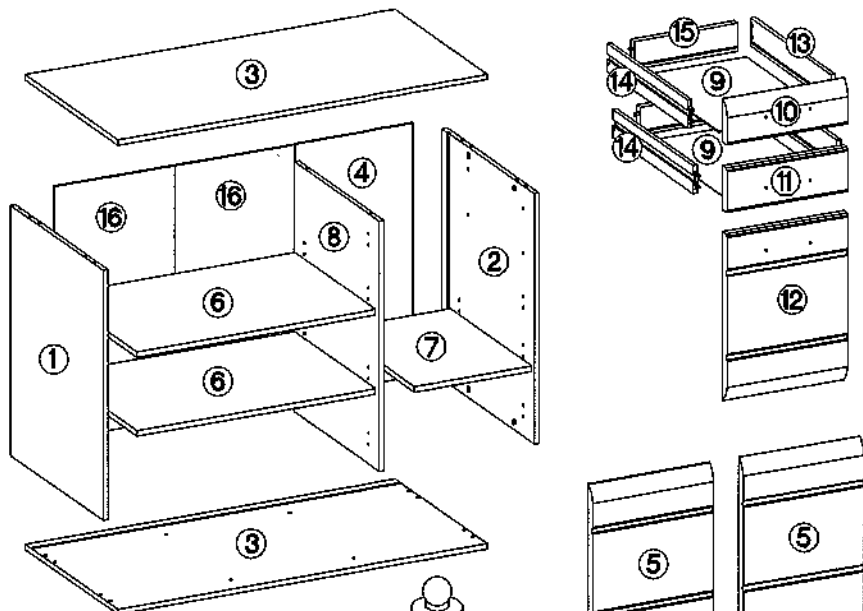

15.0x13mm	L=708mm	16x42mm	17/2mm	13.5x13mm	18x50mm	15/16mm	M4x9mm	
M	L1	B2	J5	P5	O12	L9	U1	O1
8	1	4	10	1	1	12	4	1
	15x20mm	L=20mm	H6/12mm		13.0x20mm		F10	E2
	A	D2	C	E	L		5	4
8	12	12	8	10	5	5	5	2

LKZ 80106

Grund der Beanstandung / Reason of the objection:

Möbelhaus / Furniture store:

Name / Name: _____ Telefon / Telephone: _____

PLZ / postal code: _____ Ort / City: _____

Strasse / Street: _____

Haus-Nr. / House No.: _____ @E-Mail: _____

1

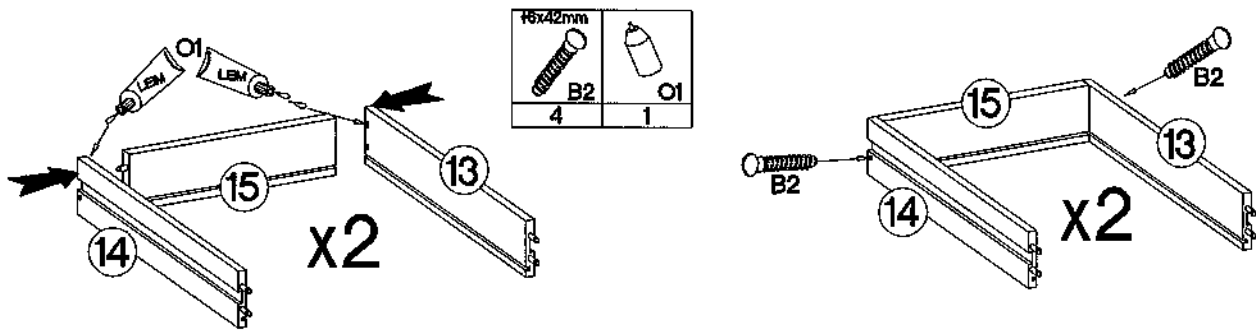



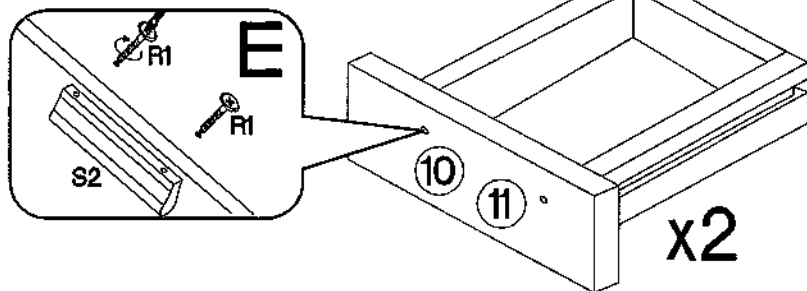
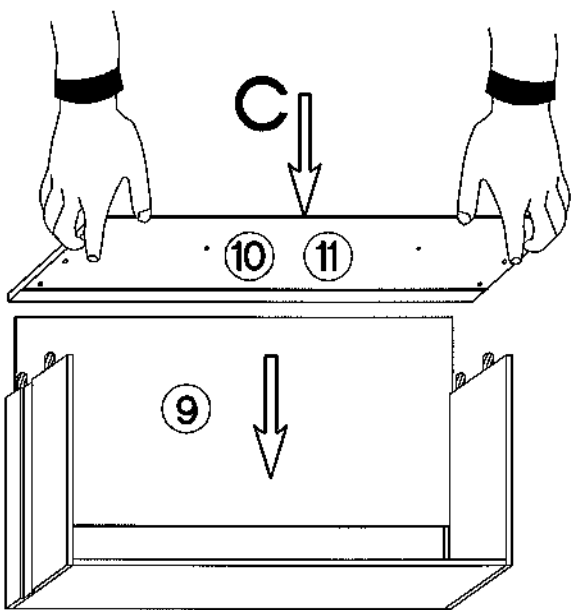
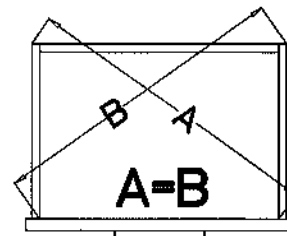
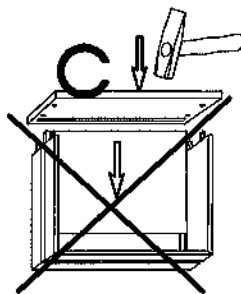
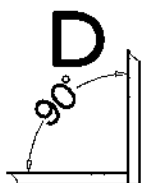
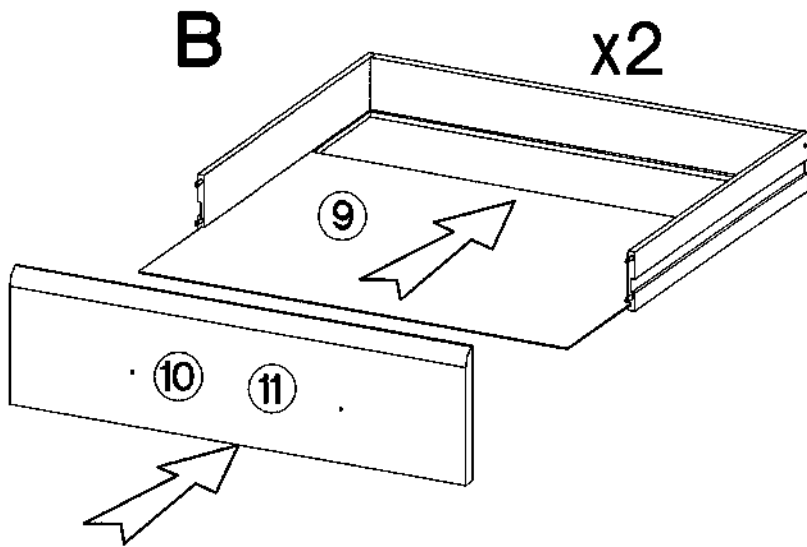
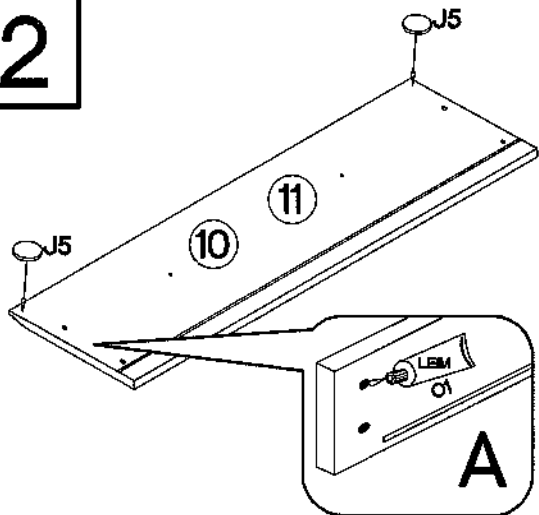



2



4	1	2	4
J5	O1	S2	R1
17/2mm	L-128 mm	4.0x27mm	

3

 18x30mm A	 L=20mm D2	 H5/2mm C	 t6.0x19mm M	 7/24mm I	 F10	 t4.0x25mm P14
8	12	12	8	2	5	5

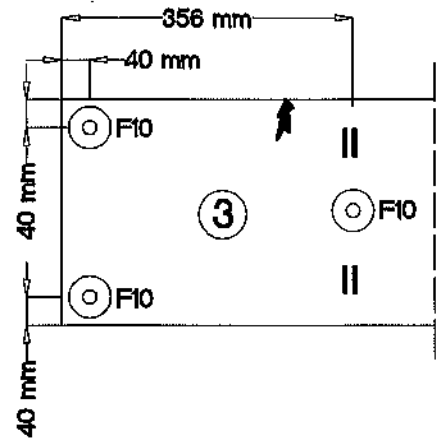
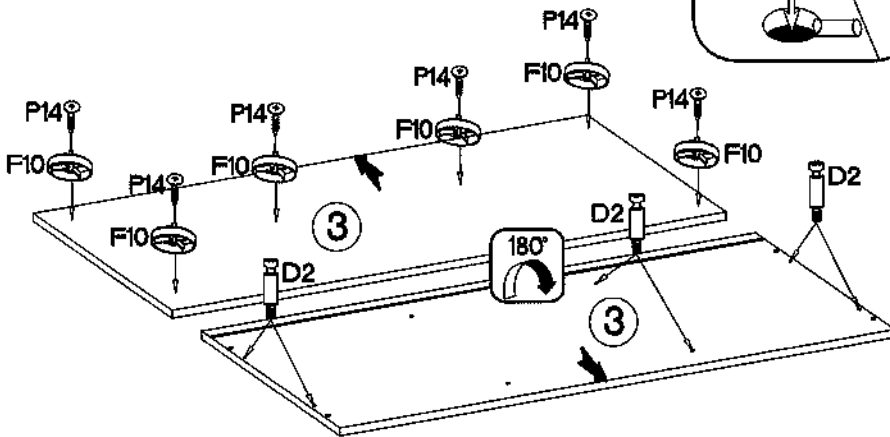
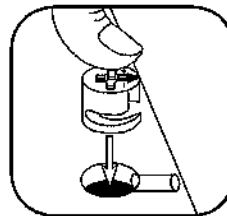
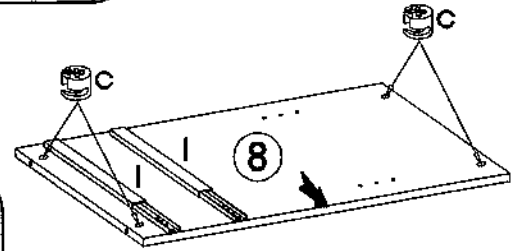
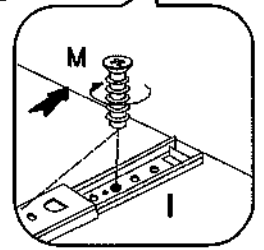
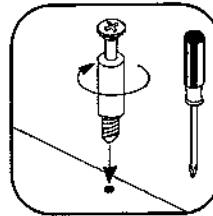
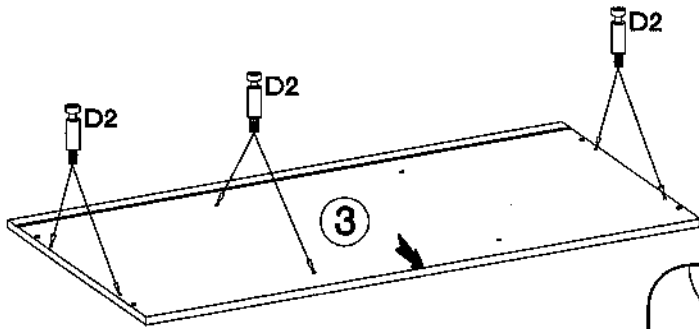
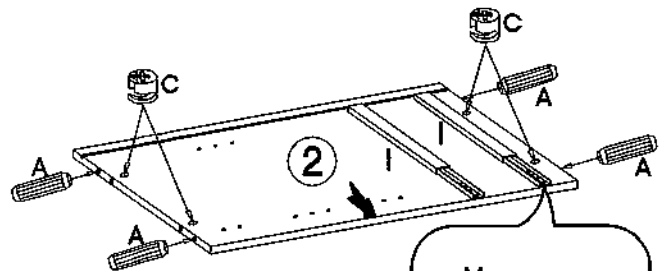
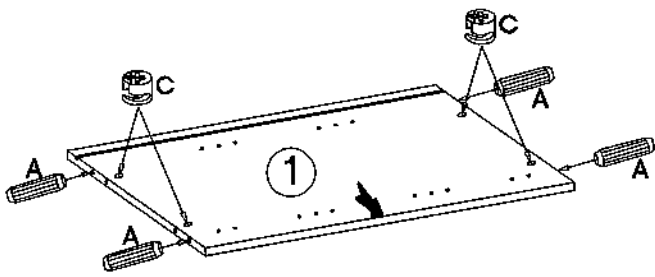

4

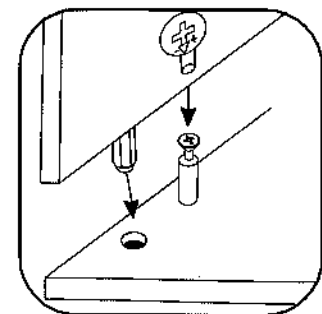
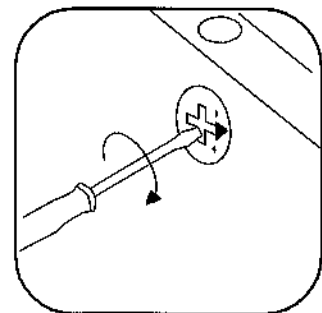
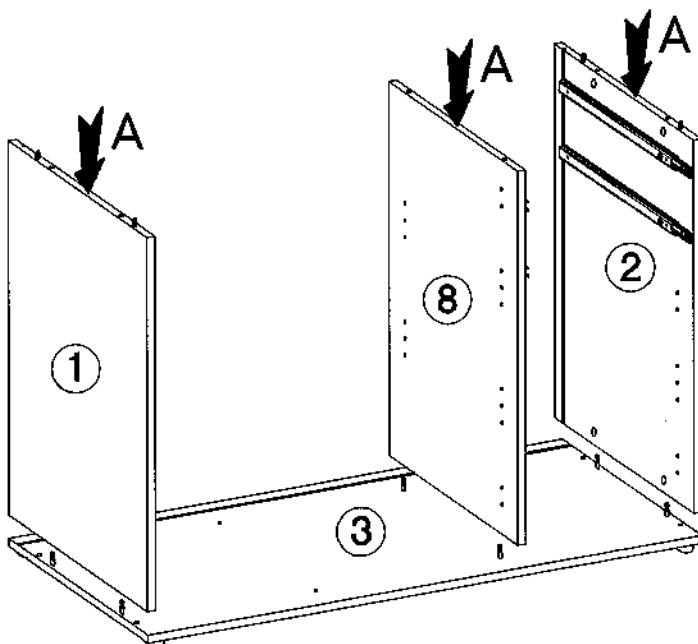

5

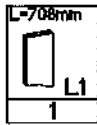
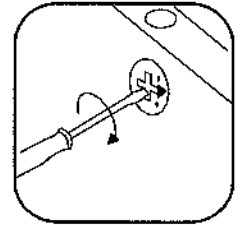
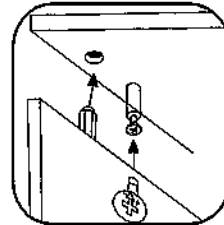
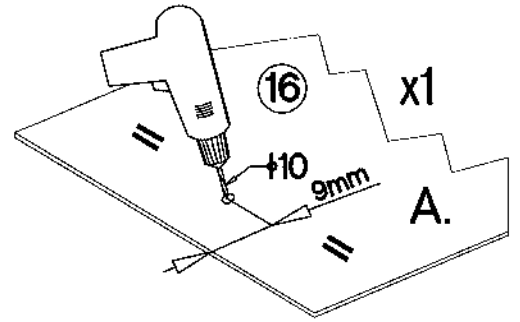
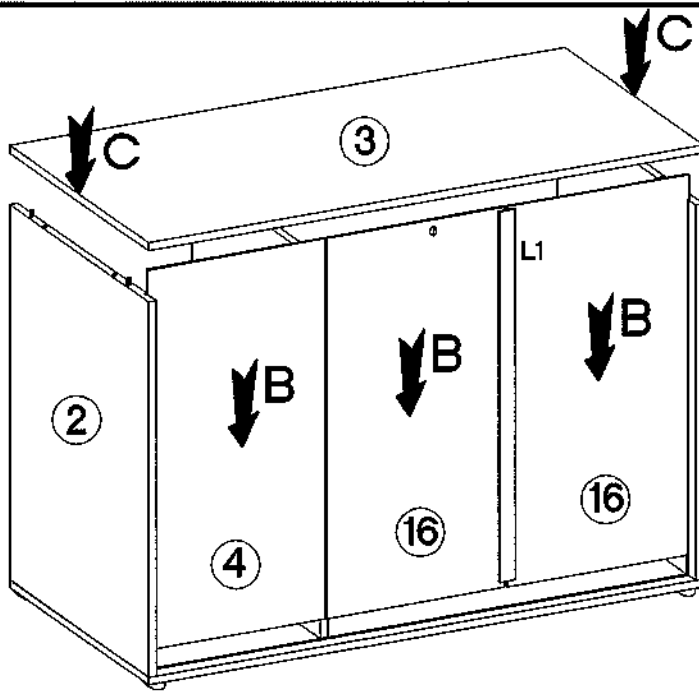

6

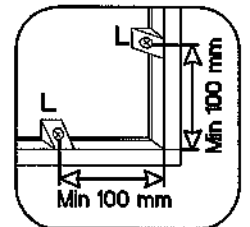
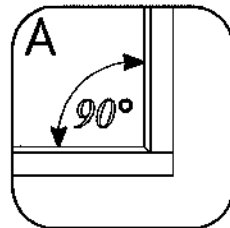
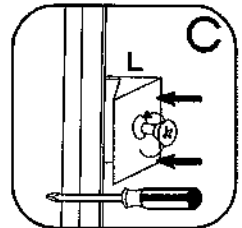
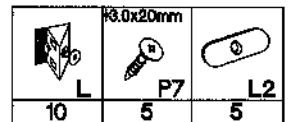
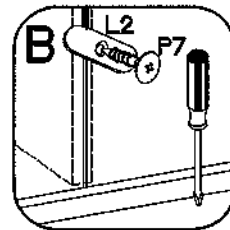
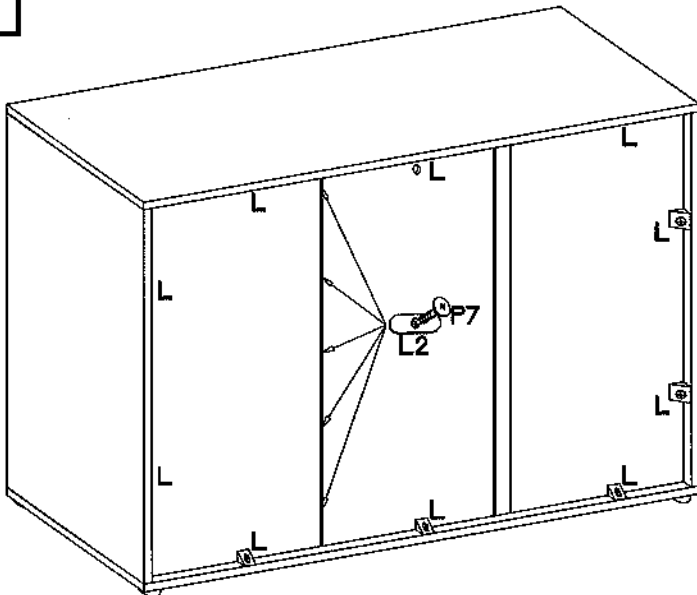

7

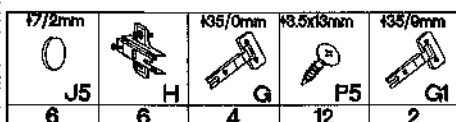
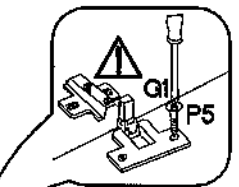
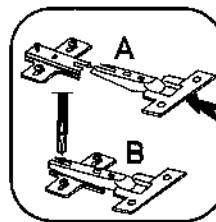
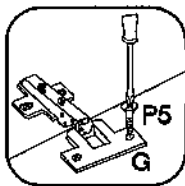
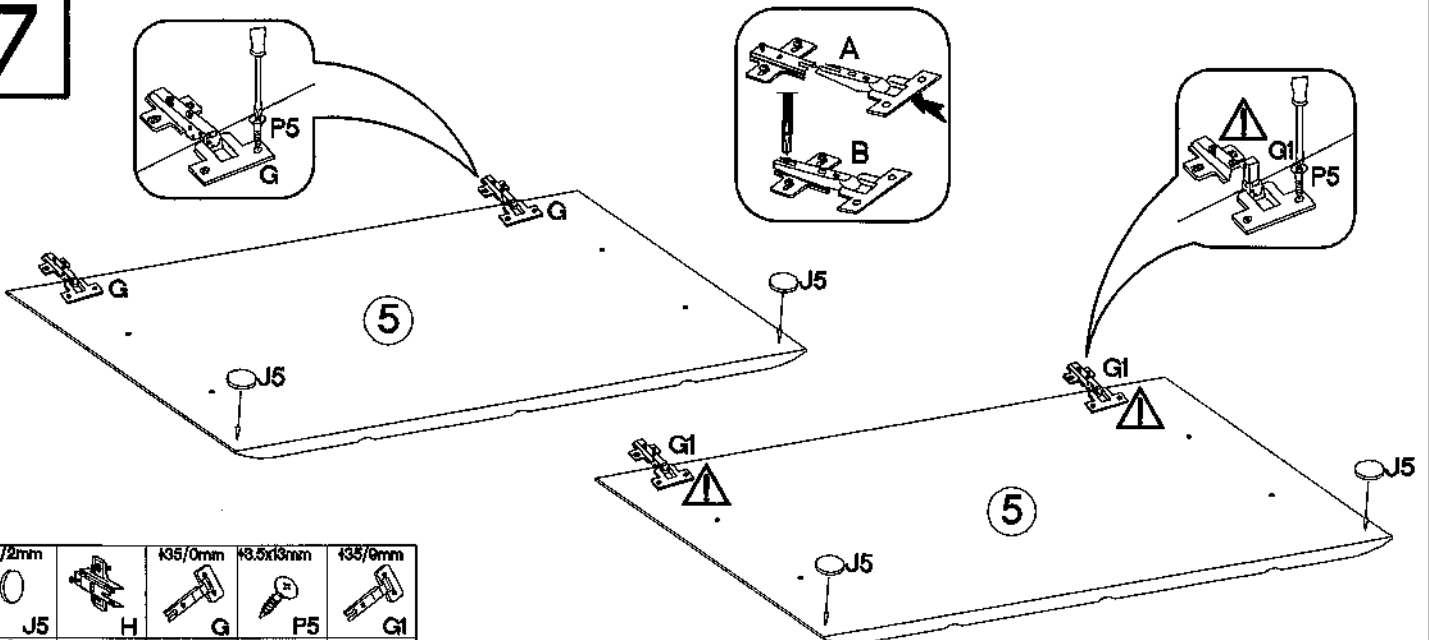

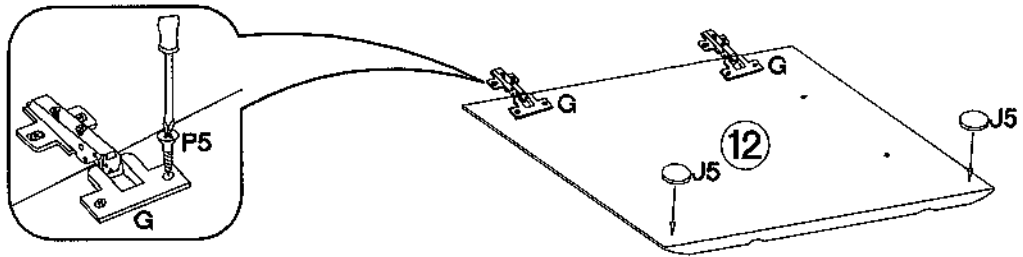



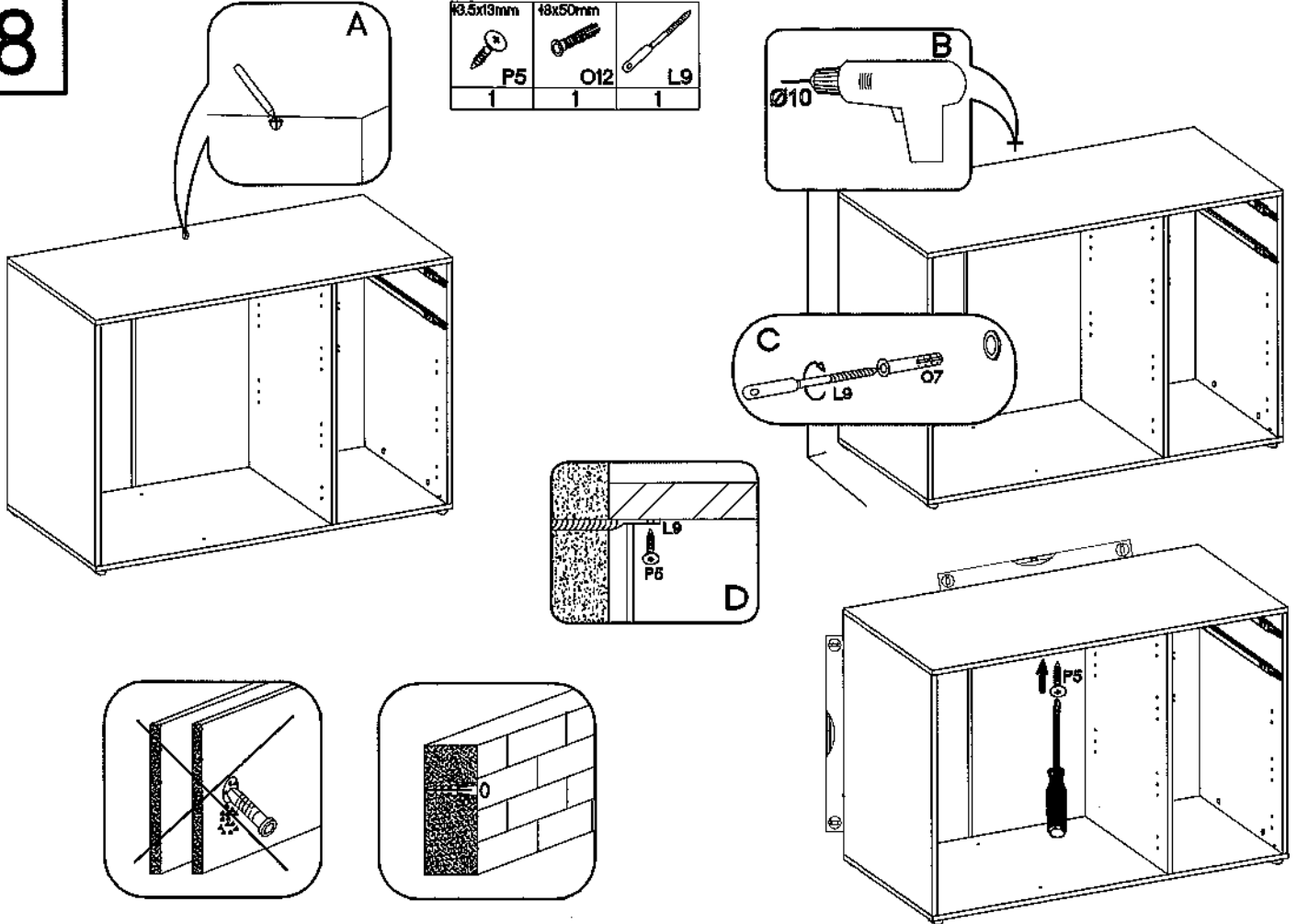

8

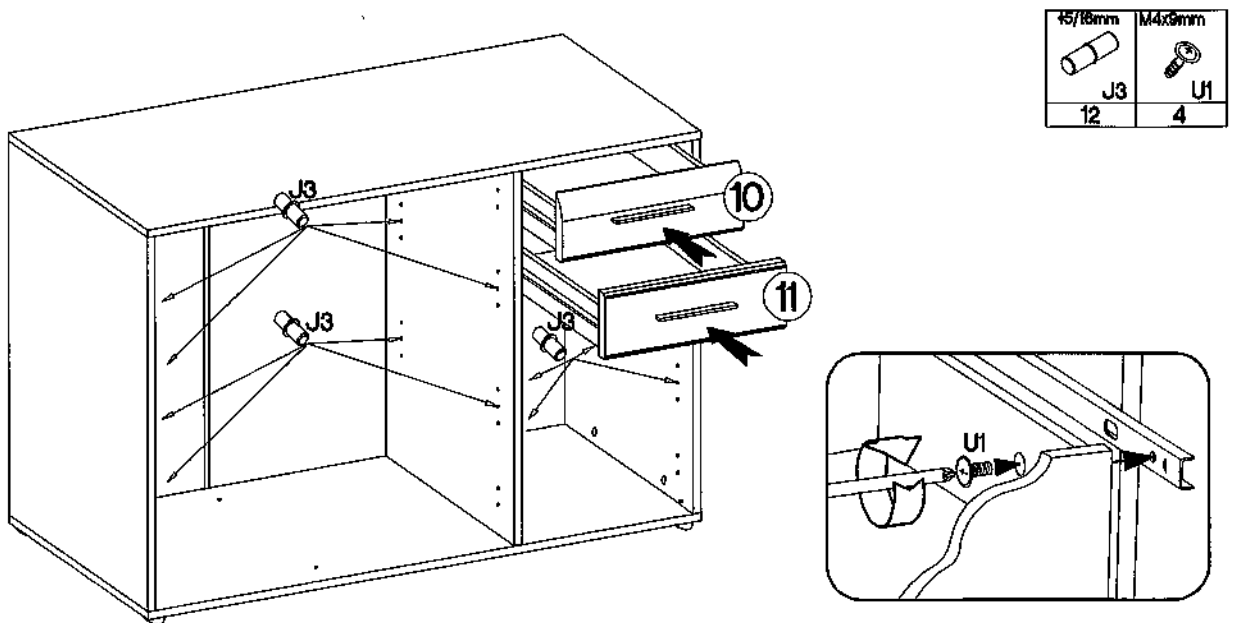

9



10

 E2	 E	 S2	 R1
4	8	3	6

