

# HIGH TEC

Geben Sie hier den  
 Modellnamen ein

1329-125-02

Geben Sie hier die  
 Modellnummer ein

# 125

Geben Sie hier  
 den Typ ein

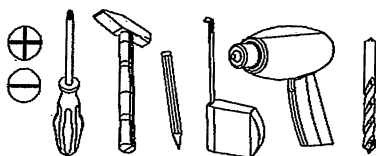
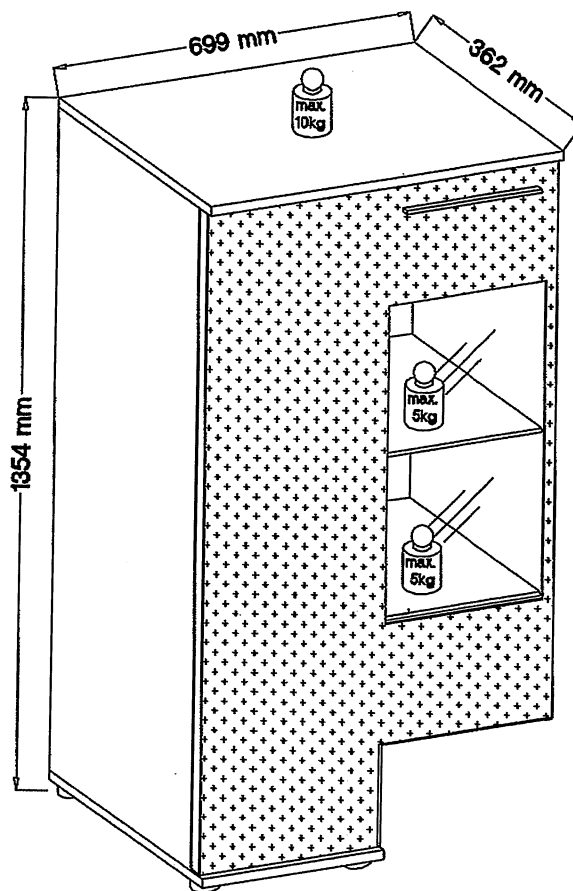
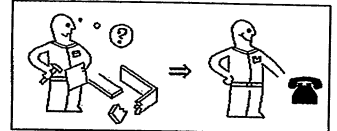
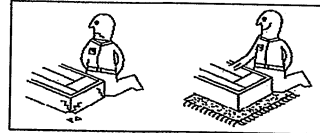

festziehen / tighten / Затягивать / serrer /  
 stringere / utáhnout / vastretikken / zategnuti /  
 strängere / zvlazac / zacisnąć szorosan /  
 meghúzni / pevno dotáhnout / trdno pritegniti /  
 затянуть / dta át / tjar / Sıkın



eindrücken / press in / enfoncer / wdsnąć  
 ribattere / zallačit / Вкрасяйте / Indrukken  
 benyomni / sbacit / vtisnit / tryck in / introduce  
 prin apă sare / едавить / empujar / İceri bastırın



ausmessen / measure / mesurer / măsurare /  
 орметен / Izmeriti / mlara / kíméni / Izmeriti /  
 măsurare / Измерить / změřit / Измерете / mät  
 upp / zmierzyc / medti / Ölçün



drücken / press / presser / stisknout / Натиснете  
 / vtisnit / nasloac / drukken / pritisnuti / nacisnac /  
 pritisnit / нажать / (megnyomni) / apasara / tryck  
 fast / nacisnąć / prestonar / Bastırın



einschlagen / hammer in / beveini / sia in / frapper au  
 marteau / infossare / Zabit / zarađi / Načivare /  
 zabiti / whic / Introduce prin bălate / забить /  
 zatouci / clavar / İceri vurun



Drehen - wenden / przekreć - odwrócić / Keren  
 - omdraalen / Girare - Ruotate / Okrenuti - ubrnuti /  
 Retourner - renverser / Turn over - turn around /  
 Ocloce - obratite / Завъртете - обърнете / Obvrtilo  
 list / Inbarceji - rolij / Vrid runt - vänd / прокрутить -  
 повернуть / otociti - obrati / elforgalni - megfordítani /  
 Girar / Çevirin

**HIGH TEC**  
Geben Sie hier den  
Modellnummer ein

1329-125-02   
Geben Sie hier die  
Modellnummer ein

**125**  
Geben Sie hier  
den Typ ein

**D Unser Direktservice für Beschädigte**  
Sollte Ihnen ein Beschädigter fehlen, können Sie diese Servicekarte direkt an die untenstehende Adresse mailen. Wir können allerdings nur Beschädigte auf diesem Wege verschicken. Sollten Sie eine andere Beanstandung an Ihrem Möbelstück haben, so wenden Sie sich bitte direkt an Ihr Möbelhaus.

**GB Our direct order service for fitting**  
If a fitting part is missing, you can e-mail this service card directly to the address below. However, we can only send fitting parts in this way. If you have any other cause for complaint concerning your item of furniture, please contact your furniture store directly.

**CZ Naše přímé služby pro kování**  
Chybí-li vám nějaký díl z kování, můžete tuto servisní kartu odeslat e-mailem přímo na níže uvedenou adresu. Touto cestou však můžeme rozaslat jen díly kování. Pokud byste reklamovali jiný díl nábytku, obraťte se přímo na svého prodejce nábytku.

**F Bien utiliser la notice de montage**  
Si vous manque une ferrure, veuillez envoyer directement la présente carte service à l'adresse e-mail indiquée ci-dessous. Cependant, ceci nous permet uniquement d'envoyer des ferrures. Pour tout autre type de réclamation concernant votre meuble, veuillez contacter directement votre magasin d'aménagement.

**I Il nostro servizio diretto per l'ordine della ferramenta**  
Qualora Vi dovesse mancare un pezzo di fissaggio, allora Vi preghiamo di inviare questa carta di servizio immediatamente all'indirizzo sottostante. Possiamo inviare i pezzi di fissaggio solamente per mezzo di questo procedimento. Qualora dovesse avere qualche altra reclamazione in merito al mobile, allora Vi preghiamo di rivolgerVi direttamente al Vostro Negozio di mobili.

**BG Нашата директна услуга за обкова**  
Ако липсват части от комплекта, попълнете настоящата сервисна карта и ни я изпратете на e-mail адреса, посочен по-долу. По този начин можем да доставим само разсадни елементи от обкова. Ако искате да се обърнете към нас по отношение на друг дефект на мебелта, моля, свържете се директно с магазина, от който сте закупили стоката.

**NL Onze directservice voor losse onderdelen**  
Wanneer er een onderdeel ontbreekt, kunt u deze servicekaart direct aan onderstaand e-mailadres sturen. Wij kunnen langs deze weg echter alleen beslagdelen verzenden. Mocht u een ander probleem aan uw meubel hebben, verzoeken wij u contact op te nemen met uw meubeldealer.

**PL Nasz bezpośredni serwis części montażowych**  
Jeżeli brakuje części koniecznych do montażu, prosimy o przesłanie nam niniejszej karty serwisowej na niżej podany adres e-mailowy. W ten sposób możemy przysłać Państwu tylko brakujące części. W przypadku innych reklamacji dotyczących mebla, prosimy zgłosić się do salonu meblowego, w którym został dokonany zakup.

**HR Servis za okove**  
U slučaju da nedostaje neki od dijelova možemo vas da na doleja navodenu mail adresu pošaljemo ovaj servisni obrazac. Na ovaj način mogu se dostaviti samo okovi. U slučaju da imate dodatne prigovore vezane uz komad namještaja možemo vas da se obratimo izravno trgovini namještaja gdje je isti kupljen.

**HU Direktszolgálatunk vasalatók esetén**  
Ha hiányzik egy vasalát, ezt a kártyát közvetlenül elküldheti az alábbi felcímezett címre. Azonban csak vasalatókat tudunk így küldeni. Amennyiben másféle reklamációt állít fel, kérjük forduljon a boltjához, ahol megvásárolta a bútort.

**SK Naše priamy servis pre častí kování**  
Ak by Vám chýbala nejaká časť kování, môžete poslať túto servisnú kartu pošou e-mailom na nižšie uvedenú adresu. Diely kování vieme poslať iba týmto spôsobom. Ak by ste mali inú reklamáciu súvisiacu s Vaším nábytkom, obráťte sa priamo na Vašu predajňu nábytku.

**SLO Naše direktno uslugno storitve za okovje**  
Če vam manjka kakšno okovje, lahko to servisno kartico pošljete po e-pošti direktno na spodnji naslov. Po tej poti vam lahko pošljemo samo okovje. Če želite reklamirati kakšen drug del pohištva, se obrnite neposredno na vašo trgovino pohištva.

**RO Serviciul nostru direct pentru feronerie**  
În cazul în care vă lipsește o piesă de feronerie puteți să trimiteți direct acest card de service prin e-mail la adresa de mai jos. Noi nu putem expedia piese de feronerie decât pe această cale. Dacă aveți o altă reclamație referitoare la piesa de mobilier, atunci vă rugăm să vă adresați direct la magazinul dvs. de mobilier.

**RUS Наши прямой сервис для поставок фурнитуры**  
Если окажется, что Вам на комплект того или иного элемента фурнитуры. Вы можете отправить сервисную карту по факсу непосредственно на нижеприведенный адрес электронной почты. Однако, таким образом мы можем переслать лишь фурнитуру. Если же у Вас возникнут иные претензии относительно приобретенной мебели, пожалуйста, обращайтесь непосредственно в организацию, осуществляющую продажу.

**S Vår direktservice för beslagdelar**  
Om du saknar en beslagdel kan du skicka detta servicekort direkt till e-postadressen som anges nedan. Tänk på att detta är den enda möjligheten att skicka beslagdelar till dig. Om du vill reklamera din möbel av en annan anledning måste du kontakta ditt möbelhus direkt.

**ES Nuestro servicio directo para accesorios**  
Si le falta algún accesorio, puede enviar esta tarjeta de servicio directamente a la siguiente dirección. No obstante, por este método solo podemos enviar accesorios. Si tiene alguna otra objeción sobre su mueble, consulte directamente con su mueblería.



**TR Donatınız için doğrudan servisimiz**  
Bir donatınız eksikse bu servis kartını doğrudan aşağıda bulunan adrese doğrudan mail yazabilirsiniz. Sadece bu yolla donatıları gönderebiliriz. Mobilyanızda başka şikayetleriniz varsa lütfen doğrudan mobilya satıcımıza danışın.



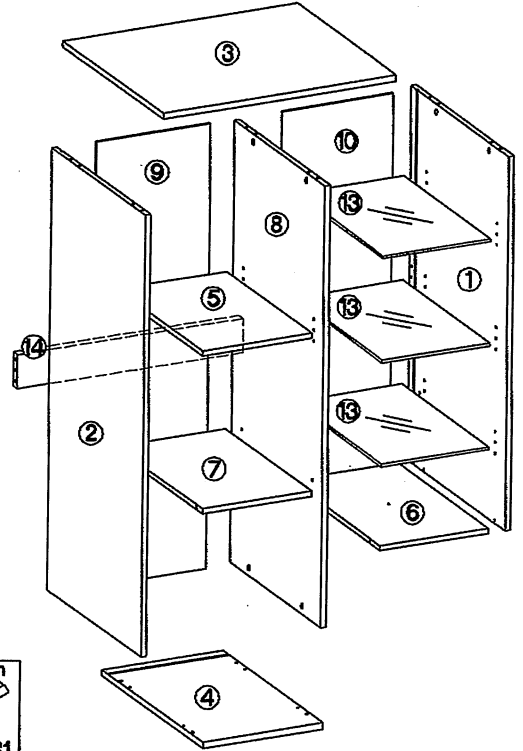
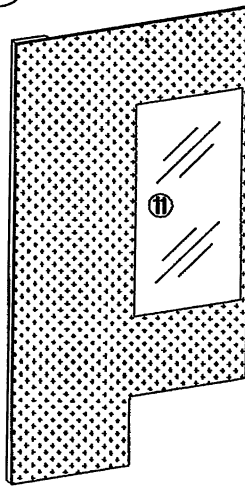

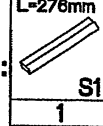
⑤, ⑦, ⑬ =  max. 5kg

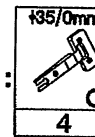
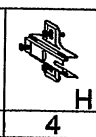
③ =  max. 10kg

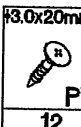
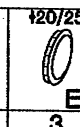
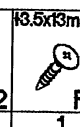
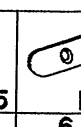
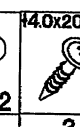
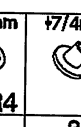
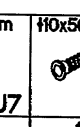

 3B :  L=27/6mm S1 1

 2B :  +35/0mm G 4  H 4  +3.5x13mm P5 8

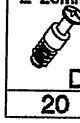
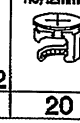
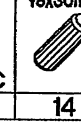
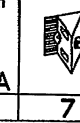
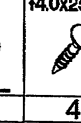
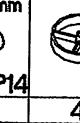
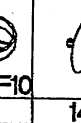
 P7 12	 E12 3	 P5 1	 L2 6	 R4 3	 J7 3	 O7 1	 L9 1	 J3 4
 D2 20	 C 20	 A 14	 L 7	 P14 4	 F10 4	 E 14	 J12 12	

LKZ 80106

Grund der Beanstandung / Reason of the objection:

Möbelhaus / Furniture store:

Name / Name:

Telefon / Telephone:

PLZ / postal code:

Ort / City:

Strasse / Street:





Haus-Nr. / House No.:

@E-Mail:

E-Mail Kundenservice / Customer service e-mail / E-mail servisního střediska / E-mail de notre service clientèle / e-mail servizio clienti / E-mail na otzema za obsluževane na klienti / E-mail klantenservice / E-mail serwisu dla klientów / Servisna mail adresa / Az ügyfélszolgálat e-mail címe / E-mail zákaznického servisu / E-pošta Servisna služba / E-mail Servisu clienții / E-Mail сервисной службы / E-postadress kundservice / Servicio de atención por correo electrónico / Müşteri hizmetleri e-postası

service-ff@trendteam.eu  
Hotline: +49 5233 955 0367  
Fax: +49 5233 955 0467

# 1

 L-20mm D2	 #5/12mm C	 t8x30mm A	 t4.0x25mm P14	 F10
20	20	14	4	4

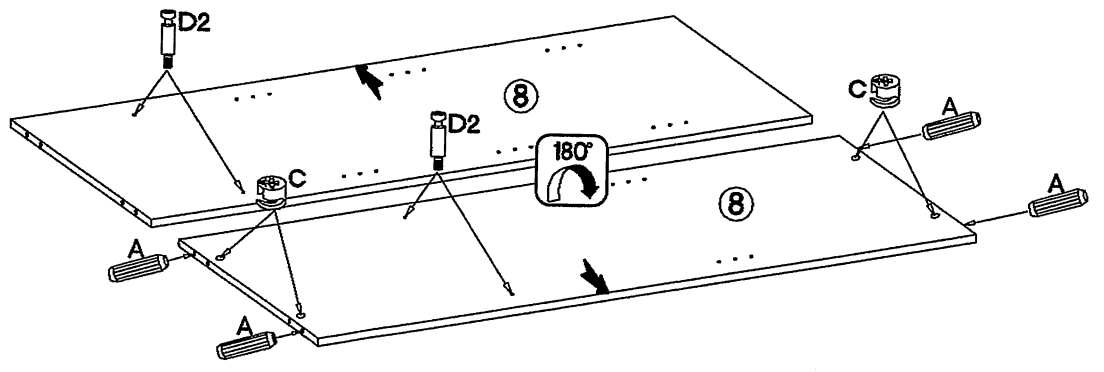
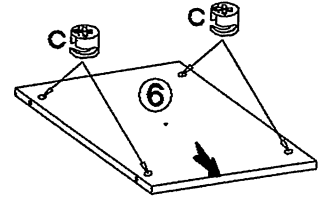
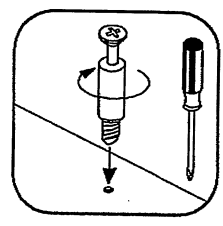
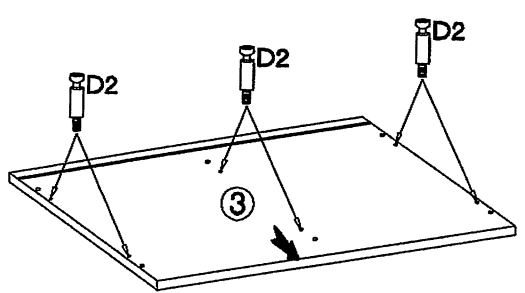
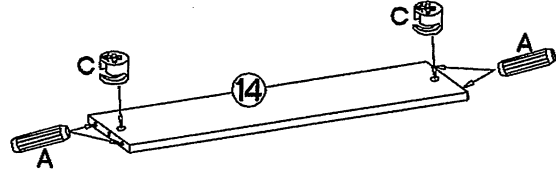
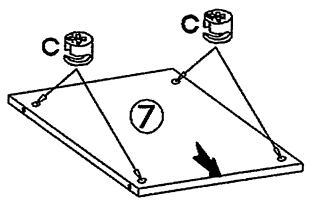
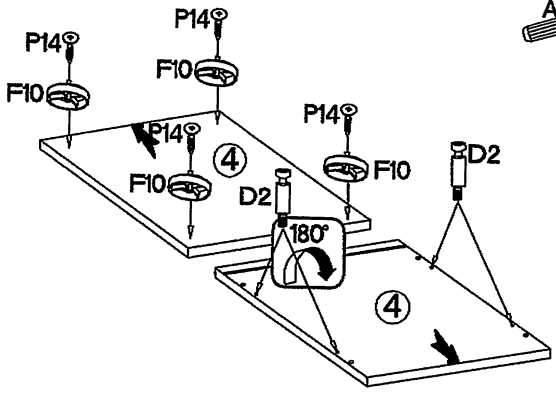
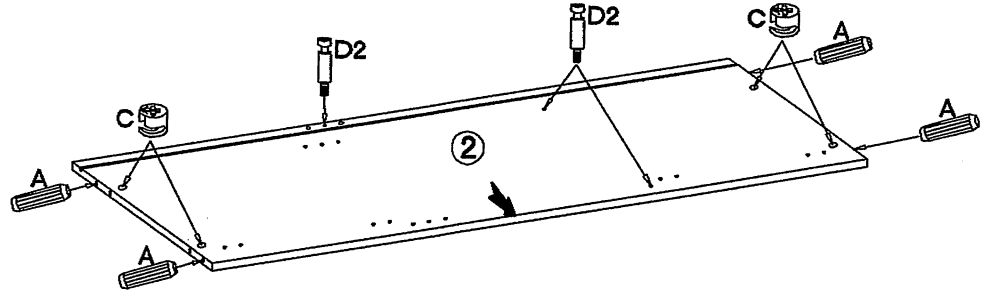
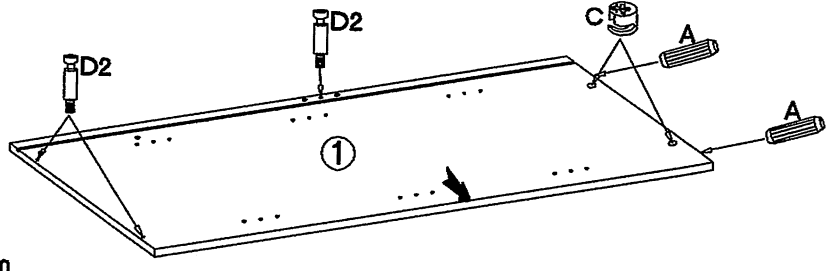
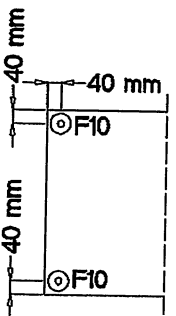
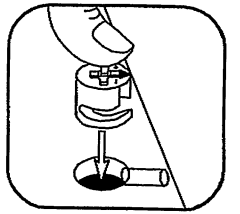

2

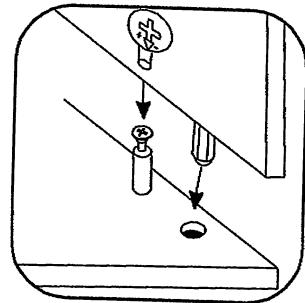
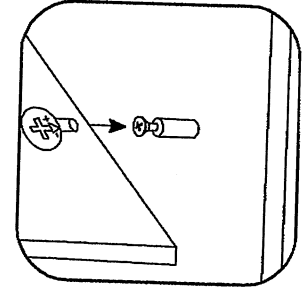
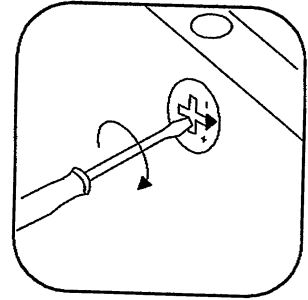
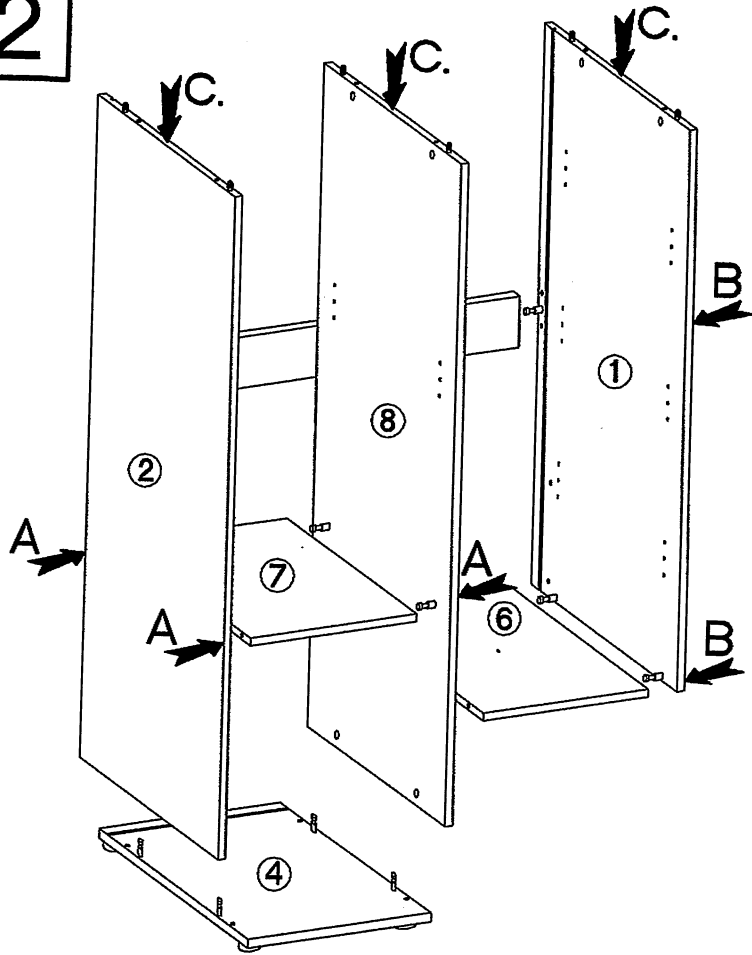

3

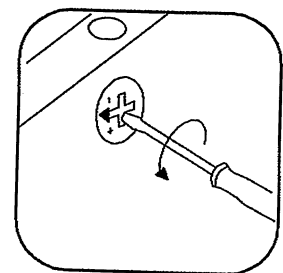
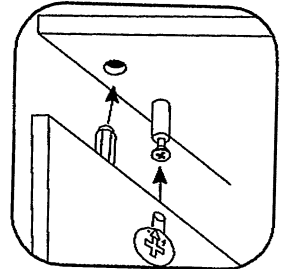
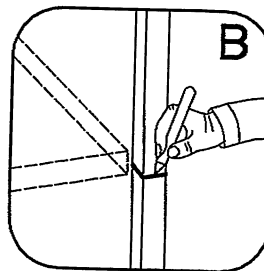
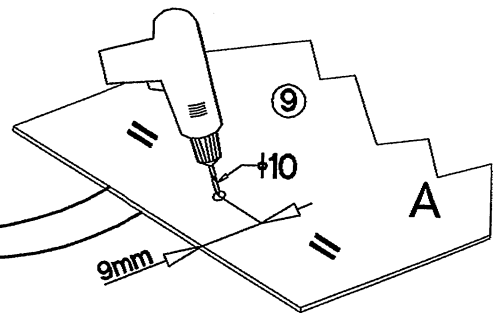
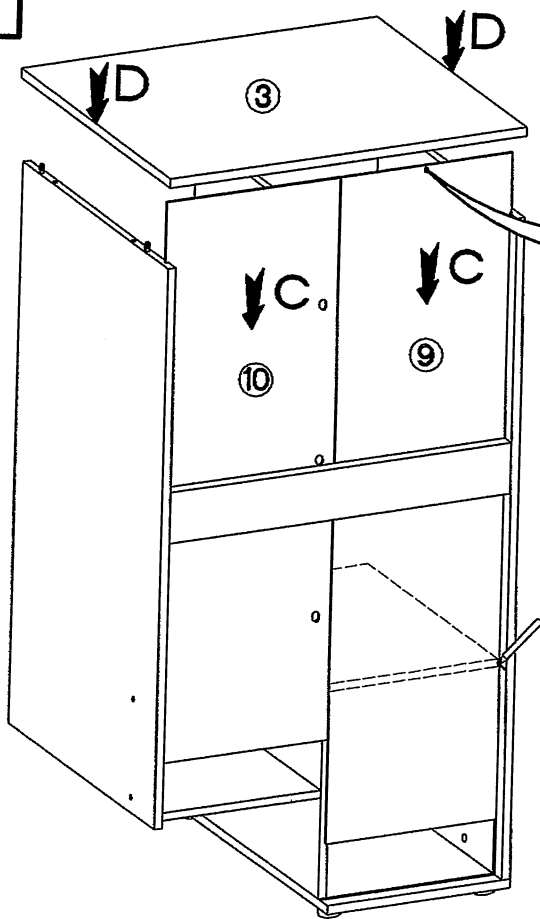

4

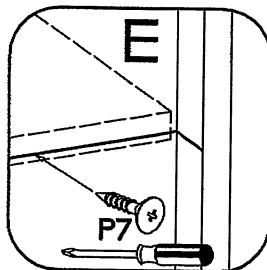
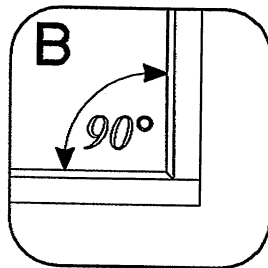
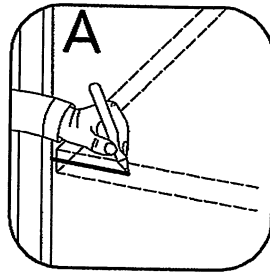
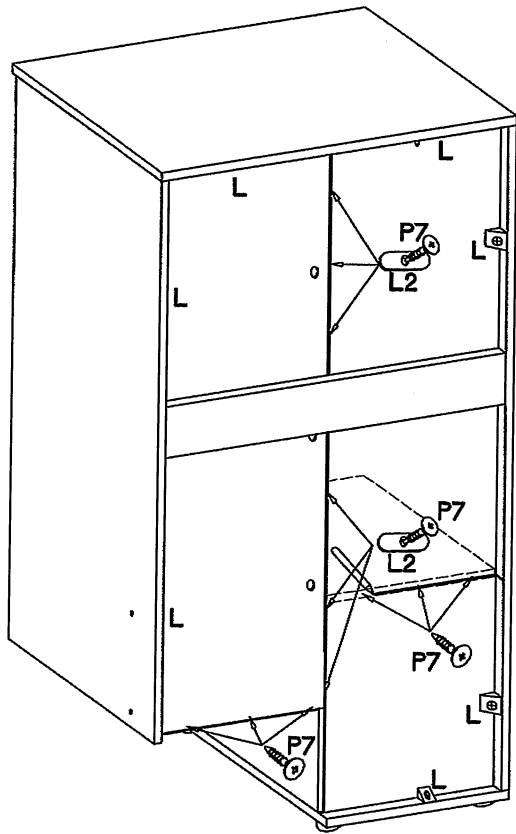

 P7 12	 L2 6	 L 7
--------------	-------------	------------

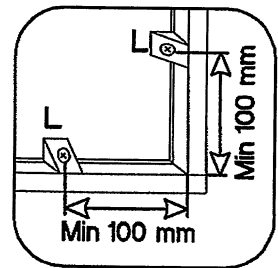
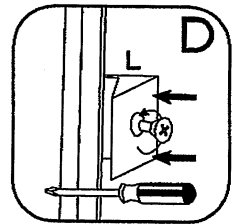
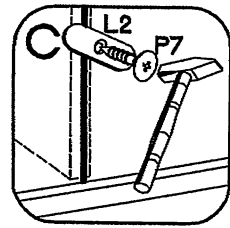



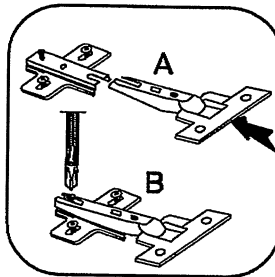
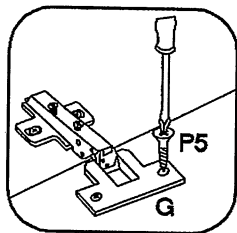

5

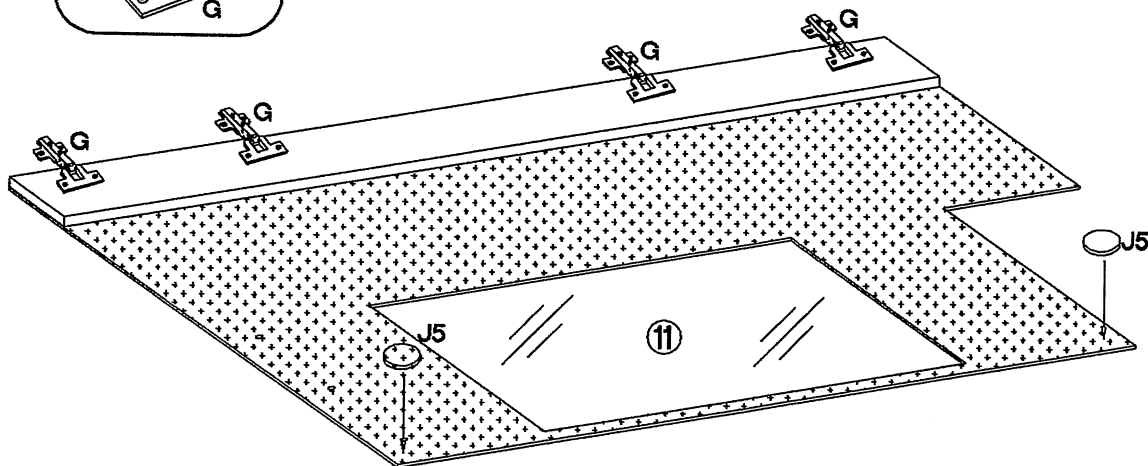

 G 4	 H 4	 P5 8	 J5 2
------------	------------	-------------	-------------



6

 P5 1	 L9 1	 O7 1	 E12 3
--	--	--	---

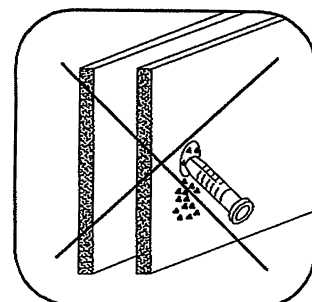
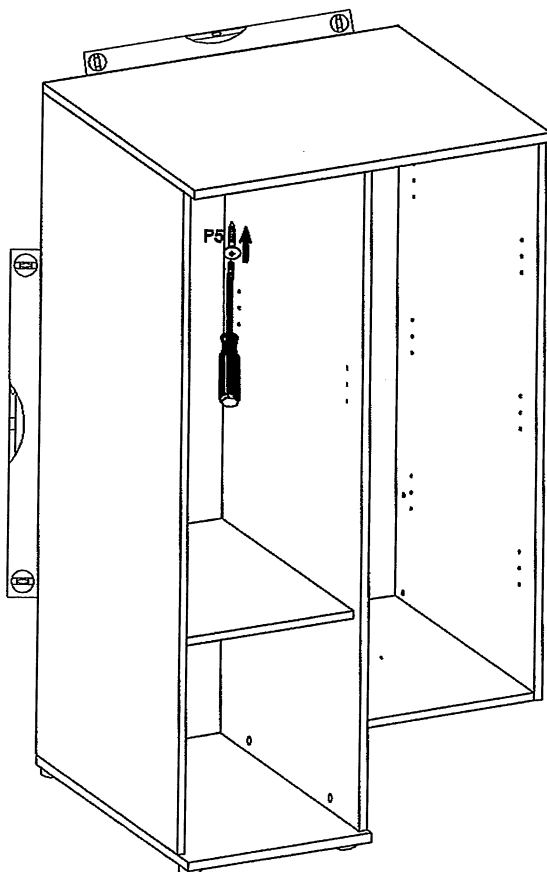
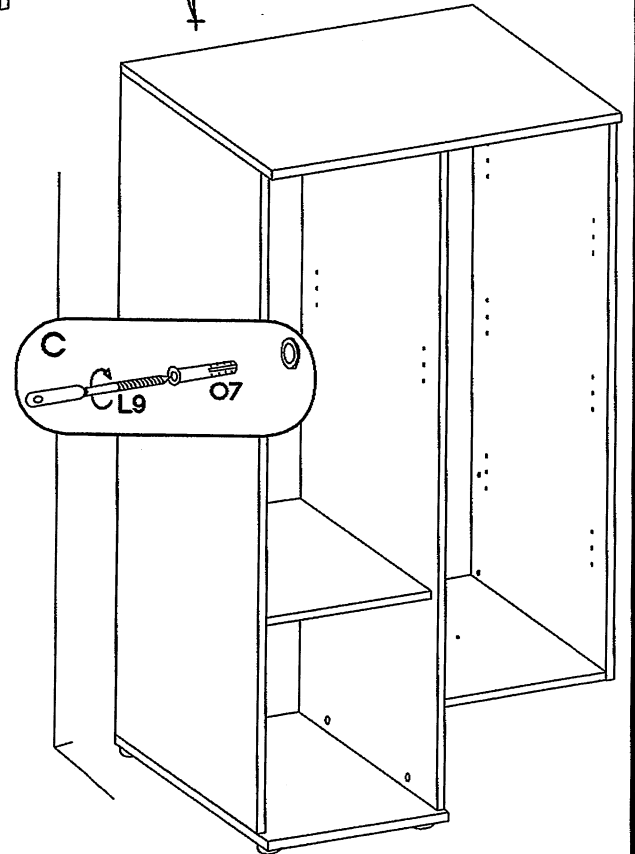
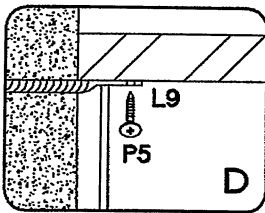
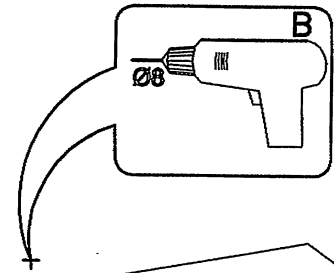
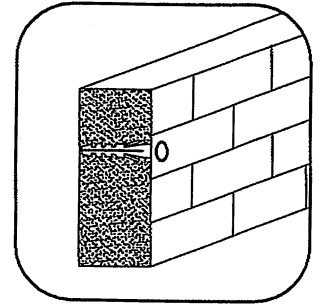
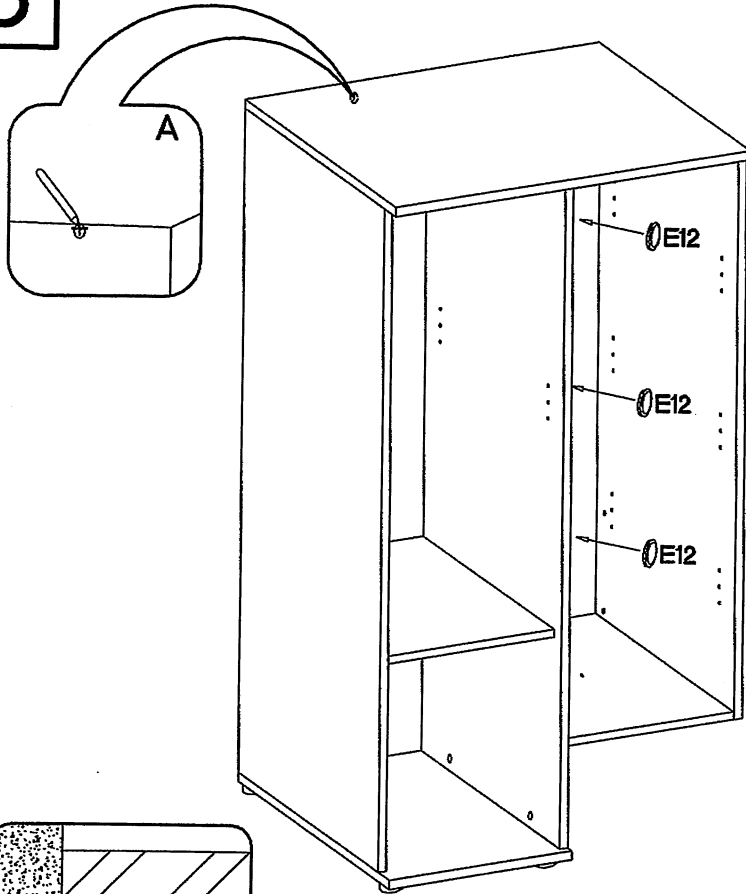





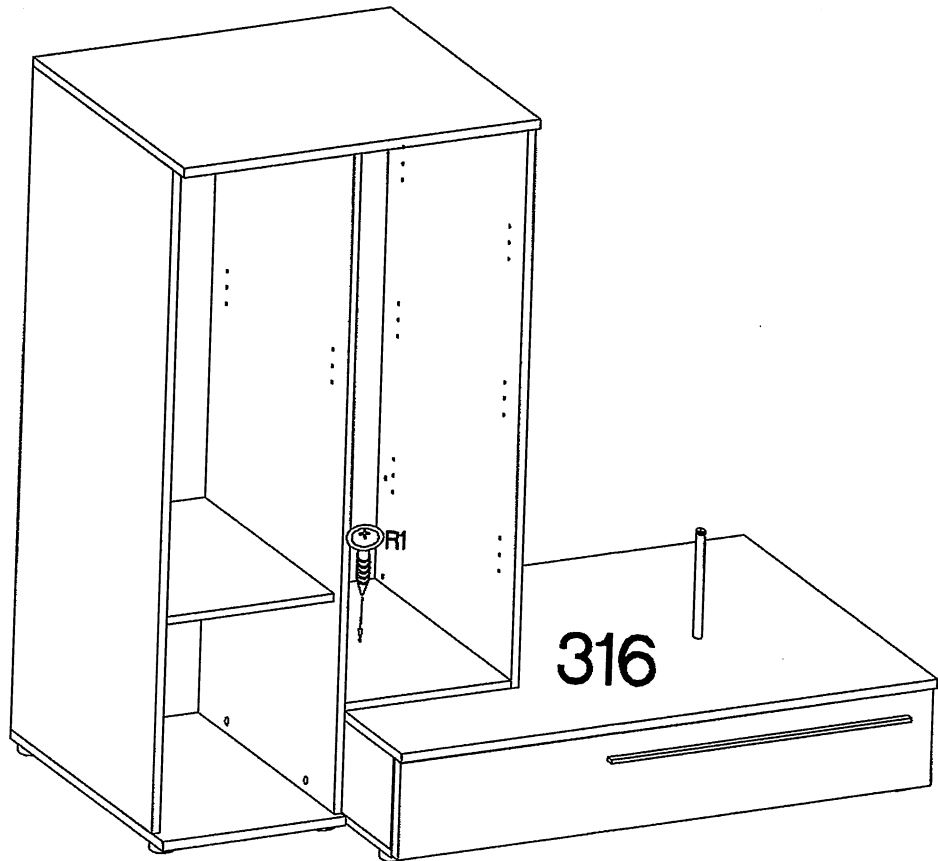
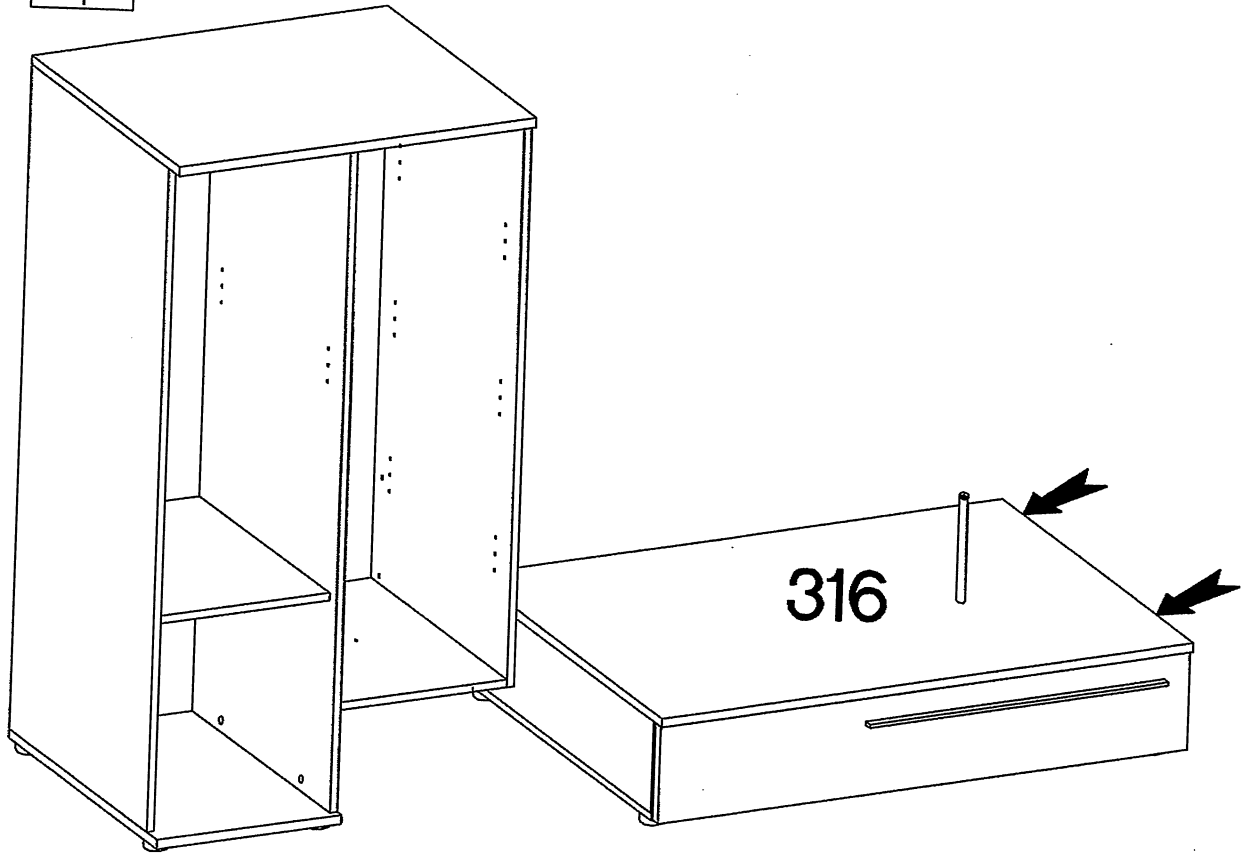

7

4.0x27mm  
R1  
1



8

					
14	12	4	1	3	3

