

RENEE 260

Instrukcija montažu / Assembly instruction / Montage anleitung
Notice de montage / Összeszerelési útmutató / Návod na montáž
Návod k montáži / Instrucțiunile de instalare / Инструкции за инсталпирание

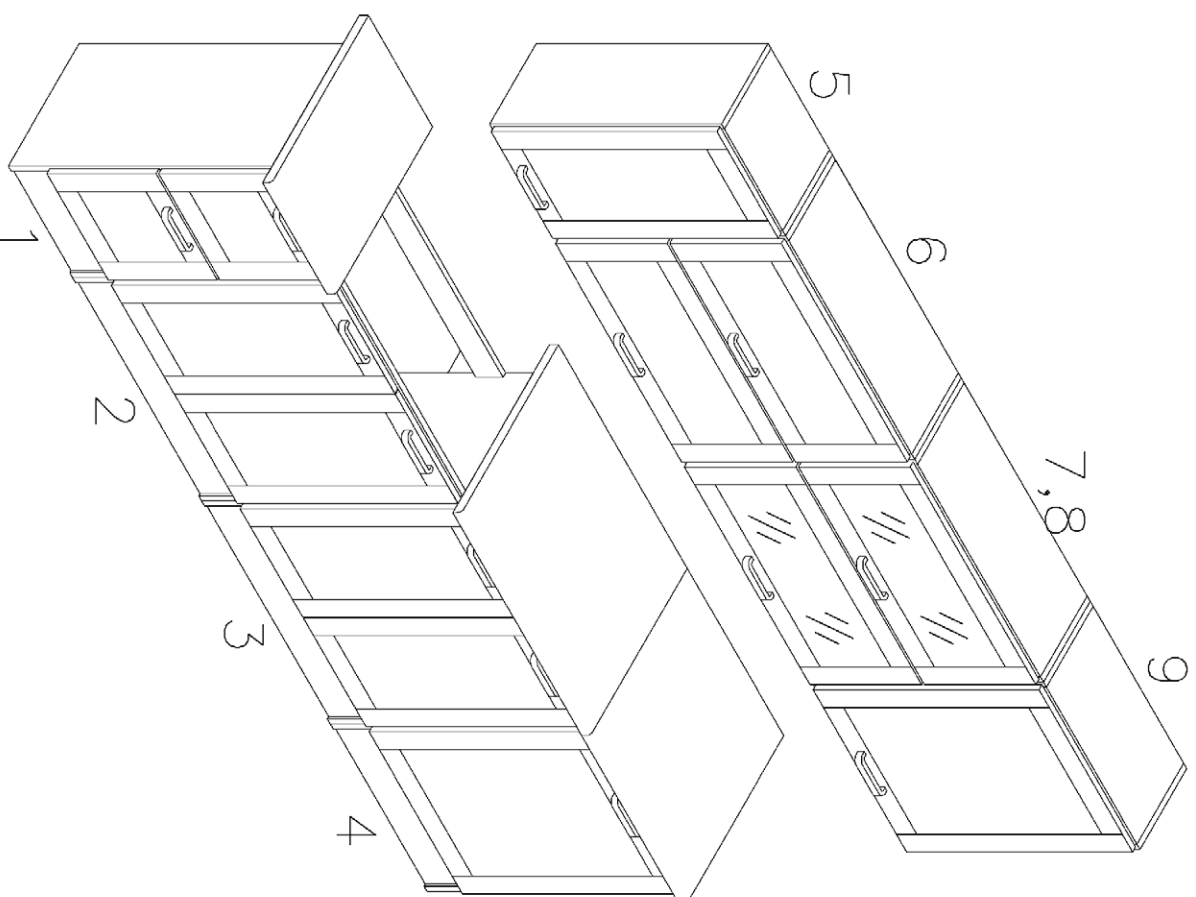

BLACK&WHITE
STYLE

82-310 ELBLAG
NOWINA 38
POLAND

WWW.BWS.COM.PL
TEL. +48(0-55) 648 66 60,
FAX. +48(0-55) 648 66 55



UWAGA!!! Montaż powinien być przeprowadzany przez wykwalifikowaną osobę, ponieważ złe zamontowanie może spowodować zniszczenie mebla lub może wyrządzić szkodę domownikom !!!

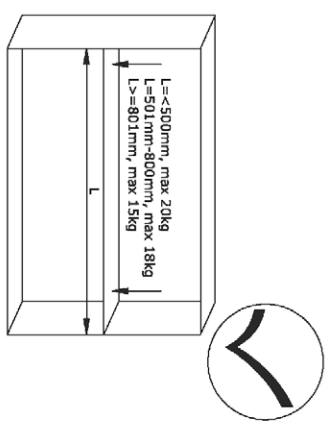
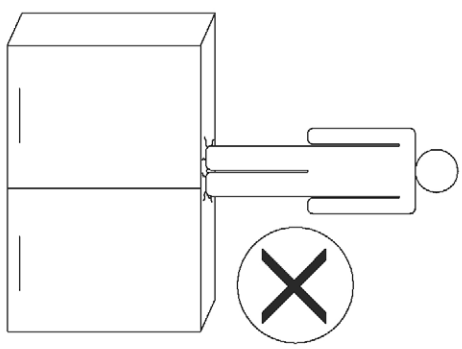
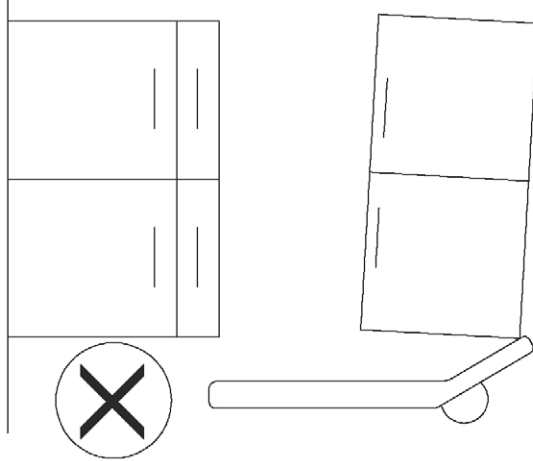
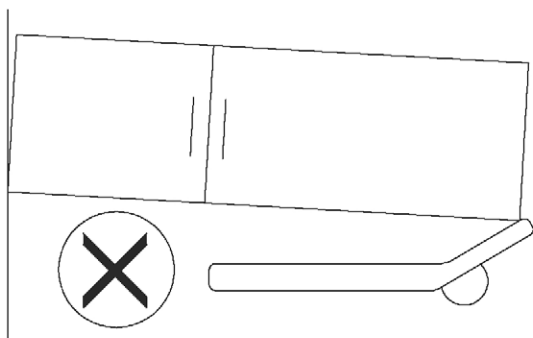
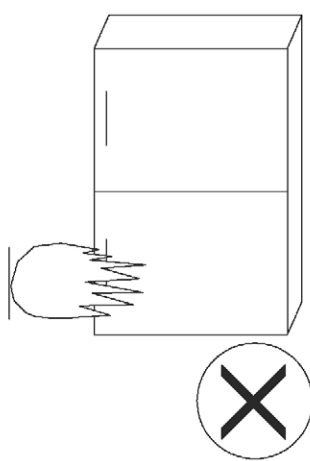
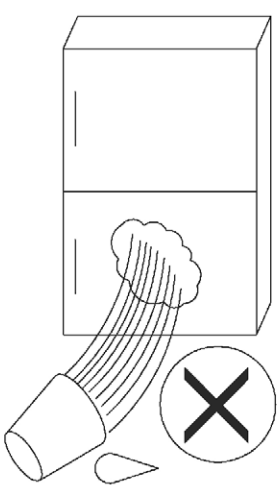
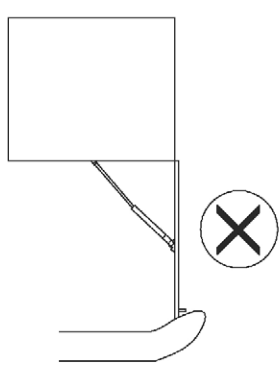
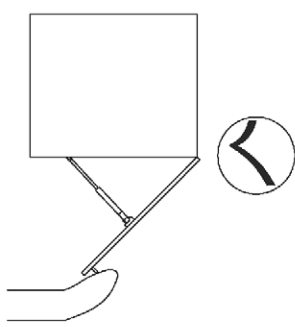
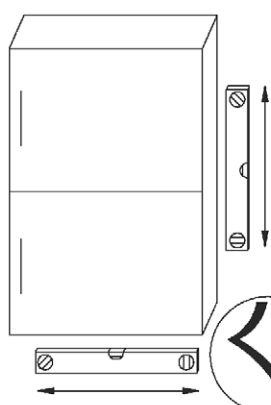
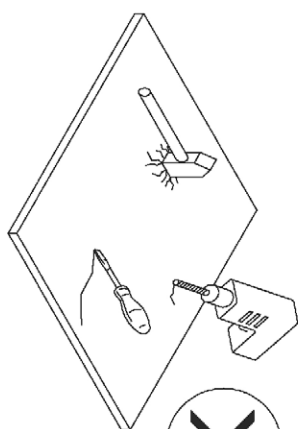
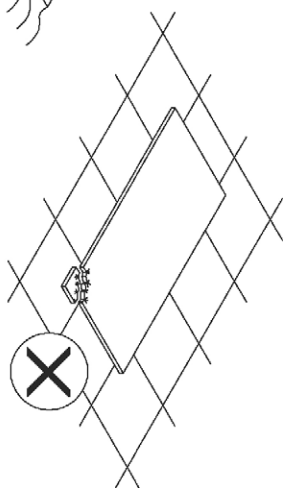
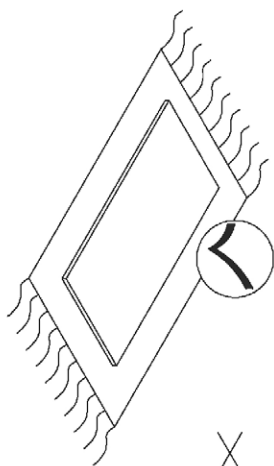

RENEEE 260/1 1/2

Instrukcija montažu / Assembly instruction / Montageanleitung
 Notice de montage / Összeszerelési útmutató / Návod na montáž
 Návod k montáži / Instrucțiunile de instalare / Инструкции за инсталпиране

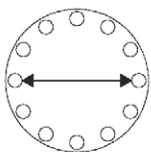
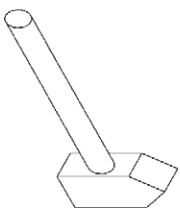
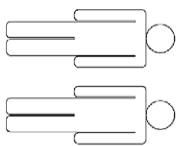



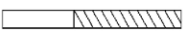



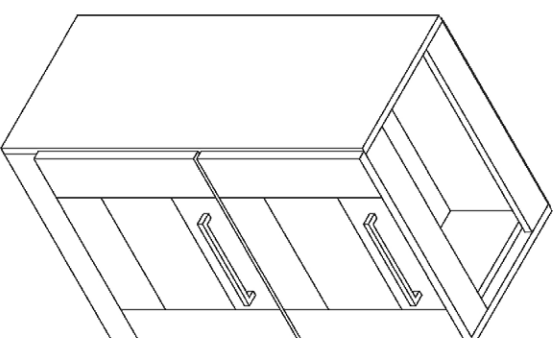
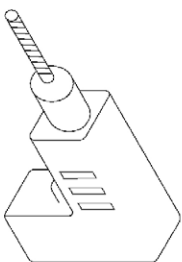





30 mm

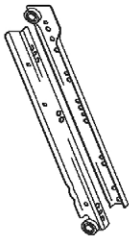

Ø5 mm



A	 X8	B	 X8	C	 X1	D	 X28	G	 X4
H	 X30	I	 X2	K	 X1	M	 X2		
	W1 3,5x13	W2 4x28	W3 4x28						
	 X24	 X2	 X4						

815x440x16

①

815x440x16

②

353x395x16
2x

③

368x440x16

④

384x220x16
4x

⑤

715x395x3

⑨

342x220x16
2x

⑥

368x85x16
2x

⑦

340x405x3
2x

⑧

368x99x16

⑩

RENEEE 260/1 2/2

Instrukcija montažu / Assembly instruction / Montageanleitung
Notice de montage / Összeszerelési útmutató / Návod na montáž
Návod k montáži / Instrucțiunile de instalare / Инструкција за инсталациране

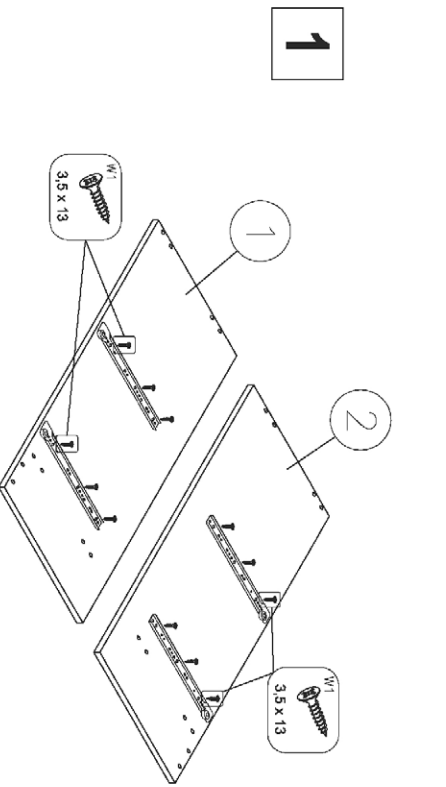

1

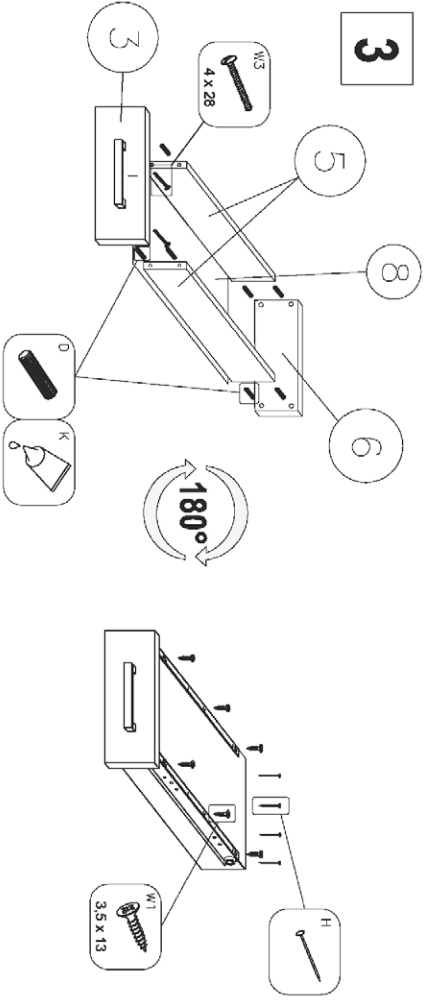

3

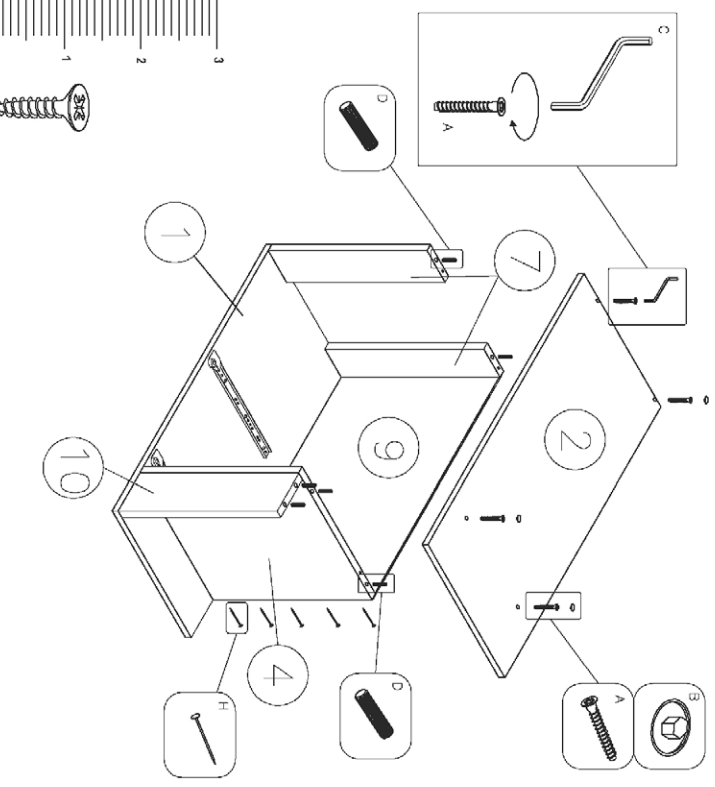

2

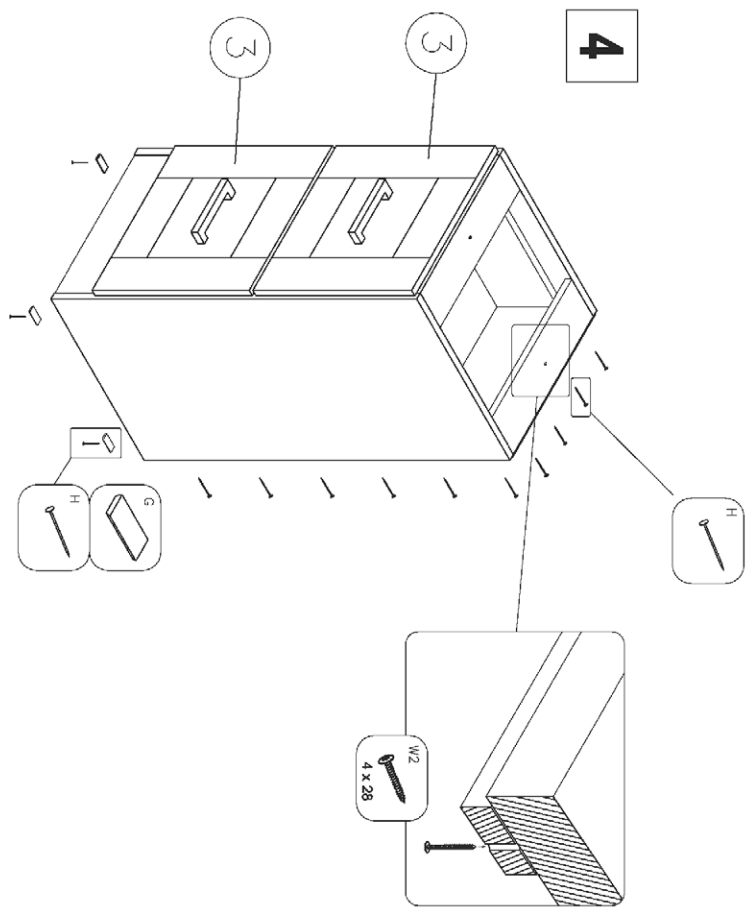

4

RENEEE 260/2 1/2

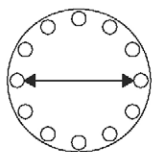
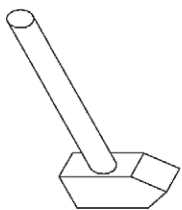
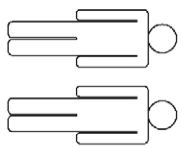



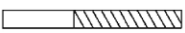



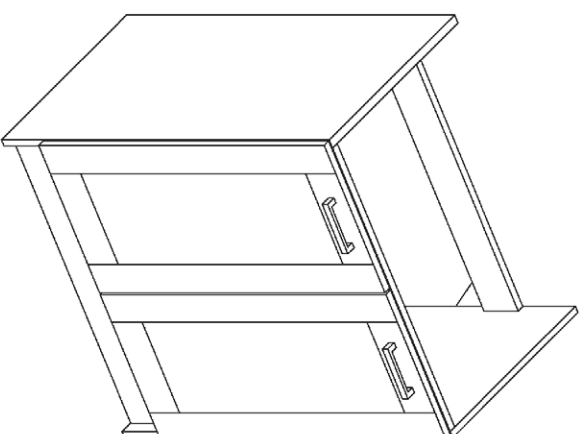
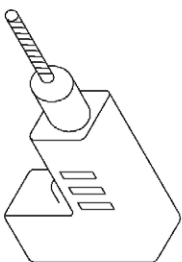



30 min

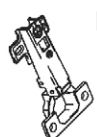

Ø5 mm

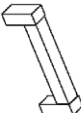

Instrukcija montazu / Assembly instruction / Montageanleitung
 Notice de montage / Összeszerelési útmutató / Návod na montáž
 Návod k montáži / Instrucțiuni de instalare / Инструкции за инсталлиране

A  X8	B  X8	C  X1	D  X12	E  X4
G  X4	H  X16	I  X2	W1 3,5x13  X4	W3 4x28  X4
W4 5x13  X8	W5 6x13  X8			

815x440x16

1

815x440x16

2

713x395x16
2x

3

768x440x16

4

768x85x16 2x

5

768x99x16

6

4x

7

RENEE 260/2 2/2

Instrukcija montazu / Assembly instruction / Montageanleitung
Notice de montage / Összeszerelési útmutató / Návod na montáž
Návod k montáži / Instrucțiunile de instalare / Инструкция за инсталлиране

1

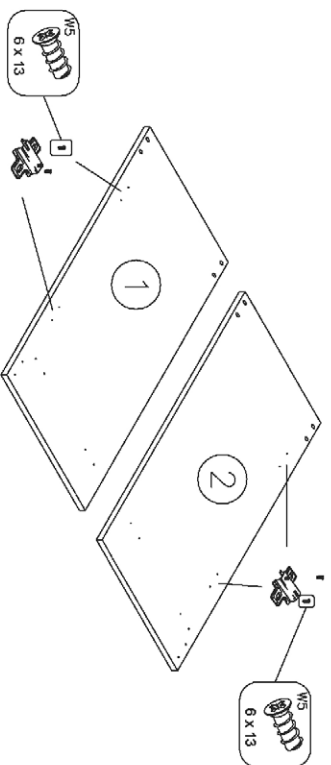

3

2

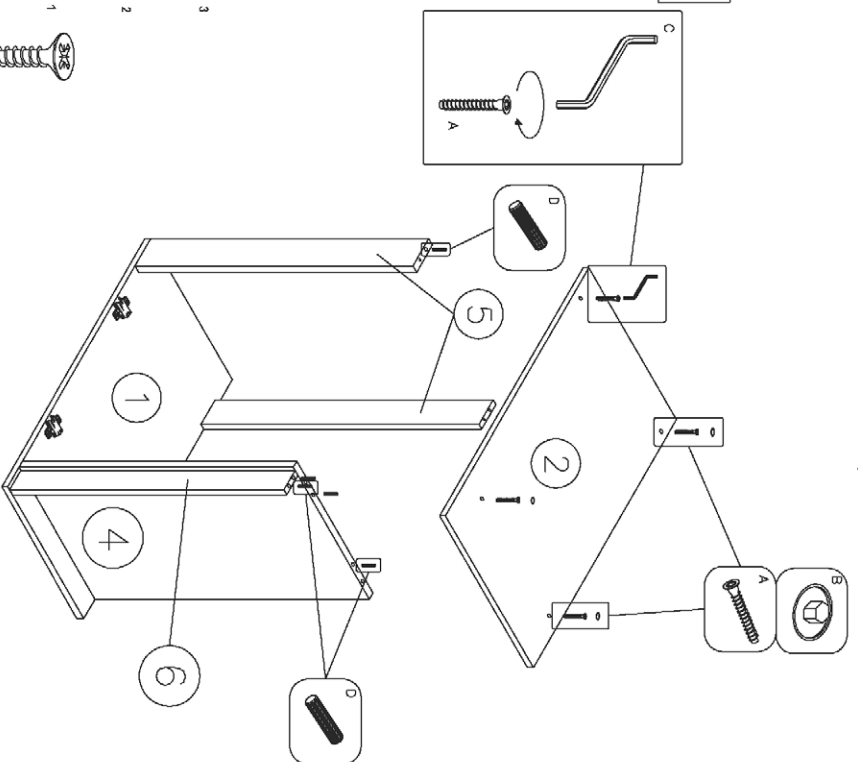

4

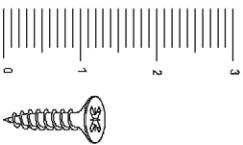
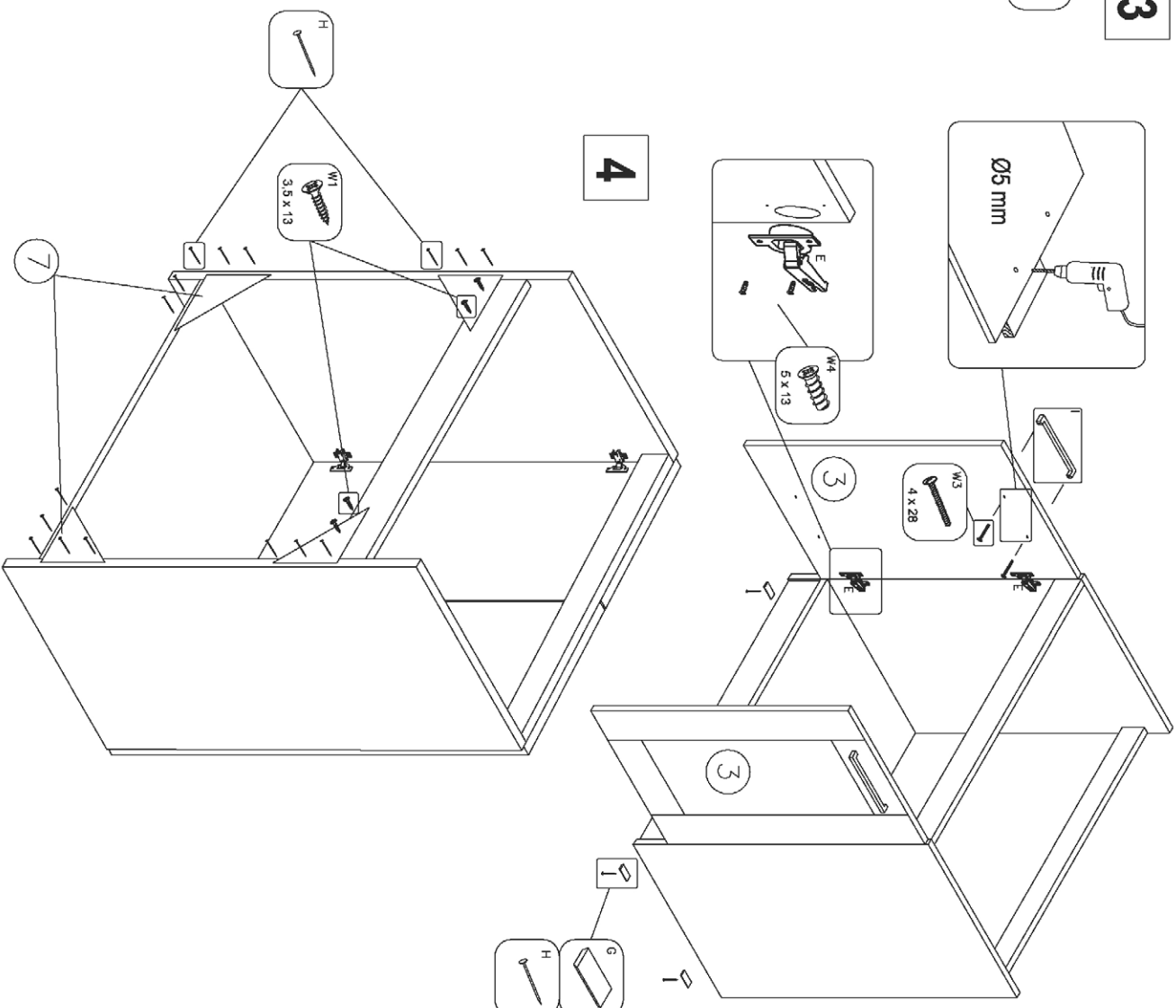

RENEEE 260/3 1/2

Instrukcija montazu / Assembly instruction / Montageanleitung
 Notice de montage / Összeszerelési útmutató / Návod na montáž
 Návod k montáži / Instrucțiunile de instalare / Инструкции за инсталлиране

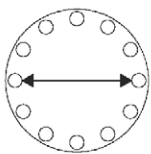
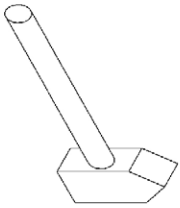
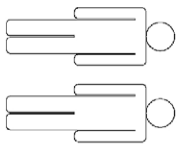



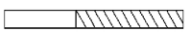



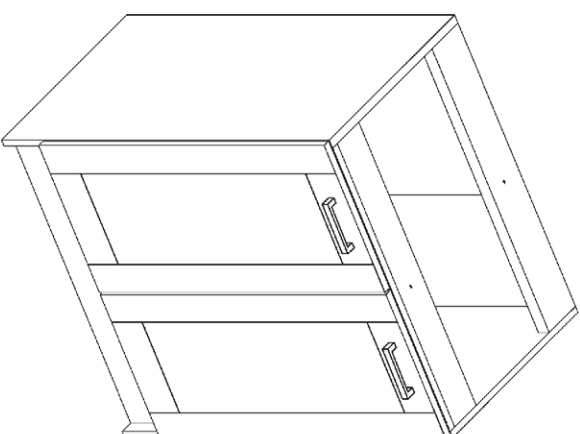
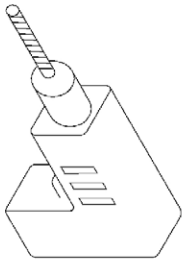



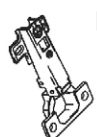

30 min

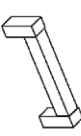

Ø5 mm



A	 X8	B	 X8	C	 X1	D	 X12	E	 X4
G	 X4	H	 X30	I	 X2	L	 X4	LH-678	 X1
W2	 4x28 X2	W3	 4x28 X4	W4	 5x13 X8	W5	 6x13 X8		

815x440x16

①

768x440x16

④

815x440x16

②

768x420x16

⑧

713x395x16
2x

③

768x85x16 2x

⑤

768x99x16

⑥

715x395x3
2x

⑦

RENEEE 260/4 1/2

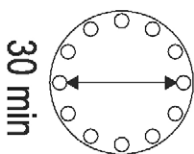
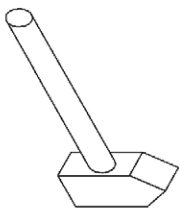
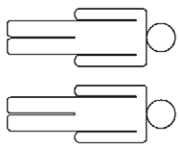



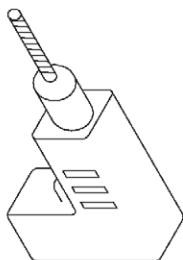



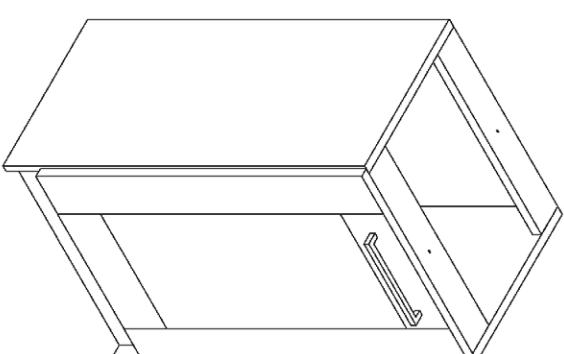



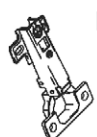

Ø5 mm

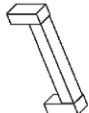

Instrukcija montazu / Assembly instruction / Montageanleitung
 Notice de montage / Összeszerelési útmutató / Návod na montáž
 Návod k montáži / Instrucțiuni de instalare / Инструкција за инсталациране



A	 X8	B	 X8	C	 X1	D	 X12	E	 X2
G	 X4	H	 X20	I	 X1	L	 X4	W2	 X2
W3	 X2	W4	 X4	W5	 X4			W2	 X2
								4x28	

815x440x16

1

815x440x16

2

713x595x16

3

715x595x3

4

568x440x16

5

568x420x16

6

568x85x16

2x

7

568x99x16

8

RENEEE 260/4 2/2

Instrukcija montazu / Assembly instruction / Montageanleitung
Notice de montage / Összeszerelési útmutató / Návod na montáž
Návod k montáži / Instrucțiunile de instalare / Инструкция за инсталлиране

1

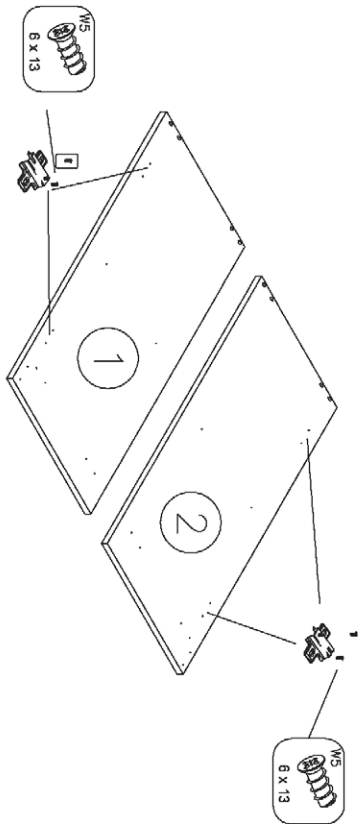

3

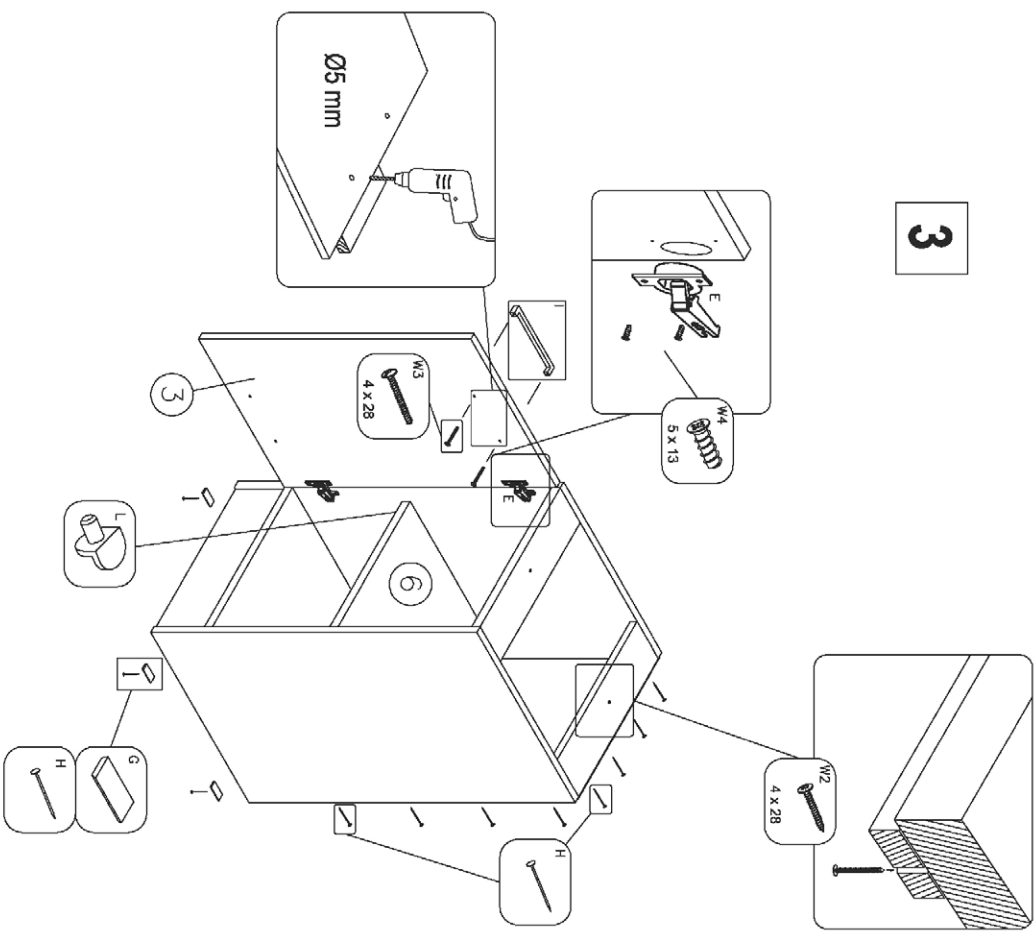

2

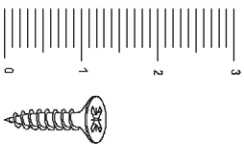
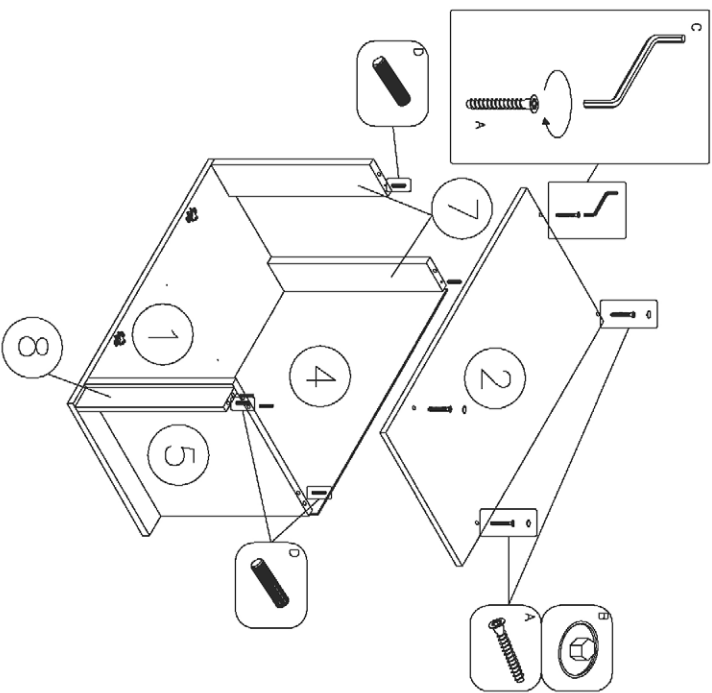

RENEEE 260/5 1/2

Instrukcija montazu / Assembly instruction / Montageanleitung
 Notice de montage / Összeszerelési útmutató / Návod na montáž
 Návod k montáži / Instrucțiunile de instalare / Инструкции за инсталлиране

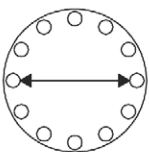
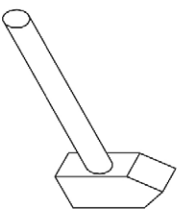
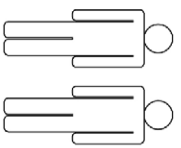



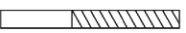



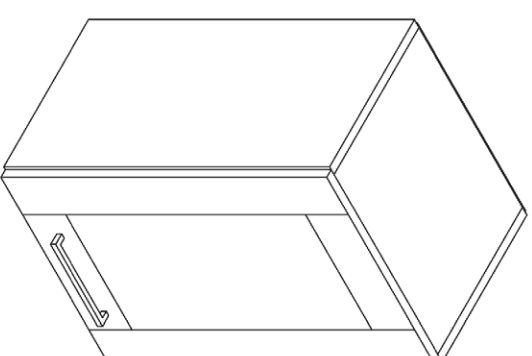
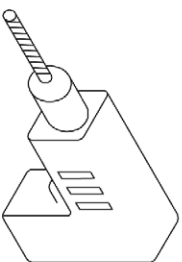





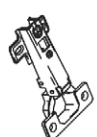

30 min

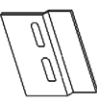

Ø5 mm



A	 X8	B	 X8	C	 X1	D	 X8	E	 X2
H	 X20	I	 X1	L	 X8	O	 X2	W2	 X4
W3	4X28	W4	5X13	W5	6X13	M	 X2	4X30	 X4
	 X2	 X4	 X4						

720x290x16

1

720x290x16

2

713x395x18

3

368x290x16
2x

4

715x395x3

6

368x260x16
2x

5

RENEEE 260/5 2/2

Instrukcija montazu / Assembly instruction / Montageanleitung
Notice de montage / Összeszerelési útmutató / Návod na montáž
Návod k montáži / Instrucțiuni de instalare / Инструкция за инсталлиране

1

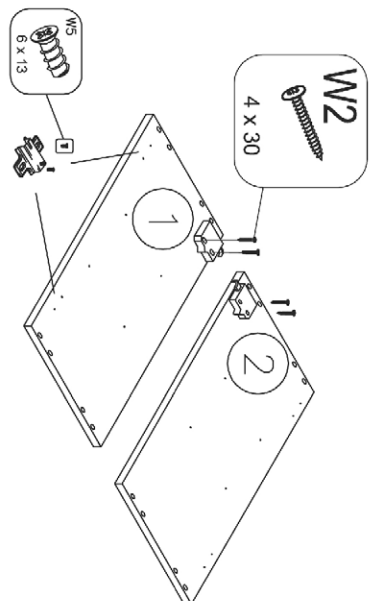

2

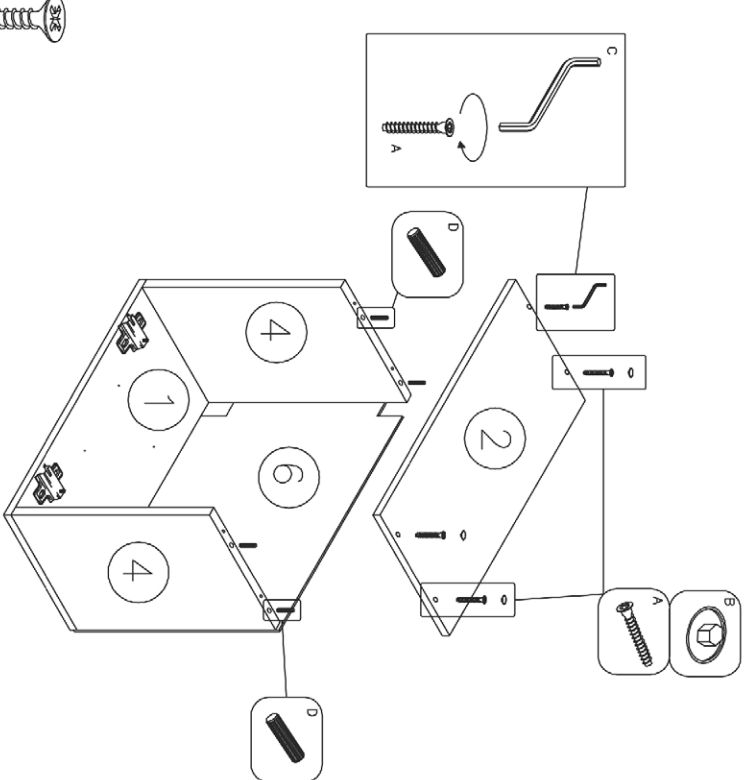

3

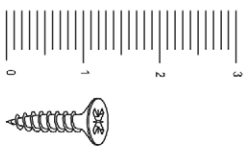
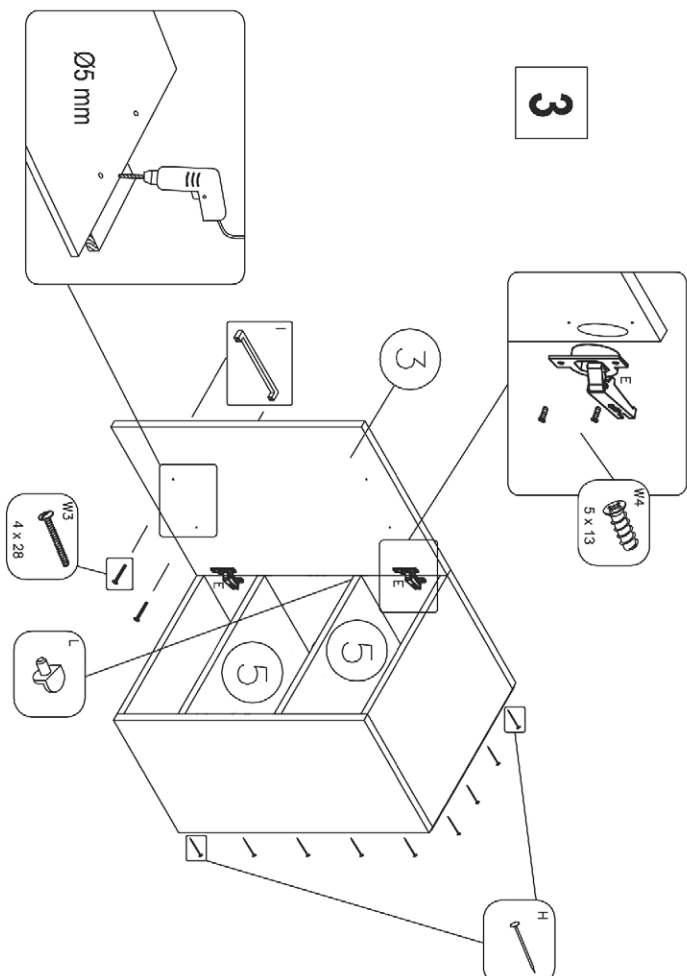

RENEEE 260/6 1/2

Instrukcija montazu / Assembly instruction / Montageanleitung
 Notice de montage / Összeszerelési útmutató / Návod na montáž
 Návod k montáži / Instrucțiunile de instalare / Инструкции за инсталлиране

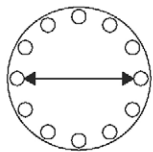
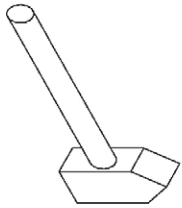
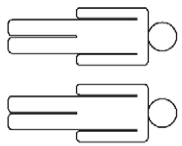



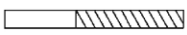



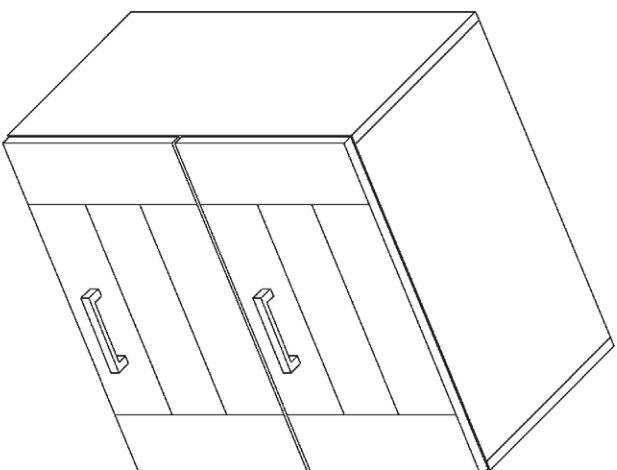
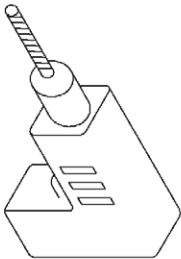





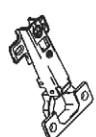
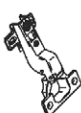

30 mm

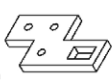

Ø5 mm



A	B	C	D	E
 X12	 X12	 X1	 X12	 X2
 X2	 X30	 X2	 X8	 X2
 X2	 4X28 X6	 4X28 X4	 5X13 X8	 6X13 X8

720x290x16

1

720x290x16

2

795x353x16
2x

3

768x260x16
2x

6

768x290x16
3x

4

795x355x3
2x

5

RENEEE 260/7,8 1/3

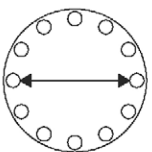
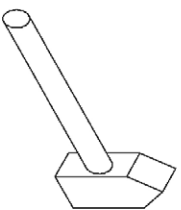
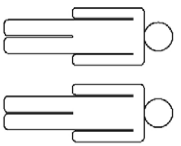



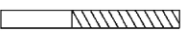



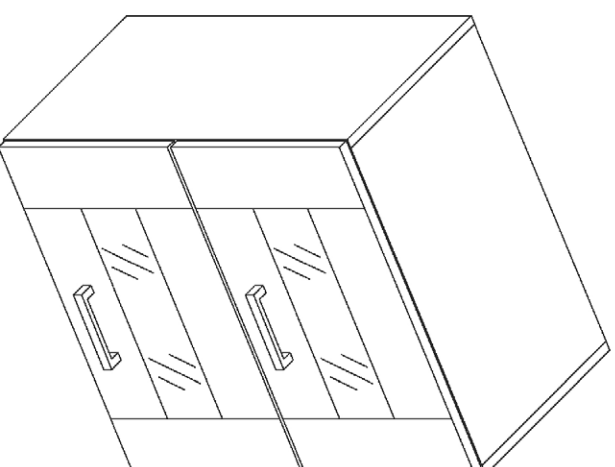
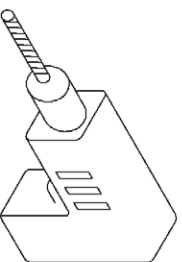





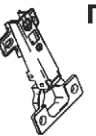

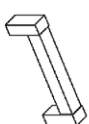

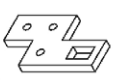
30 min









Ø5 mm



A	B	C	D	E
 X12	 X12	 X1	 X12	 X2
 X2	 X30	 X2	 X8	 X2
 X2	 X20	 X20	 X6	 X4
 X8	 X8			

Instrukcija montazu / Assembly instruction / Montageanleitung
 Notice de montage / Összeszerelési útmutató / Návod na montáž
 Návod k montáži / Instrucțiunile de instalare / Инструкции за инсталпирание

 1	 2	 3
720x290x16	720x290x16	795x353x16 2x
 4	 5	 6
768x290x16 3x	795x355x3 2x	768x260x16 2x

RENEEE 260/7,8 3/3

Instrukcija montazu / Assembly instruction / Montageanleitung
Notice de montage / Összeszerelési útmutató / Návod na montáž
Návod k montáži / Instrucțiunile de instalare / Инструкции за инсталлиране

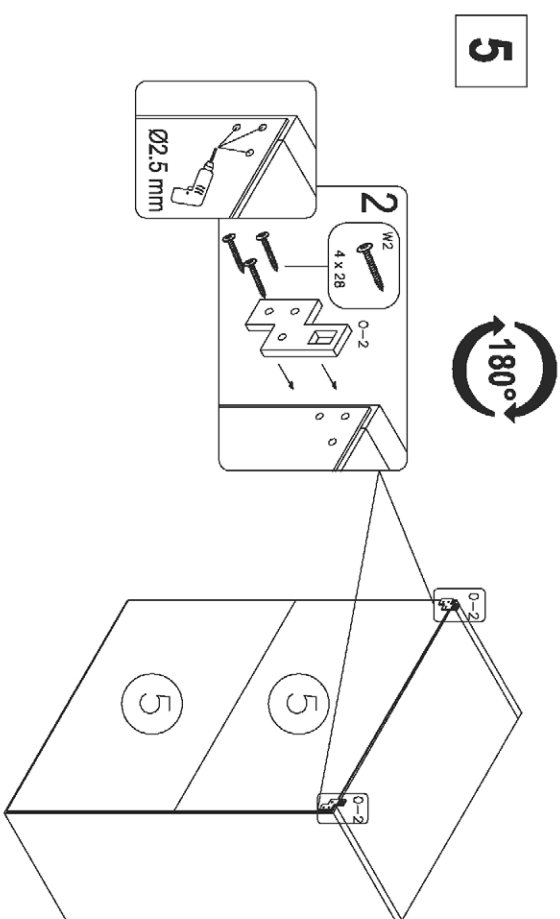
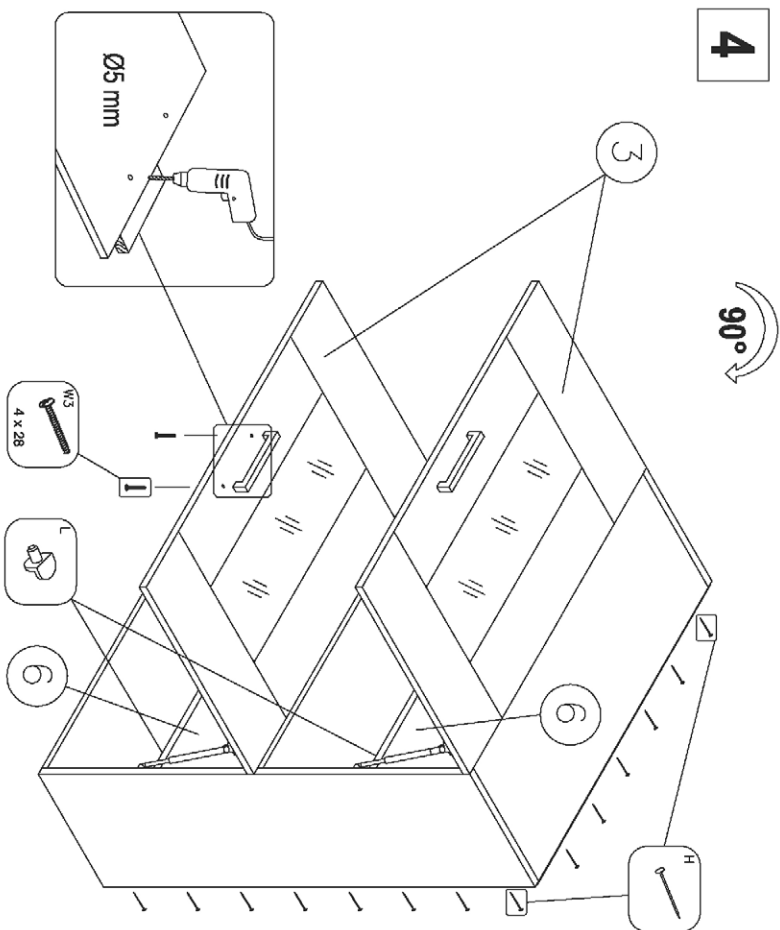

RENEEE 260/9 1/2

Instrukcija montazu / Assembly instruction / Montageanleitung
 Notice de montage / Összeszerelési útmutató / Návod na montáž
 Návod k montáži / Instrucțiunile de instalare / Инструкция за инсталлиране

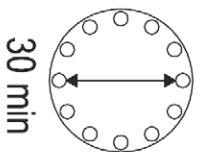
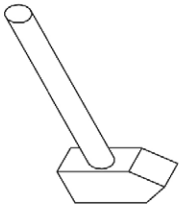
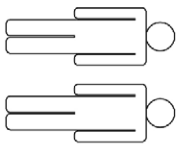







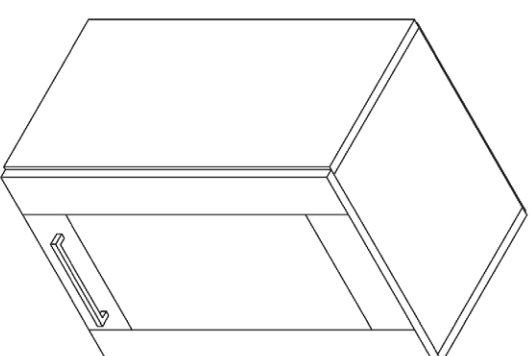
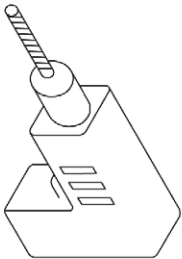





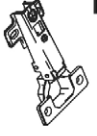

30 min



Ø5 mm

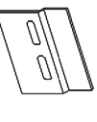

A	 X8	B	 X8	C	 X1	D	 X8	E	 X2
H	 X20	I	 X1	L	 X8	O	 X2	W2	 4X30
W3	 4X28	W4	 5X13	W5	 6X13	M	 X2	W2	 4X30
	X2		X4		X4		X2		X4

720x290x16

1

720x290x16

2

713x595x18

3

568x290x16

4

2x

715x595x3

6

568x260x16

5

2x

RENEE 260/9 2/2

Instrukcija montažu / Assembly instruction / Montageanleitung
Notice de montage / Összeszerelési útmutató / Návod na montáž
Návod k montáži / Instrucțiunile de instalare / Инструкция за инсталлиране

1

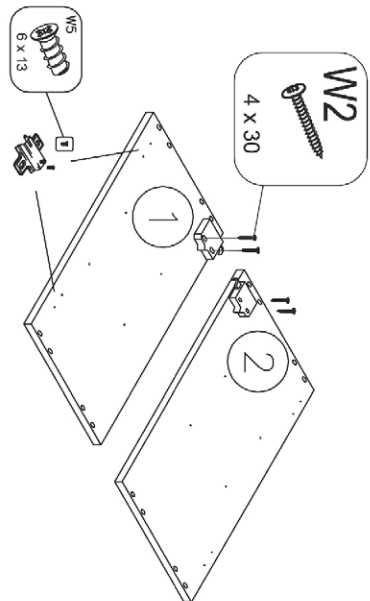

2

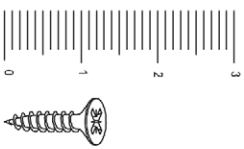
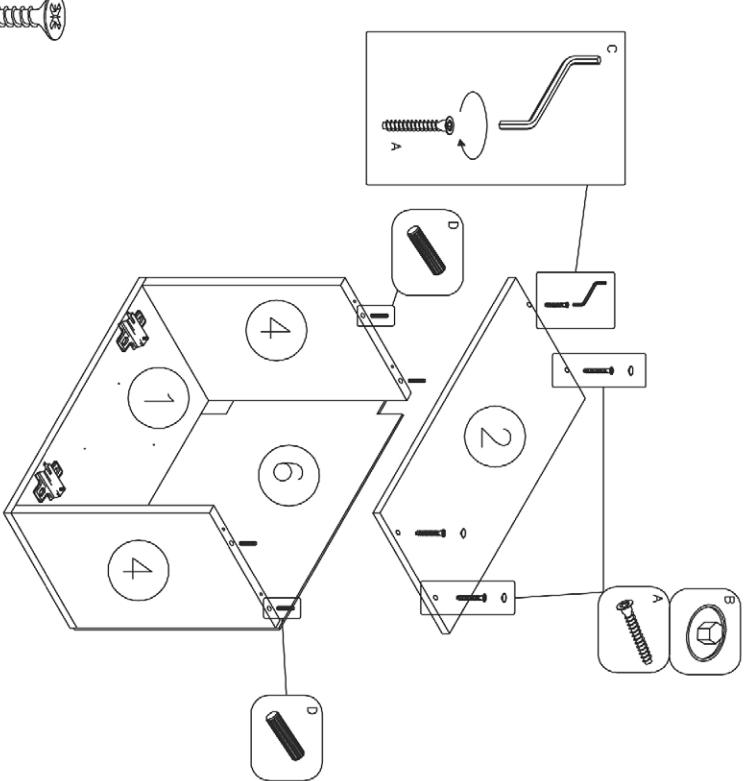

3

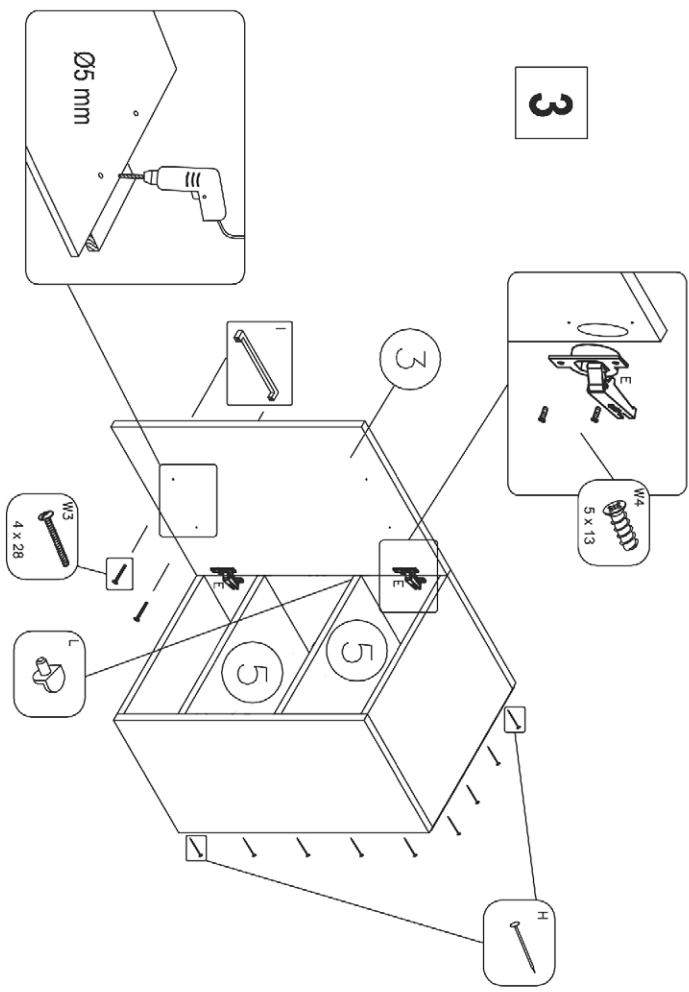

RENEEE 260

Instrukcija montazu / Assembly instruction / Montageanleitung
Notice de montage / Összeszerelési útmutató / Návod na montáž
Návod k montáži / Instrucțiuni de instalare / Инструкцији за инсталациране

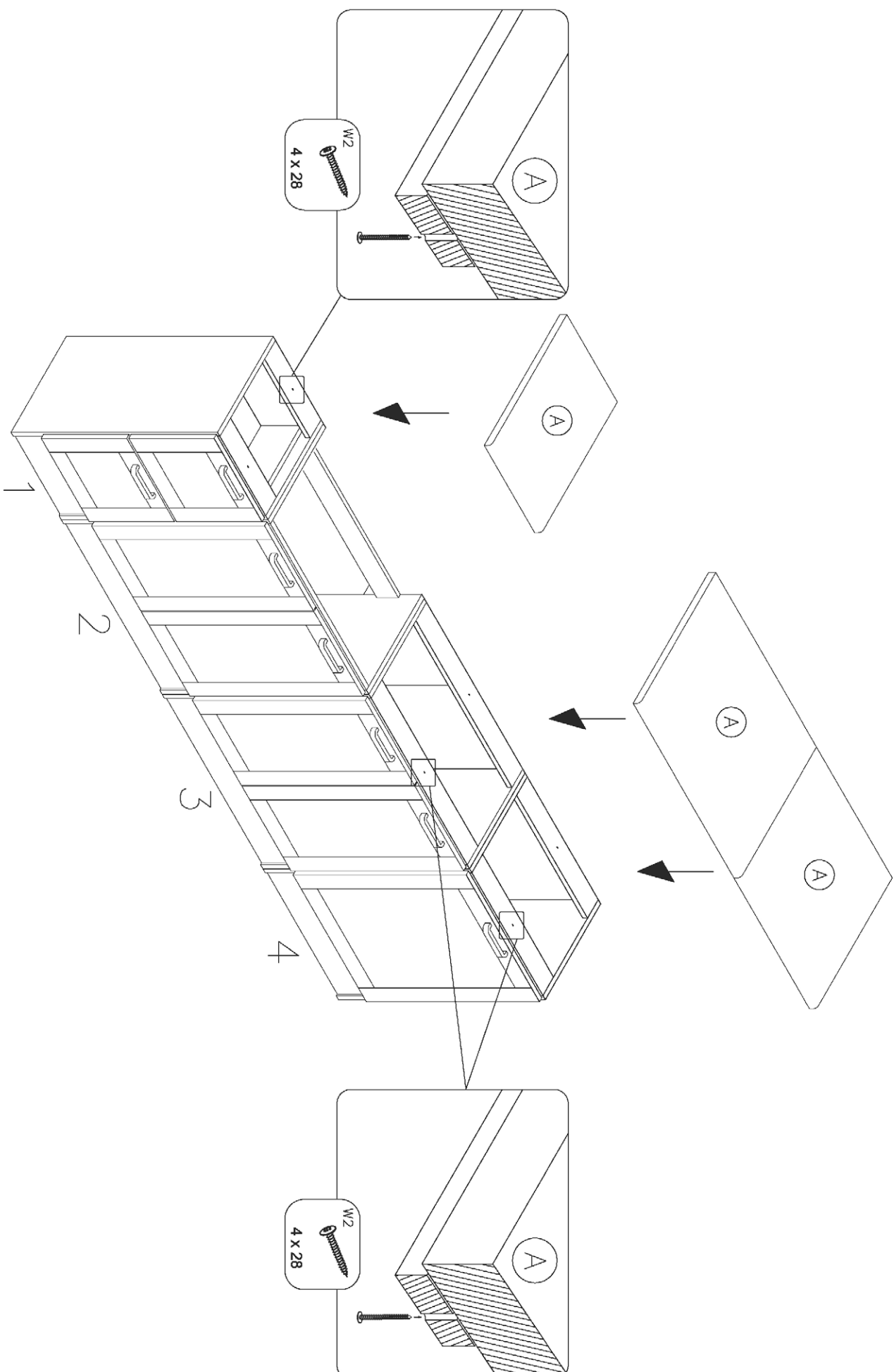

WARUNKI GWARANCJI:

PL

1. Producent udziela 12 miesięcznej gwarancji od daty wydania mebli kupującemu.
 2. Sposób i miejsce udziela gwarant. Usunięcie usterek następuje w fabryce wyjątkowo, tylko wówczas, gdy naprawa nie jest możliwa w domu kupującego. O ile Kupujący odmówi naprawy w domu wówczas w całości pokryje koszty transportu mebli.
 3. Producent zapewnia dobrą jakość i właściwe funkcjonowanie mebla przy zachowaniu prawidłowych zasad użytkowania zgodnie z przeznaczaniem w okresie 12 miesięcy od daty sprzedaży (data wydania), zasad użytkowania zgodnie z przeznaczaniem w okresie 12 miesięcy od daty sprzedaży (data wydania).
 4. Przy sprzedaży celem sprawdzenia jakości, meble powinny być rozpakowane przez sprzedawcę, okazane kupującemu przy wydaniu na sklepie, w celu udowodnienia zgodności towaru z umową.
 5. Przy odbiorze zakupionych mebli prosimy o sprawdzenie stanu elementów szklanych (nie sprawdzone uszkodzone elementy szklane nie podlegają gwarancji!).
 6. Gdy niezgodność towaru stwierdzono przed upływem sześciu miesięcy, ustawa o sp. kons. domniemuje, że istniała ona w chwili wydania towaru. Wówczas to na sprzedawcy ciąży obowiązek ewentualnego wykazania, że było inaczej, że towar konsumpcyjny był zgodny z umową w momencie wydania.
 7. Na meble dostarczone do obrotu w paczkach przeznaczonych do montażu poza miejscem wydania (o ile paczka nie nosi śladów uszkodzenia) czas zgłoszenia reklamacji na widoczne (jawne) wady wykonania oraz braki elementów (akcesoriów) wynosi 7 dni od daty zakupu.
 8. Reklamacje dotyczące braków i uszkodzeń mebli wydanych kupującemu jak w pkt.6 zakłada sprzedawca, natomiast reklamacje na wady objęte gwarancją sprzedawca niezwłocznie przekazuje do producenta (gwaranta).
 9. Niezgodność towaru z umową powinna być zgłoszona w ciągu 1 miesiąca od momentu jej zauważenia do punktu zakupu mebli.
 10. Sprzedawca przed zgłoszeniem reklamacji gwarantowi powinien we własnym zakresie dokonać oględzin towaru niezgodnego z umową. Wymagane jest pisemne zgłoszenie reklamacji (liczy się data stempla pocztowego oraz potwierdzenie daty z nadania faksu).
 11. W przypadku gdy sprzedawca nie załatwi reklamacji natychmiast jest zobowiązany potwierdzić jej przyjęcie na piśmie.
 12. Gwarant w terminie 14 dni od dnia przyjęcia zgłoszenia reklamacyjnego zawiadomi kupującego, że złożona reklamacja jest lub nie jest zasadna, lub zgłosi się do kupującego w celu oględzin i ewentualnego ustalenia sposobu i terminu załatwienia reklamacji.
 13. W przypadku nieuwzględnionego zgłoszenia reklamacji kupujący zobowiązany jest do pokrycia kosztów poniesionych w związku z przyjęciem serwisu.
 14. Odebranie karty gwarancyjnej przez kupującego przy zakupie mebli jest równoznaczne z dokonaniem odbioru ilościowego i jakościowego i nie stwierdzeniem uszkodzeń lub braków zewnętrznych.
- Kupujący, którego reklamacja jest zasadna może domagać się:
15. Aby sprzedawca usunął wady mebla, lub dostarczyć meble wolne od wad (art. 577 § 1 KC).
 16. Kupujący ma możliwość skorzystania z wymiany towaru na nowy, wolny od wad po wcześniejszym przeprowadzeniu czterech islotnych i udokumentowanych napraw mebla (po wymianie towaru na nowy, termin gwarancji nie będzie biegł od nowa)
 17. W przypadku, gdy wada jest nieusuwalna lub jej usunięcie spowodowałoby obniżenie jakości mebla, załatwienie reklamacji może nastąpić za zgodą kupującego przez obniżenie ceny mebla.
- Gwarancją producenta nie są objęte:
- wady, uszkodzenia widoczne przy zakupie,
 - uszkodzenia powstałe w wyniku niewłaściwego przewozu bądź przenoszenia mebli, oraz złego montażu
 - uszkodzenia powstałe w wyniku niewłaściwego użytkowania, przechowywania i konserwacji, jak również wynikiem po sprzedaży ze zdarzeń losowych i innych okoliczności,
 - uszkodzenia powstałe w wyniku niewłaściwego użytkowania, przechowywania i konserwacji, jak również po stwierdzeniu napraw przez osobę nie upoważnioną przez firmę producenta,
 - wady i uszkodzenia w następstwie których obniżono cenę wyrobu przy jego zakupie,
 - szkody i usterek spowodowane przez zwierzęta.

POLSKI

Montaż powinien być przeprowadzany przez wykwalifikowaną osobę, ponieważ złe zamontowanie może spowodować zniszczenie mebla lub może wyznaczyć szkodę domownikom.

ENGLISH

Assembly should be carried out by a qualified person, because wrong assembly may lead to that the furniture will topple over and cause Injury or damage.

DEUTSCH

Fachkundige Montage erforderlich. Unsachgemäße Montage kann zu Unfällen führen.

FRANÇAIS

Le montage doit être effectué par une personne compétente. Un montage mal effectué peut provoquer la chute du meuble et blesser quelqu'un.

MAGYAR

Az összeszerelést ajánlatos képzett szakemberre bízni, mert a helytelen összeszerelés következtében a bútor felborulhat és sérülést okozhat.

ČESKY

Montáž by měla být provedena kvalifikovanou osobou - nesprávné provedení může vést k převrtnutí nábytku a způsobit úraz nebo destruktci.

SLOVENSKY

Montáž by mala byť prevedena kvalifikovanou osobou. Pri nesprávnej montáži môže dôjsť k padu nábytku, a tým aj k prípadnému úrazu.

ROMANA

Se recomandă ca montarea să fie realizată de o persoană calificată; asamblarea greșită poate determina desprinderea mobilierului, deteriorarea lui și chiar producerea de accidente.

БЪЛГАРСКИ

Монтажът трябва да бъде извършен от квалифицирано лице, тъй като неправилният монтаж може да увреди част от обзавеждането, или може да доведе до увреждане на домакинство

WARRANTY TERMS AND CONDITIONS:

EN

- The furniture is covered with 12-months producer's warranty from the date of transferring the furniture to the purchaser.
- The way and place is set by guarantor. Defects may be removed in a factory only in exceptional cases, if a repair is not possible at purchaser's place. In case the purchaser refuses the repair at their place, the purchaser shall bear the costs of furniture transport.
- The Producer warrants good quality and proper functioning of furniture provided that furniture is used properly, in a way compliant with furniture's intended use, within a period of 12 months from the date of sale. (date of furniture takeover).
- Upon the sale, in order to check the quality, a seller shall unpack the furniture, present them to the purchaser upon furniture's transfer in a shop to ensure the goods are compliant with the order.
- Upon taking over the furniture, the purchaser shall check the condition of all glass elements (elements not checked, and damaged are excluded from the warranty).
- In case the furniture was found defective before the expiration of 6-month period from the purchase date, the special conditions of consumer sale and the amendment of civil code act dated 27.07.2002, presumes that the defect was present in the moment of goods takeover. In this case the seller is obliged to prove otherwise, and the consumption goods were compliant with the order in the moment of the goods' takeover.
- Furniture delivered in packs intended for assembly outside the place of furniture transfer (provided that a package has not been damaged) the time for lodging a complaint for visible manufacturing defects and missing elements (accessories) is 7 days from the purchase date.
- Complaints on shortages and damages of furniture given to the purchaser as stipulated in item 7 shall be settled by the producer, whereas the complaints on defects covered with warranty, the seller is obliged to send the goods to the producer (guarantor) without undue delay.
- The discrepancy of goods with the order shall be reported to the seller within 1 month from the moment of noticing the discrepancy.
- The seller, before lodging the complaint to the guarantor shall examine the discrepant goods on their own. It is necessary to lodge the complaint in writing (date as postmarked is decisive and/or fax confirmation report date).
- In case the seller does not settle the complaint immediately, the receipt of the complaint shall be confirmed in writing.
- The guarantor shall inform the purchaser whether the complaint is or is not justified within 14 days from the date of lodging a complaint, or that it is necessary to perform further examination and possibly, to agree the way and time for the complaint settlement.
- In case the complaint was groundless, the purchaser is obliged to cover the costs of technical service's arrival.
- Accepting the warranty card by the purchaser while buying the furniture is equivalent to quantity and quality approval and not founding any damages or external shortages.

The purchaser, whose complaint is justified, may demand:

- The seller to remove the furniture defects, or deliver furniture free of defects (art. 577 § 1 Civil Code).
- The purchaser has an option to replace the goods with brand new, free of defects, if previously four material and documented repairs were performed (after the goods are replaced with brand new ones, the warranty term runs anew).
- In case, the defects cannot be removed or its removal would result in deteriorating the value of the furniture, the complaint may be settled through the reduction of the furniture's price, with the purchaser's consent.

The producer's warranty does not cover:

- defects, damages visible on the date of purchase,
- damages that occur as a result of improper use, storage and maintenance as well as repairs performed by unauthorized person was found
- defects and damages in the result of which the price of product was reduced in the moment of purchase,
- damages and defects caused by animals.

BEDINGUNGEN DER GARANTIE:

DE

- Der Hersteller gewährt eine 12-monatige Garantie ab der Datum der Auslieferung der Möbel dem Käufer.
- Die Art und Weise, sowie der Ort werden von dem Garantiegeber festgestellt. Die Beseitigung der Fehler findet in der Fabrik nur ausnahmsweise statt, ausschließlich wenn die Reparatur in dem Haus des Käufers unmöglich ist. Falls der Käufer vorweigt die Reparatur in seinem Haus, trägt er alle Kosten der Transportierung der Möbel.
- Der Hersteller garantiert die gute Qualität und Funktioneierung der Möbel für 12 Monate ab Kaufdatum (Auslieferungsdatum), beim Erhalten der Regeln zur Nutzung entsprechend der Zweckbestimmung.
- Um die Übereinstimmung der Waren mit dem Vertrag zu beweisen, soll der Verkäufer beim Kauf die Möbel auspacken, um die Qualität zu kontrollieren dem Käufer bei der Auslieferung im Geschäft zu zeigen.
- Beim Abnahme der gekauften Möbel kontrollieren Sie bitte den Zustand der Glaselemente (die ungeprüften, beschädigten Elemente unterliegen nicht der Garantie)
- Falls eine Nichtübereinstimmung der Waren vor dem Ablauf von sechs Monaten festgestellt wird, wird es angenommen (gemäß der Konsumentengesetz [ustawa o sp. kons.] dass es bereits bei der Auslieferung der Waren existierte. In diesem Fall ist der Verkäufer verpflichtet auszuweisen, dass es anders war, dass zur Zeit der Auslieferung die Ware mit dem Vertrag übereinstimmte.
- Für die Möbel, die zum Umsatz in den zur Montage außer dem Auslieferungsort bestimmten Paketen zugeliefert wurden, (sofern der Paket nicht beschädigt ist) beträgt die Zeit für die Anmeldung der Reklamation für die sichtbaren Fertigungsfehler und Mängel der Elemente (Zubehör) 7 Tage ab Kaufdatum.
- Die Reklamationen, die die Fehlern und Mangel der Möbel betreffen, die dem Käufer wie in dem Punkt 7 ausgemerkt wurden, erledigt der Verkäufer, und die Reklamationen wegen der von dieser Garantie umfassten Fehler, soll der Verkäufer unverzüglich dem Hersteller (Garantiegeber) übergeben.
- Eine Nichtübereinstimmung der Ware mit dem Vertrag soll innerhalb von einem Monat in der Kaufstelle angemeldet werden.
- Vor der Anmeldung der Reklamation dem Garantiegeber soll der Verkäufer zuerst selbst die Beschau der mit dem Vertrag nicht übereinstimmenden Waren durchführen. Die schriftliche Anmeldung der Reklamation ist erforderlich. (gilt das Datum des Poststempels und das Datum der Aufgabebestätigung vom Fax).
- Falls der Verkäufer die Reklamation nicht sofort erledigt, ist er verpflichtet ihren Empfang schriftlich zu bestätigen.
- Der Garantiegeber wird den Käufer innerhalb von 14 Tagen seit der Annahme der Meldung der Reklamation benachrichtigen, ob die Reklamation begründet und unbegründet ist, oder meldet sich beim Käufer um die Beschau durchzuführen und eventuell die Art und Weise und den Ort der Beilegung der Reklamation festzustellen.
- Im Falle einer unbegründeten Reklamation ist der Käufer verpflichtet die mit der Zufahrt der Servicepersonals verbundenen Kosten zu bezahlen.
- Die Abnahme der Garantiekarte durch den Käufer bei dem Einkauf der Möbel ist gleichbedeutend mit der qualitativen und quantitativen Abnahme, und bedeutet, dass keine Fehler oder äußere Mängel vorkommen.

Wenn die Reklamation begründet ist, kann der Käufer beanspruchen:

- Beseitigung der Fehler der Möbel oder Lieferung der fehlerfreien Möbel (Art. 577 § 1 KC (BGB)).
- Der Käufer hat die Möglichkeit die Ware gegen eine neue, mangelfreie Ware umzutauschen, nach der früheren Durchführung von vier wesentlichen und dokumentierten Reparaturen des Möbels (nach dem Umtausch einer Ware gegen eine neue läuft der Garantiezeit nicht von neuem an).
- Falls der Fehler nicht zu beseitigen ist, oder Beseitigung des Fehlers die Qualität der Möbel verschlechtern könnte, kann die Reklamation, mit Einwilligung des Käufers, mit der Reduzierung der Preis der Möbel erledigt werden.

Die Garantie des Herstellers umfasst nicht:

- Die beim Kauf sichtbaren Fehlern und Beschädigungen,
- Die Beschädigungen, die wegen der ungeeigneten Transport oder Verlegung und der unangebrachten Montage der Möbel entstanden sind, sowie die nach dem Verkauf infolge der unvorhergesehenen Begebenheiten und anderen Umständen entstanden sind.
- Die Beschädigungen, die wegen der unangebrachten Nutzung, Lagerung und Instandhaltung entstanden sind, sowie nach der Feststellung der Reparaturen, die von einer nicht dazu durch den Hersteller befugten Person durchgeführt wurden.
- Die Fehlern und Beschädigungen, infolgedessen die Preis der Waren beim Kauf reduziert wurde.
- Die Fehlern und Beschädigungen, die durch Tiere verursacht wurden.

CONDITIONS DE GARANTIE

FR

- Le meuble est sous garantie de fournisseur pendant 12 mois et ce à compter de la date d'acquisition de meuble par le client.
- Le chemin et la place sont mis par le garant.Les défauts doivent être corrigés à l'usine dans des cas exceptionnels :
a) si la réparation n'est pas possible chez le client
b) dans le cas où le client refuse de réparer le meuble chez lui, il doit prendre en charge les dépenses engendrées par le transport de meuble .
- Le fournisseur garantit la bonne qualité et le bon fonctionnement de meuble à conditions que le meuble est utilisé convenablement et une façon conforme à l'usage intentionné de meuble.dans la période de 12 mois à compter de la date de vente(date d'acquisition de la marchandise).
- Lors de la vente afin de vérifier la qualité, les meubles doivent être déballés par le vendeur, présentés à l'acheteur dans le magasin, afin de démontrer la conformité des marchandises au contrat.
- Dès la réception du mobilier acheté, veuillez vérifier l'état des éléments en verre (des pièces en verre endommagées, qui n'ont pas été vérifiées, ne sont pas couvertes par la garantie).
- Lorsque la non-conformité des marchandises a été constatée avant l'échéance de six mois, la Loi sur les ventes aux consommateurs présume qu'elle existait d'éjà au moment de la livraison. Ainsi c'est le vendeur qui est tenu de démontrer que ce n'était pas le cas, que les biens de consommation étaient conformes au contrat au moment de la livraison.
- Pour le mobilier fourni dans des emballages, destiné à être assemblé hors du lieu de livraison (sauf si l'emballage ne comporte pas de traces d'endommagement), le temps de déposer une réclamation relative à des défauts de fabrication apparents (non cachés) et le manque des pièces (accessoires) est de 7 jours à compter de la date d'achat.
- Les plaintes sur le manque ou l'endommagement de meuble, remis au client, comme stipulé dans l'article 7 doivent être résolues pas le fournisseur, tandis que les plaintes concernant les défauts couverts par la garantie, le client est obligé de renvoyer le meuble au fournisseur dans un délai Indu.
- La non-conformité des marchandises au contrat doit être déposée dans 1 mois à compter de son observation auprès du point de vente de meubles.
- Le client doit examiner le meuble qui porte une divergence (défaut) par lui-même avant de déposer une plainte auprès du fournisseur. Il est nécessaire de déposer une paine écrite (le cachet de la poste faisant foi, ou la date sur le reçu de fax).
- Si le vendeur ne résout pas la réclamation immédiatement, il doit confirmer son acceptation par écrit.
- Le garant doit informer le client que la plainte est justifiée ou non justifiée avant 14 jours à compter de dépôt de la plainte, tout comme il doit l'informer qu'il est nécessaire d'effectuer davantage d'examen et qu'il est possible de se mettre d'accord pour le la manière et le temps de résoudre le litige.
- Dans le cas où la plainte est sans fondement, le client est obligé de prendre à sa charge les frais de déplacement de service technique .
- Le fait que le client accepte la carte de garantie, au moment de l'achat de meuble, stipule qu'il approuve la quantité et la qualité et qu'il n'a repéré aucun endommagement, défaut ou manque .

L'acheteur, dont la réclamation est justifiable, peut demander que:

- Le vendeur supprime les défauts de l'ameublement, ou livre des meubles exempts de défauts (art. 577 § 1 du Code civil).
- L'acheteur est en mesure de bénéficier du remplacement de la marchandise par une nouvelle, exempte de défauts , après avoir réalisé quatre réparation de meubles importantes et documentées (après l'échange de marchandises par des meubles la période de garantie ne se déroulera pas de nouveau).
- Si le défaut n'est pas amovible ou sa réparation entraînerait l'abaissement de la qualité du meuble, le traitement de la réclamation peut se faire avec le consentement de l'acheteur en abaissant le prix des meubles.

La garantie du fabricant ne couvre pas:

- des défauts, dégâts visibles à l'achat,
- des dommages causés par le transport inadéquat ou la manipulation de meubles, et le mauvais assemblage ainsi que les effets résultant d'événements aléatoires ou d'autres circonstances,
- des dommages causés par une mauvaise utilisation, le stockage et l'entretien, ainsi que des réparations effectuées par une personne non autorisée par le fabricant,
- des défauts et dommages en conséquence desquels le prix du produit a été réduite lors de l'achat,
- des dommages et défauts causés par des animaux.

JÓTÁLLÁSI FELTÉTELEK:

HU

- A gyártó a bútör átvételének a dátumától számítva a termékre 12 hónapos garanciát vállal.
- A garanciális javítások elvégzésének a módját és helyét a Jótállást vállaló állapítja meg. A javításra csak kivételes esetben kerül sor a gyárban, ha annak elvégzése a vevő lakásában nem megoldható. Ha a vevő elutasítja, hogy a javítás a lakásában történjen, akkor fedeznie kell a bútörök fuvarozásának költségeit.
- A gyártó a termék rendeltetésszerű használatát esetén az átadás dátumától számított 12 hónapon át garantálja a bútörök magas minőségét és kifogástalan működését.
- Eladaskor, a bútör minőségének az ellenőrzése céljából az eladónak ki kell csomagolnia a bútöröket és az üzletben történő átadás előtt a vevőnek meg kell mutatnia, hogy az áru megfelel a szerződésben foglaltaknak.
- A megvásárolt bútörök átvételekor kérjük ellenőrizni az üveges elemek állapotát (A nem ellenőrzött, sérült üveges elemek nem terjed ki a garancia).
- Ha a termék hibája hat hónap eltelte előtt került megállapításra, a fogyasztói érdekesítővel szülő törvény szerint a termék már az átvételkor káros volt. Ilyenkor a viszonteladónak kell bebizonyítania, hogy ez nem így volt, a termék állapota az átvételekor megfelelt a szerződési feltételeknek.
- A besomagolt bútörök esetében, amelyek az átvételt helyen kívül lesznek összeszerelve, a látható (nyílt) hibák, vagy a hiányzó elemek (tartozékok) bejelentésének az ideje a vásárlás dátumától számított 7 nap (kivéve, ha a csomagoláson sérülés nyomait látni).
- A 7. pontban említett, a vevőnek átadott bútörök hibáit és hiányzó elemét érintő reklamációkat a viszonteladó intézi, a garanciális hibákra vonatkozó reklamációkat pedig az eladó azonnal átadja a gyártónak (Jótállást vállalónak).
- Az áru szerződéstől való eltéréseit a felfedését követő 1 hónapon belül kell bejelenteni annál az eladónál, aki a terméket értékesítette.
- A viszonteladó, mielőtt bejelentí a gyártónak (Jótállást vállalónak) a reklamációt, saját magának kell ellenőriznie a terméket, hogy az eltér-e a szerződésben foglaltaktól. A reklamációt írásos formában kell bejelenteni (a postabélyegző, fax dátuma számít).
- Ha a viszonteladó nem tudja azonnal elintézni a reklamációs ügyet, akkor köteles annak átvételét írásban visszaigazolni.
- A Jótállást vállaló a reklamáció átvételétől számított 14 napon belül téjőkoztatja a vevőt, hogy a benyújtott reklamáció megvalósított-e, vagy nem, vagy jelentkezik a vevőnél a reklamált termék ellenőrzése és a garanciális javítás elvégzésének a módjának és a helyének a megállapítása céljából.
- Abban az esetben, ha a reklamáció alaptalan, a szerviz megérkezésével kapcsolatos költségek a vevőt terheli.
- A termék vásárlása során a garanciális kártya átvétele azt jelenti, hogy a vevő megállapítja a termék megfelelő mennyiségét, minőségét és nem talál hibát a termékben és a termék minden eleme megvan.

Abban az esetben, amennyiben a reklamáció megvalósított:

- A vevő követelheti, hogy a viszonteladó elhárítsa a bútör hibát, vagy azt hibátlan állapotú bútörre cserélje (Ptk. 1. § 577. cikk).
- A vevőnek lehetősége van új, hibátlan termékre cserélnie, ha a bútörön négy, jelentős és feljegyzett javítást hajtottak végre (az új termékre történő kicserélés nem jelenti a garancia újrakészítését).
- Abban az esetben, ha a hiba elháríthatatlan, vagy elhárításával a termék minősége jelentősen csökken, a reklamáció elintézése a vevő beleegyezésével történik a bútör árának a leszállítása mellett.

A Jótállás nem terjed ki:

- a termék vásárlása során látható hibákra, sérülésekre
- a bútör helytelen szállásából, elmozdításából és szakszerűtlen szereléséből származó hibákra, valamint Visz Major körbe tartozó események okozta károokra,
- a helytelen használatból, tárolásból és karbantartásból származó hibákra, valamint olyan személyek által végrehajtott javítások felderítése esetén, akiket erre nem hatalmazott fel a gyártó,
- olyan hibákra és károokra, amelyek miatt a termék ára a megvétel során le volt szállítva,
- állatok által okozott meghibásodásokra és károokra.

