



INSTRUKCJA MONTAŻU
ASSEMBLING INSTRUCTIONS
ISTRUZIONI DI MONTAGGIO
MONTAGEANLEITUNG
ISTRUCOES DE MONTAGEM
MANUAL DE MONTAJE
NOTICE DE MONTAGE
UPUTE ZA SASTAVLJENJE
UPUTSTVA ZA MONTIRANJE
MONTÁŽNÍ NÁVOD
MONTÁŽNY NÁVOD
SZERELÉSI UTASÍTÁS

KRIS



3h

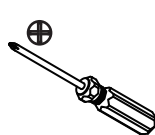

x1

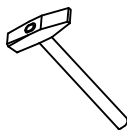

x1



x1

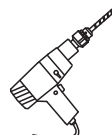

x1

31-10-2016

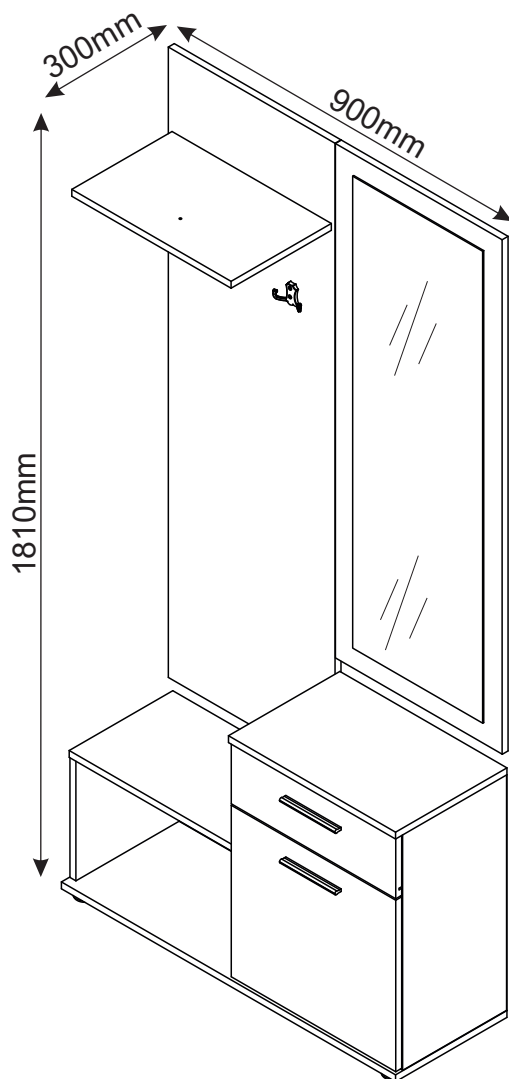

*PRZED ROZPOCZĘCIEM
ZAPOZNAĆ SIĘ Z ZAŁĄCZONĄ
INSTRUKCJĄ MONTAŻU*

**BEFORE STARTING, REFER
TO THE ASSEMBLING ADVICE
IN ANNEX**

*AVANTI DI COMMINCIARE,
RIPORTATE AGLI CONSIGLI DI
MONTAGGIO*

**VOR DIE MONTAGE, BITTE
BEILIEGENDE ANWEISUNGEN
FOLGEN**

*ANTES DE COMERCAR, ADIAR-
SE AOS CONSELHOS DE
MONTAGEM EM ANEXO*

**ANTES DE EMPEZAR
CONSULTE LOS CONSEJOS
PARA EL MONTAJE**

*AVANT DE COMMENCER, SE
REPORTER AUX CONSEILS
DE MONTAGE EN ANNEXE*

**PRIJE MONTAŽE MOLIMO
DA SE UPOZNATE SA
INSTRUKCIJOM MONTAZE**









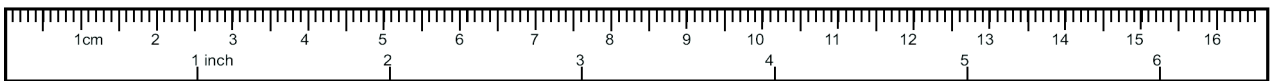
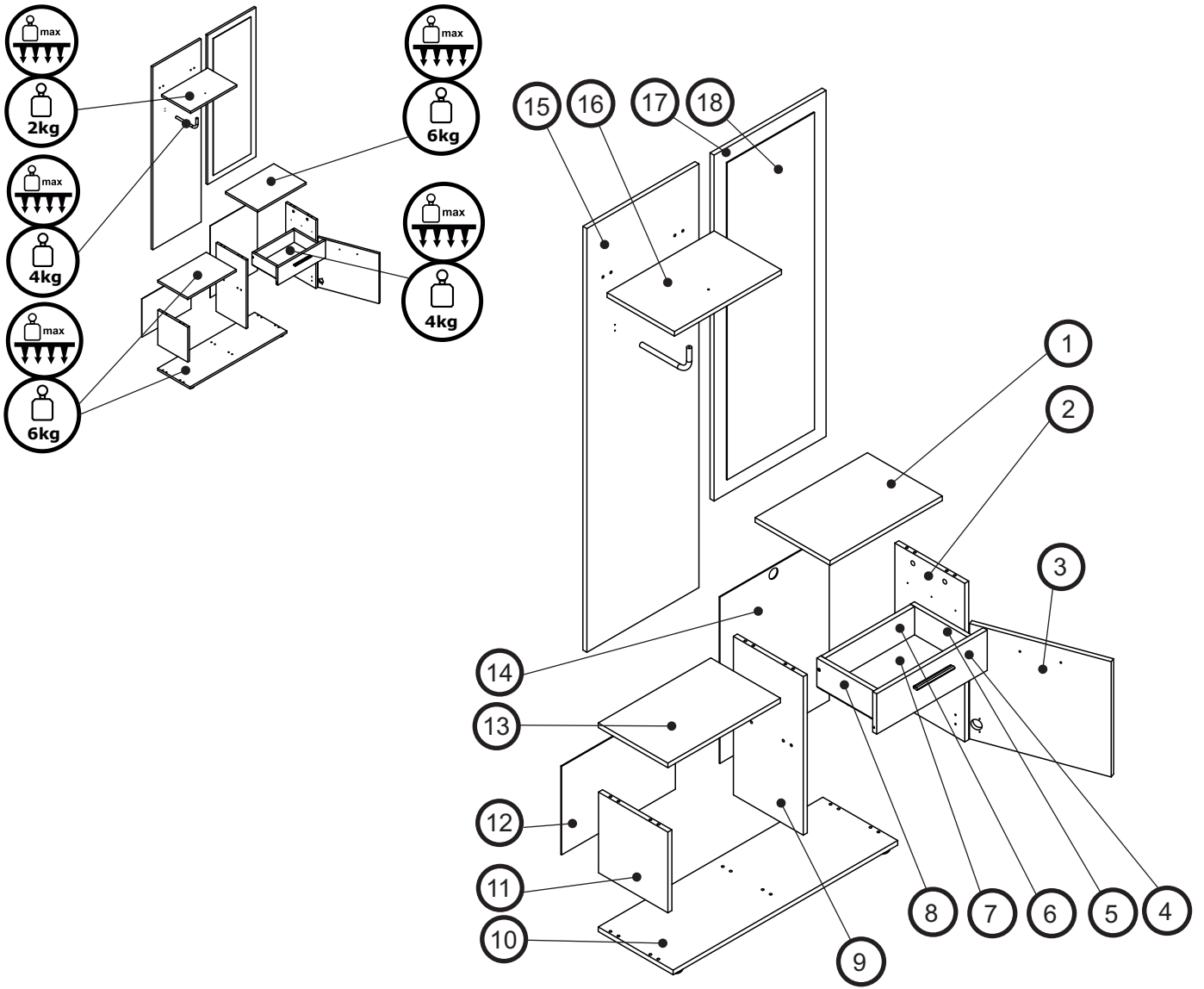

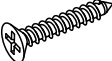





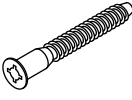
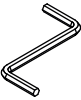

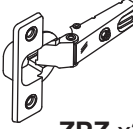
*PRE NEGO ŠTO POČNETE,
PROČITAJTE UPUTSTVA
ZA INSTALACIJU.*

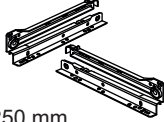
**PŘED MONTÁŽÍ
SI POZORNĚ PŘEČTĚTE CELÝ
NÁVOD K MONTÁŽI**

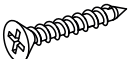
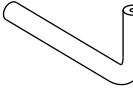
*PRED MONTÁŽOU
SI POZORNE PREČITAJTE
CELÝ NÁVOD K MONTÁŽI*

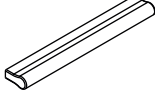
**MEGKEZDÉSE ELŐTT
OLVASSA EL A
TELEPÍTÉSI
UTASÍTÁSOKAT**

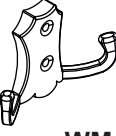

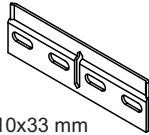
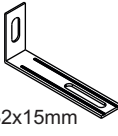
 Ø45x15 mm SO x5	 Ø4x25 mm EL x5	 Ø8x30 mm KK x20	 Ø1,4x25 mm G x40	 Ø5 mm TM x8	 Ø15X12 mm MS x8	 Ø17 mm ZM x4
 Ø7X50 mm KF x12	 KdK x1	 Z x2	 ZPZ x2	 H2 x2	 Ø4x16 mm EZ x4	 250 mm PR x1
 Ø3,5x15 mm EM x27	 Ø3,5x20 mm EN x8	 Ø12 mm WP x1	 M4x25 mm EX x2	 BL x3	 128/160 mm UZ x2	 Ø4x30 mm EG x4
 WM x2	 WX x8	 110x33 mm SX x4	 75x32x15mm KT x1			

1

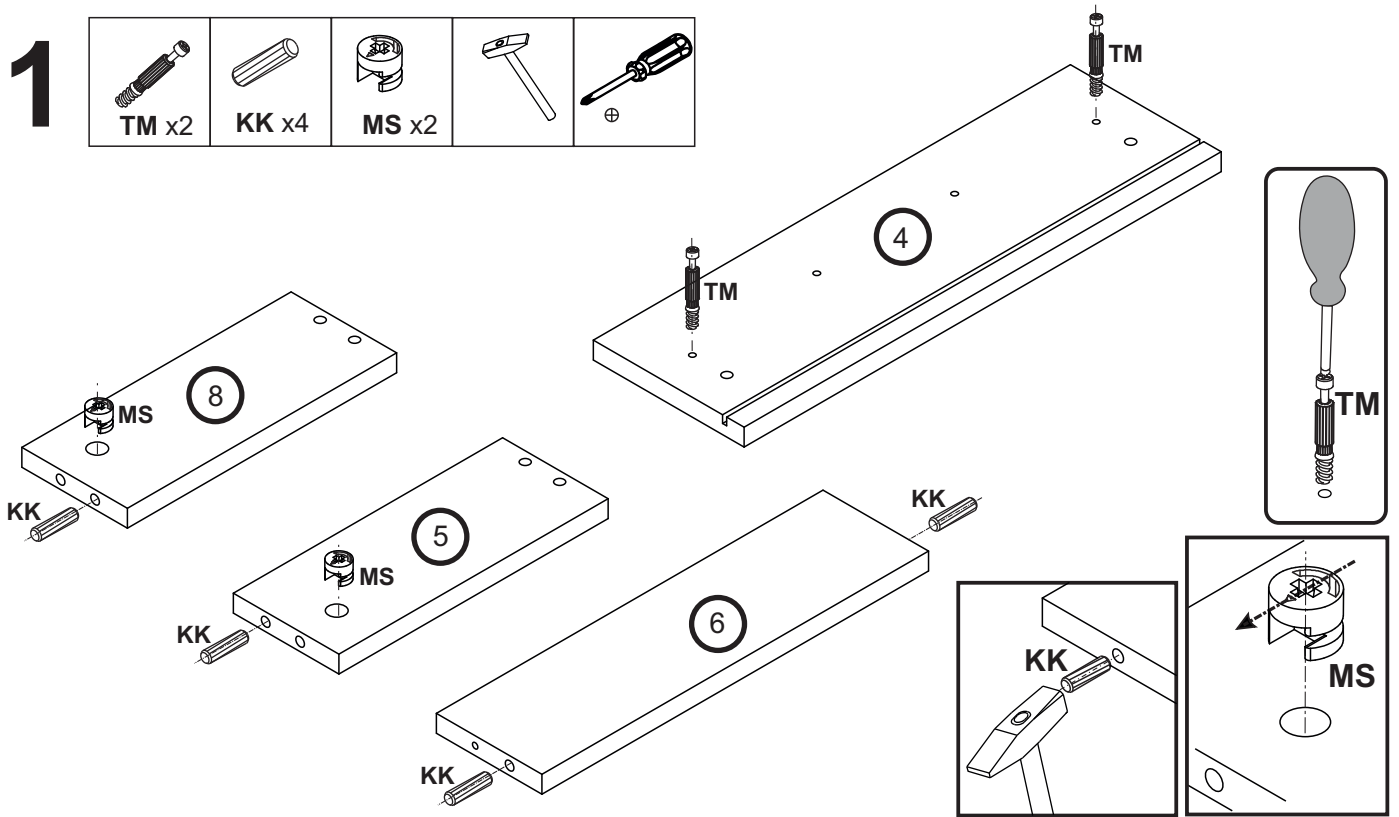
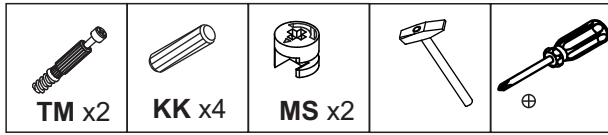

2

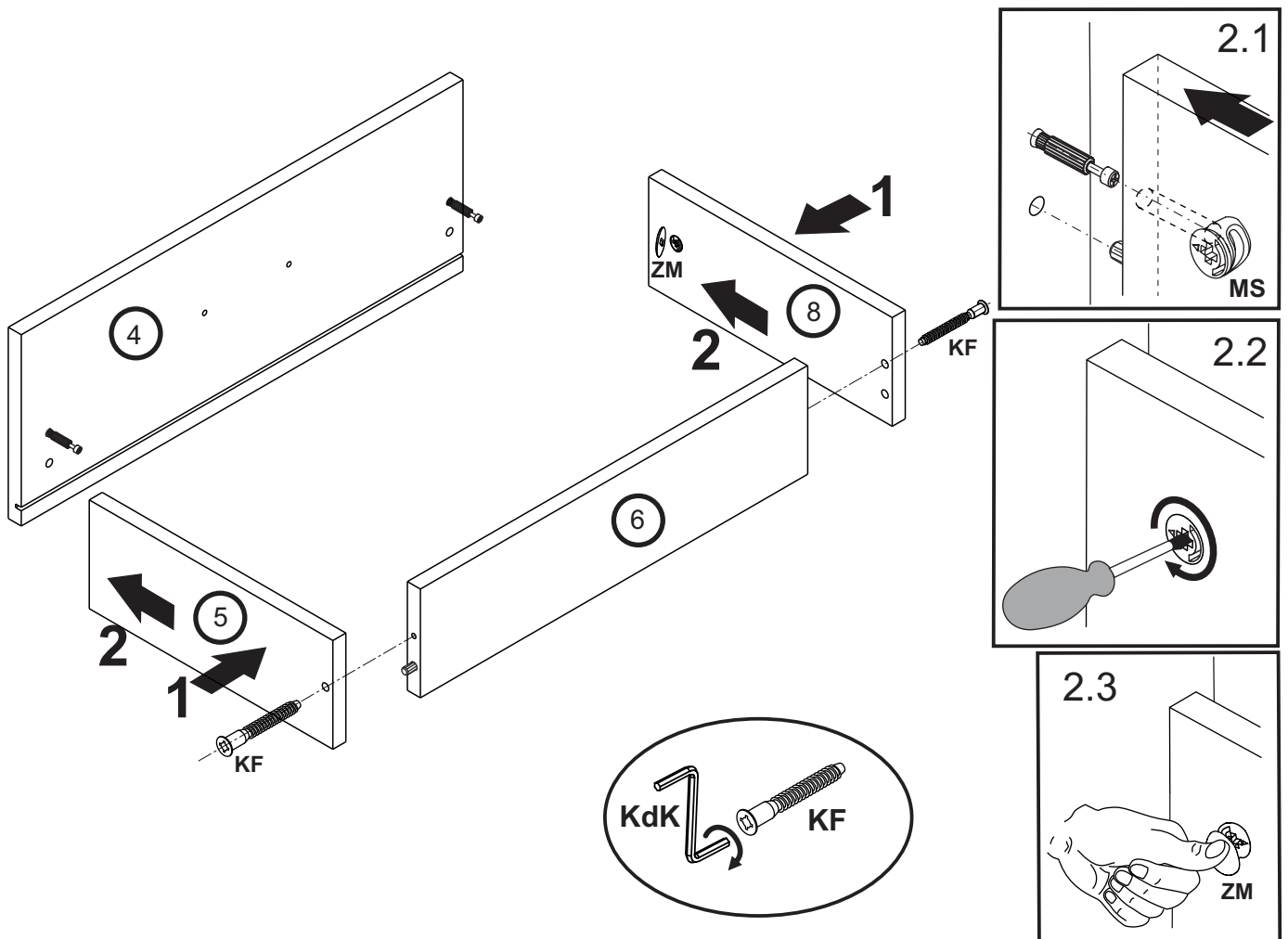
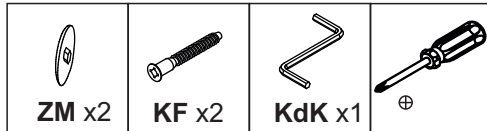

3

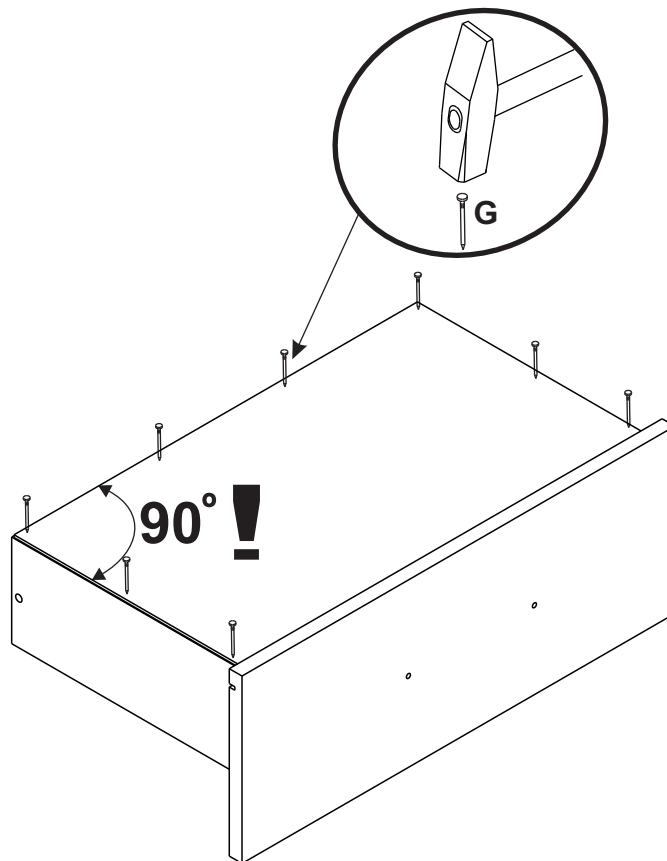
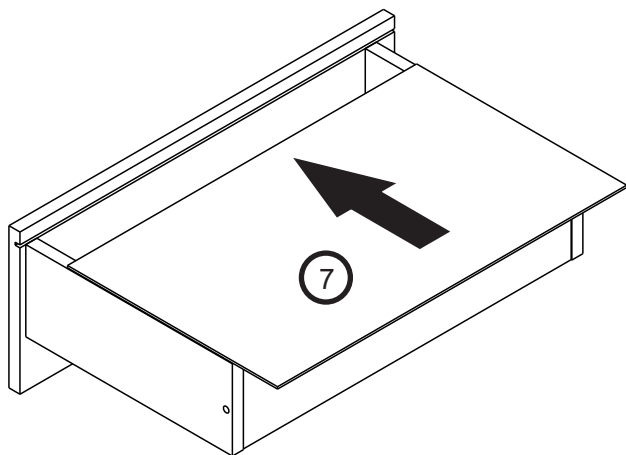
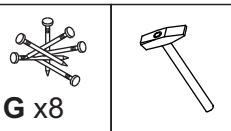

4

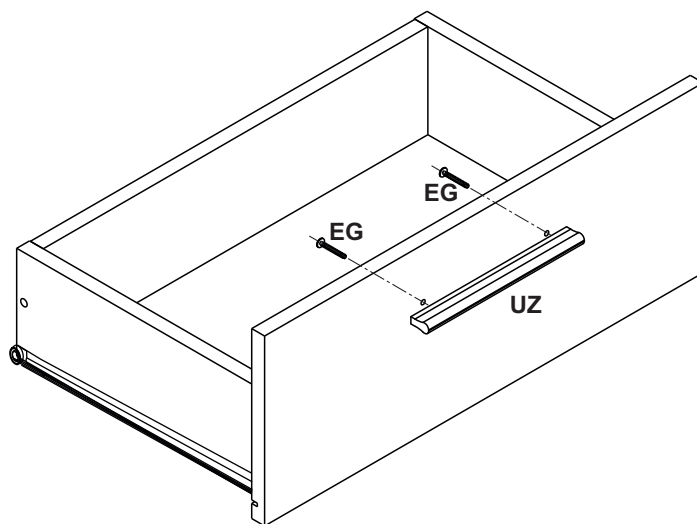
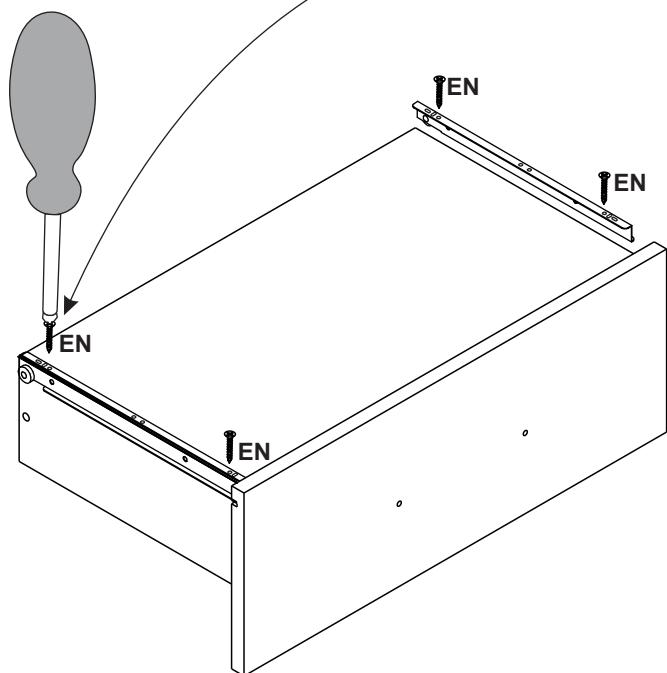
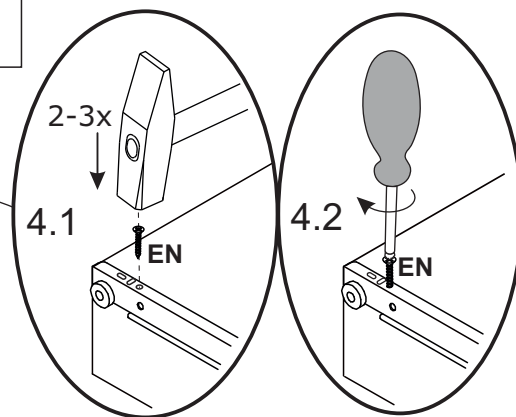
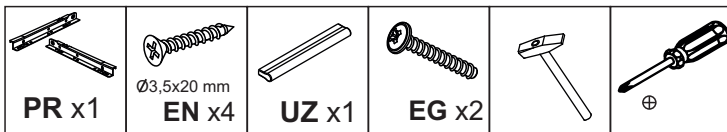

5

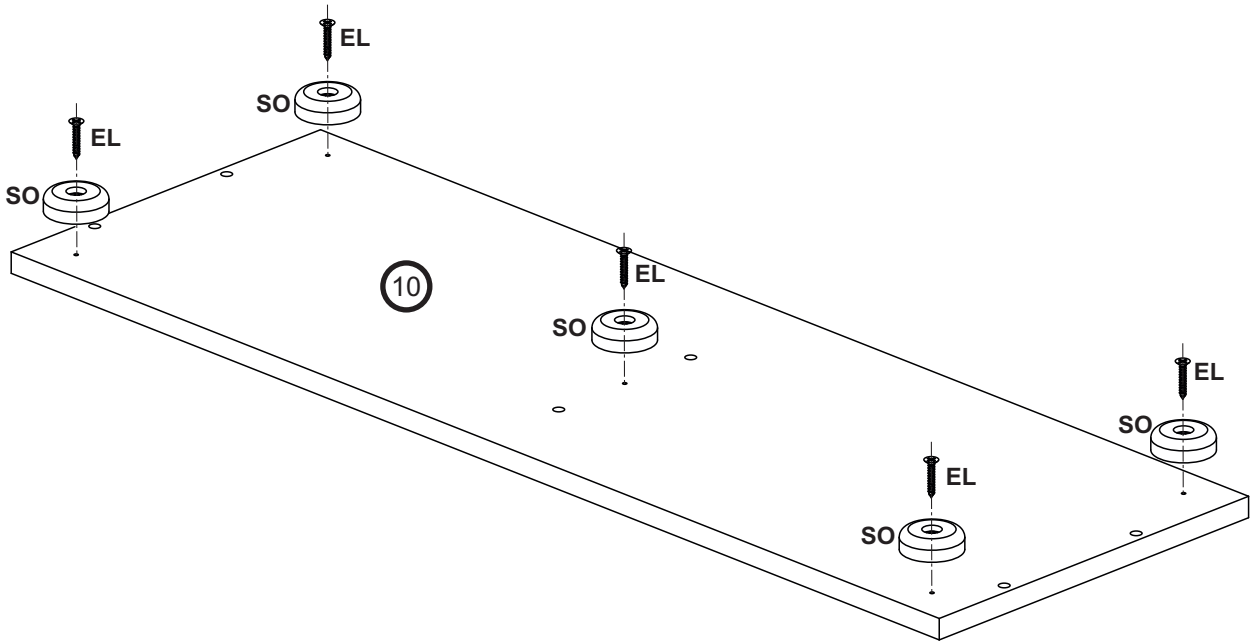
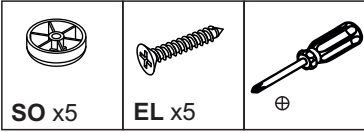

6

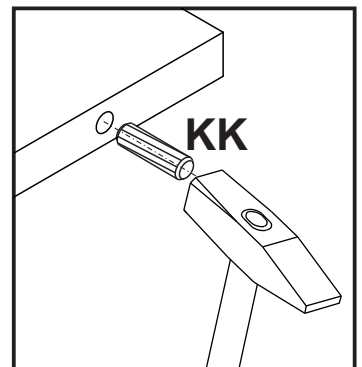
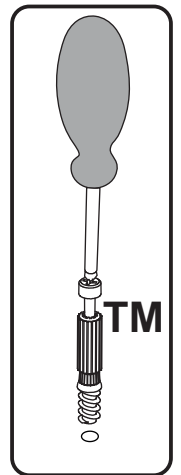
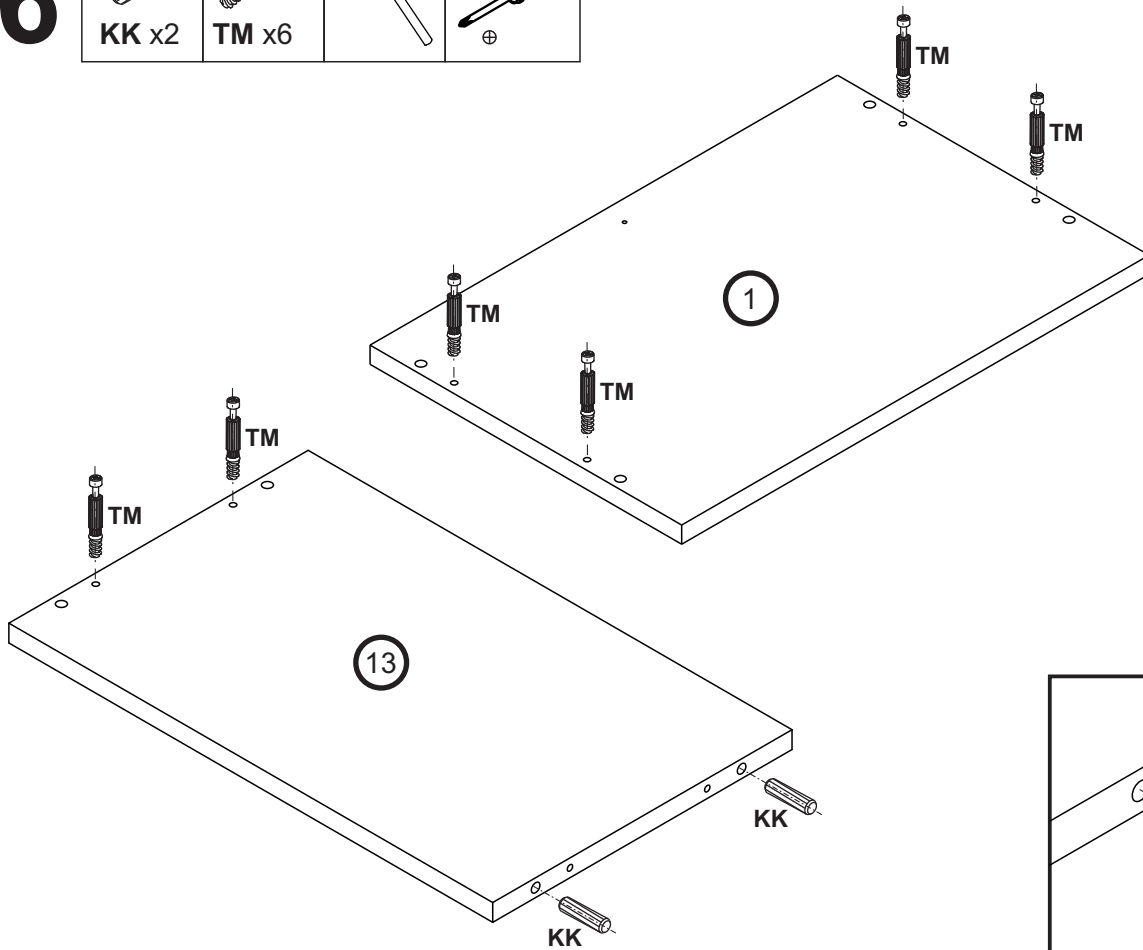
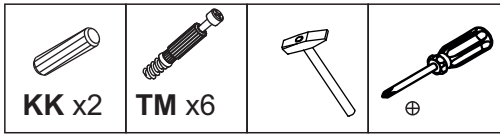

7

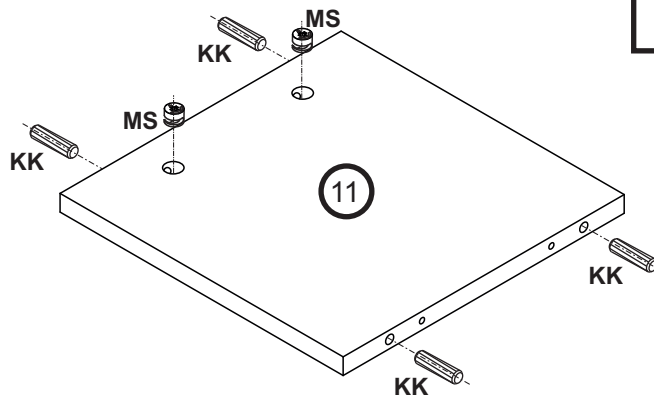
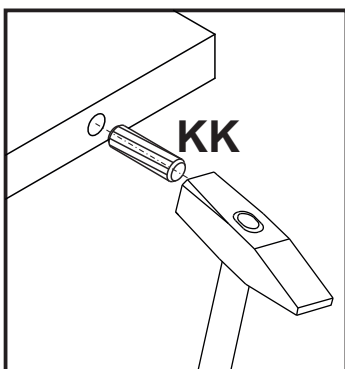
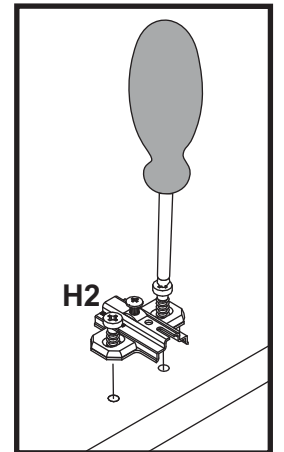
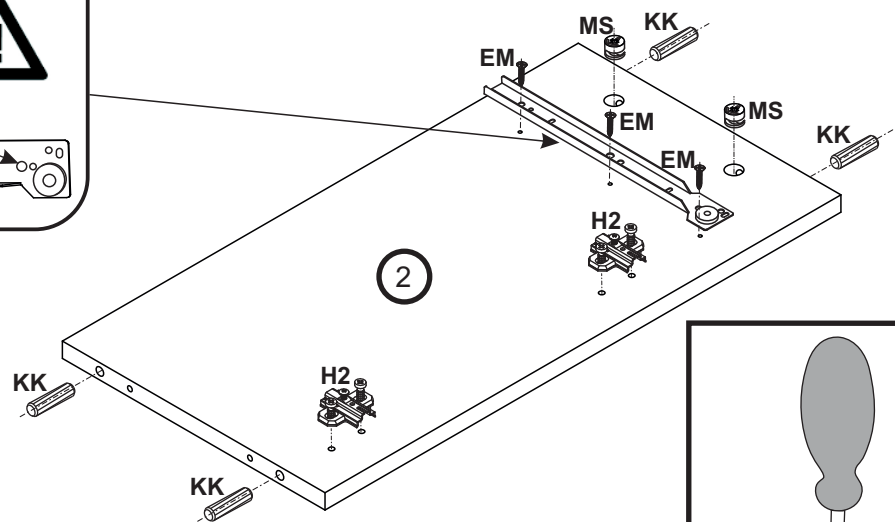
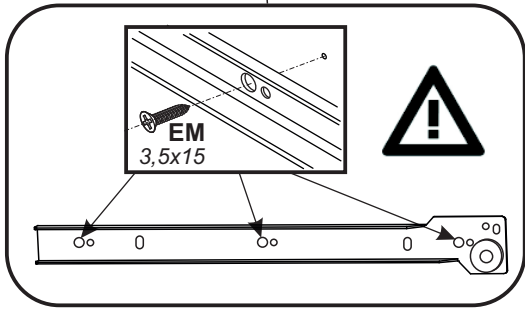
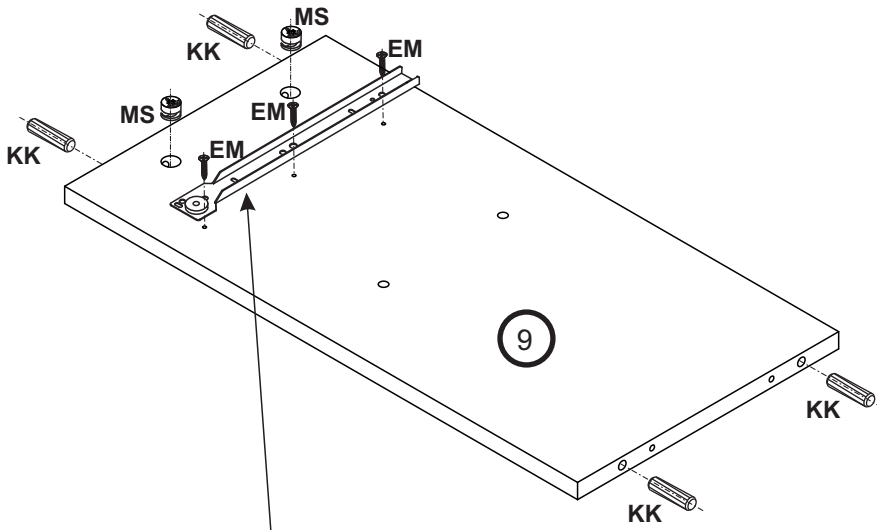
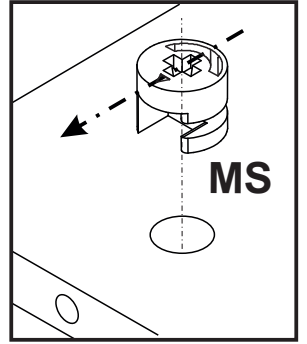
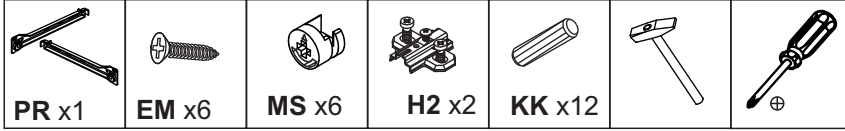

8

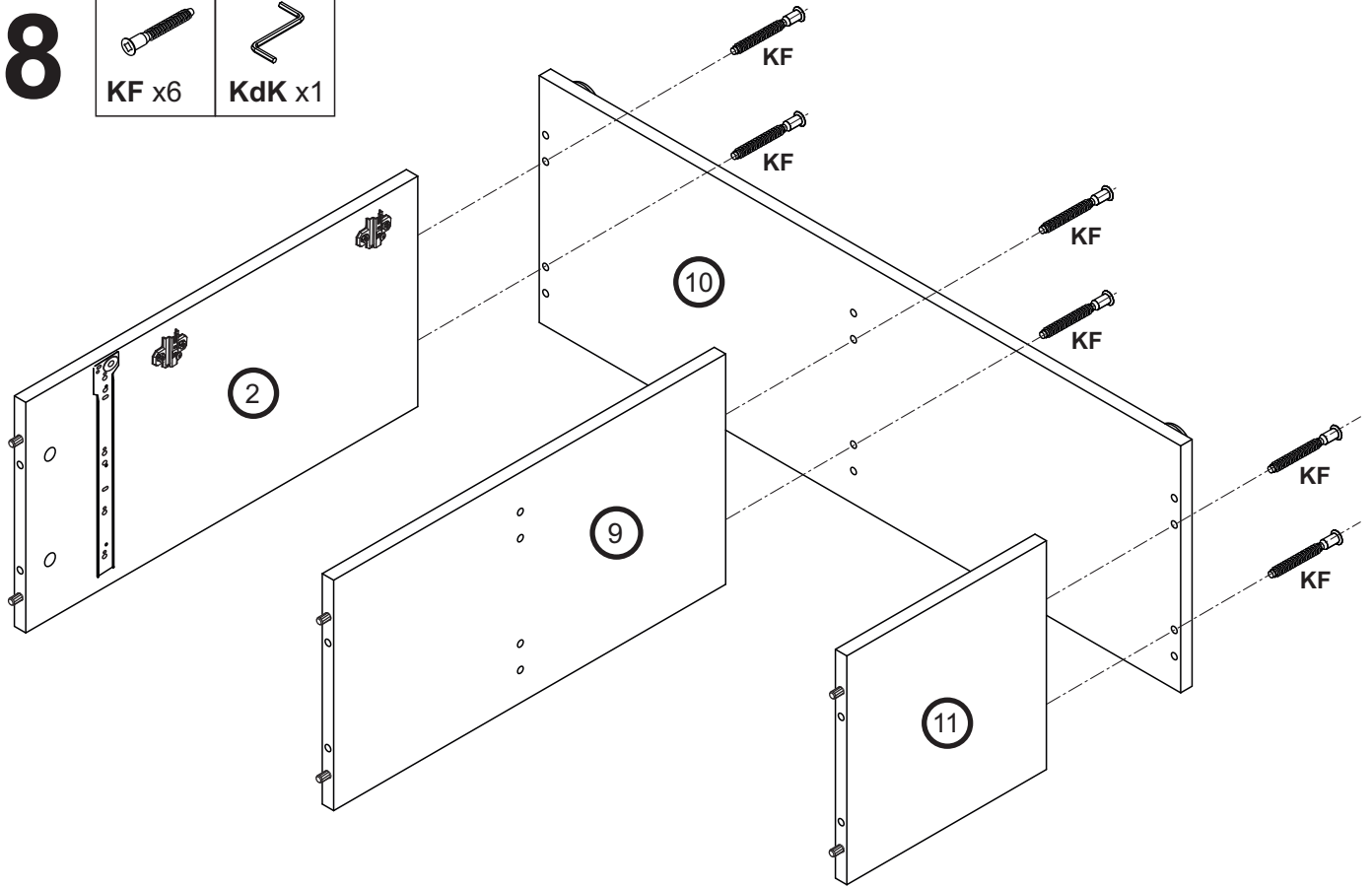
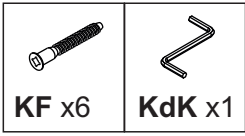

9

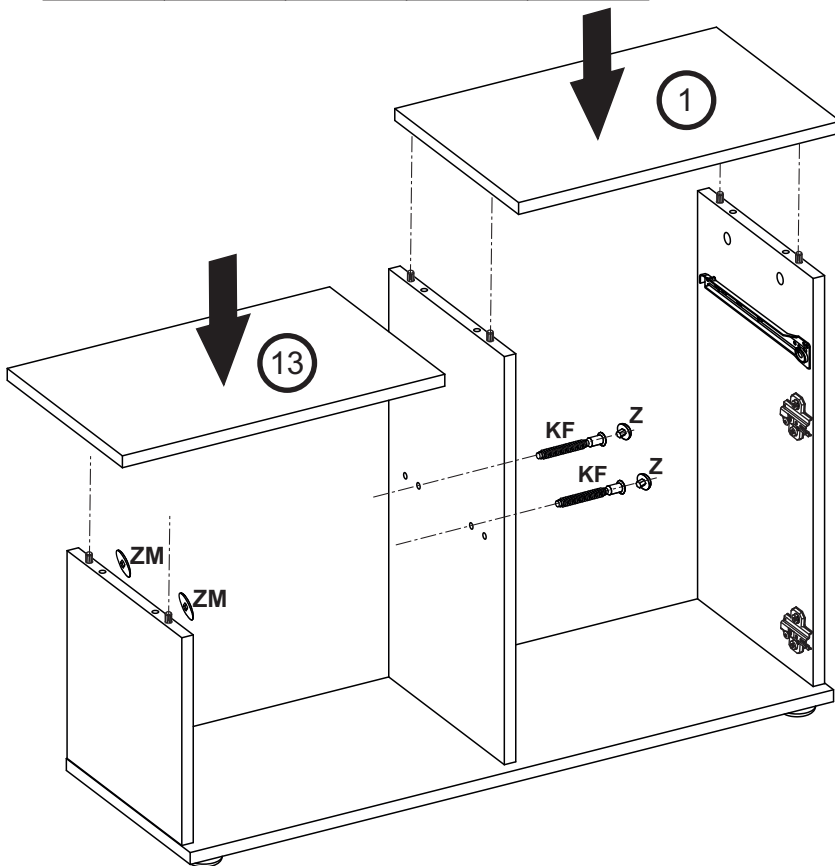
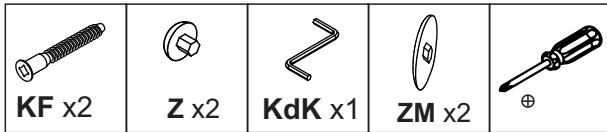

9.1

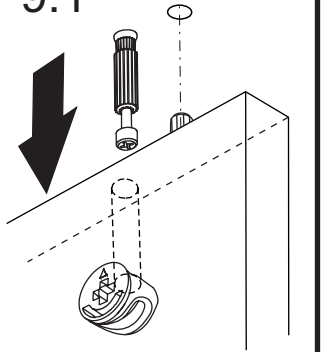

9.2

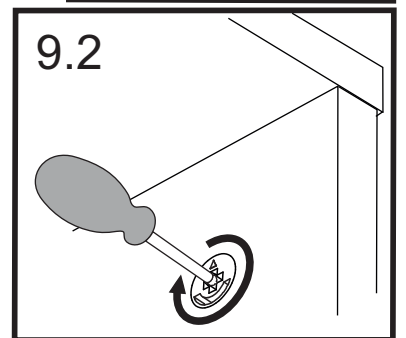

9.3

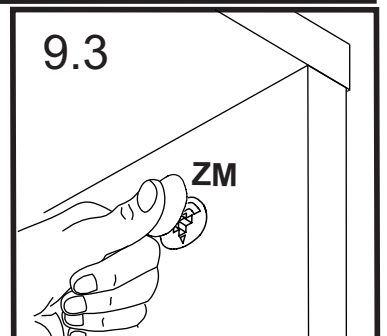

10

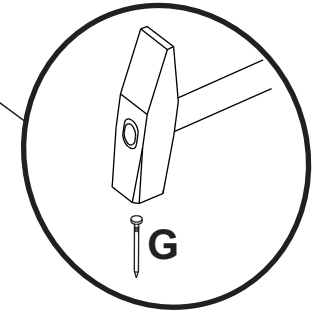
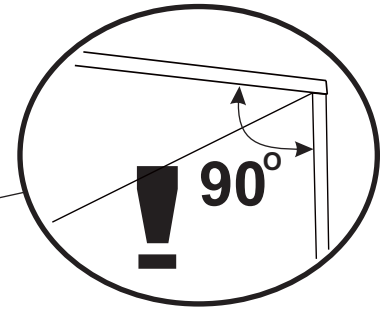
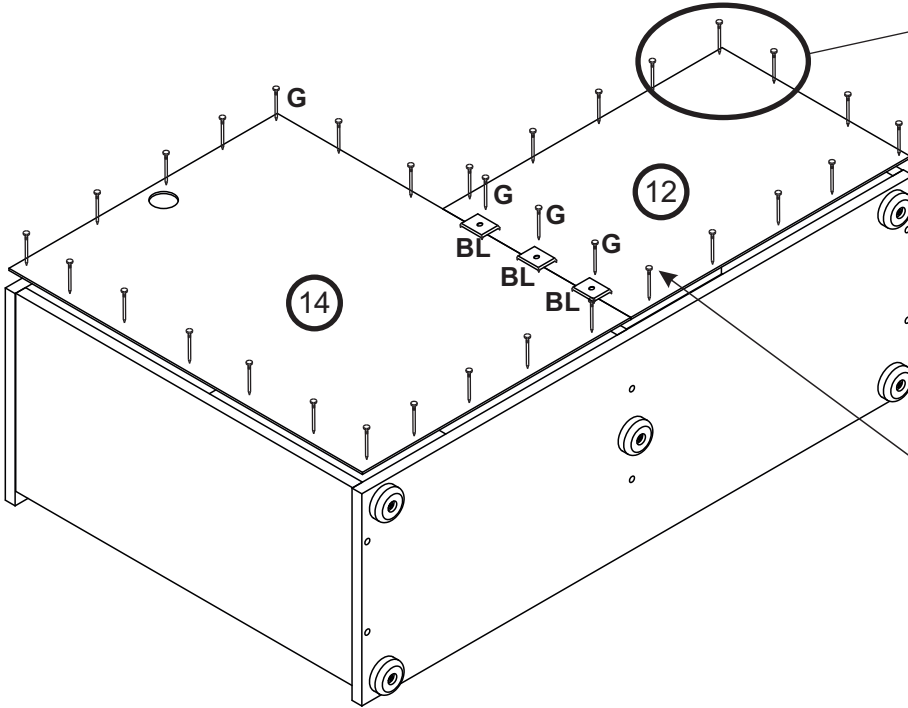
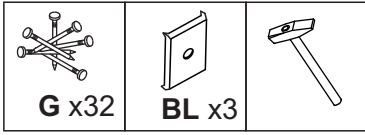

11

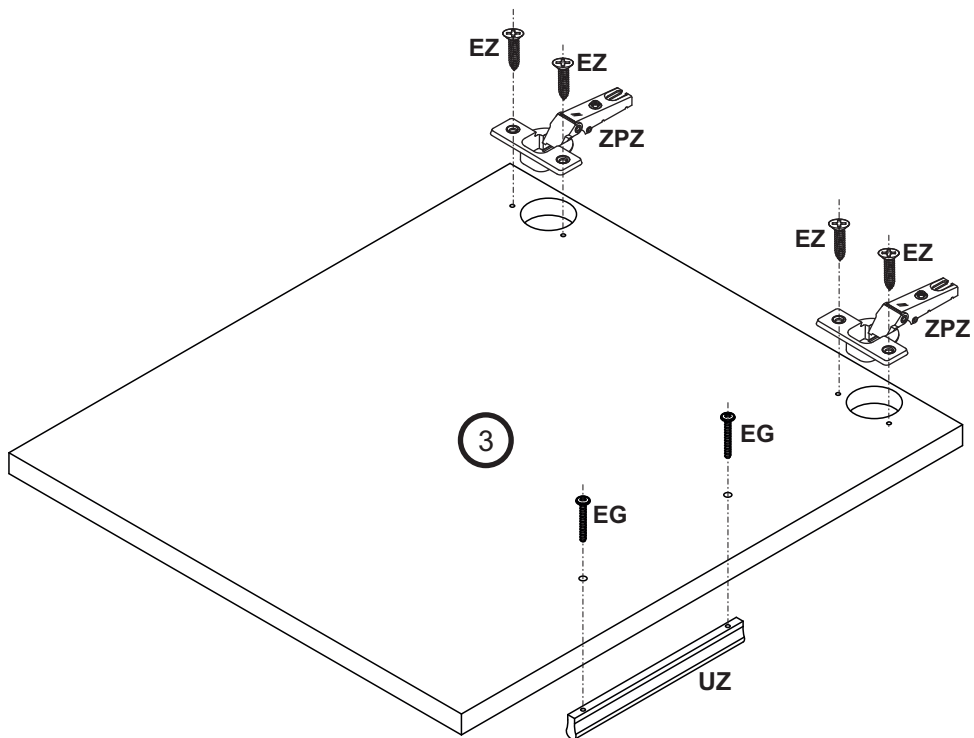
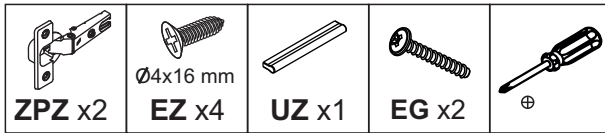

12

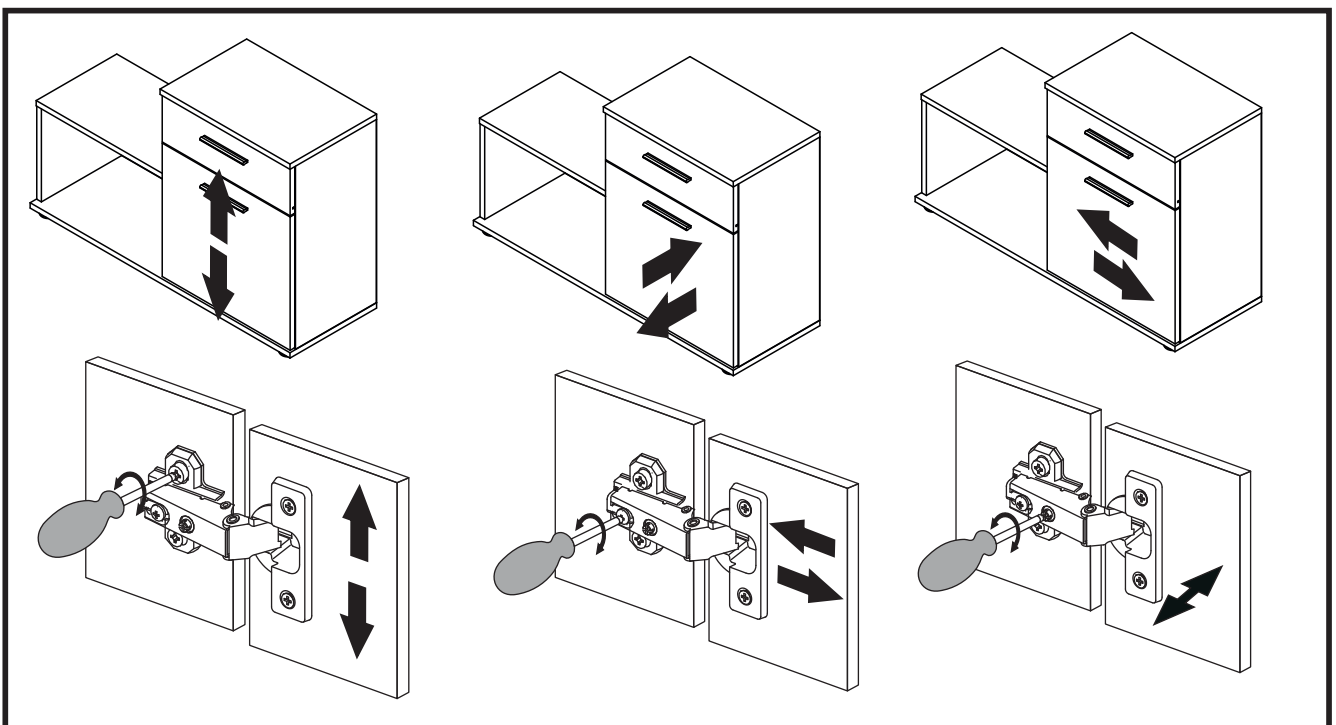
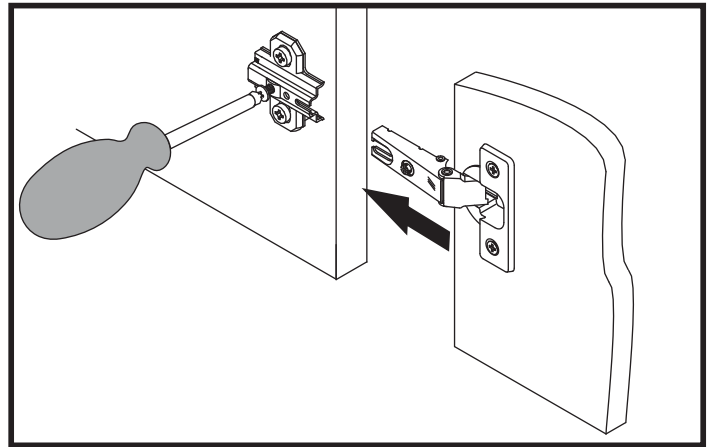
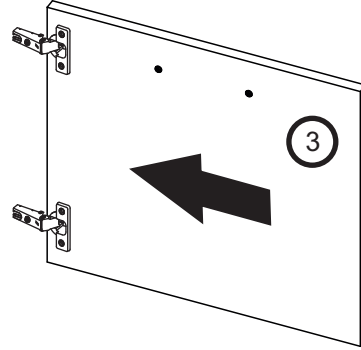
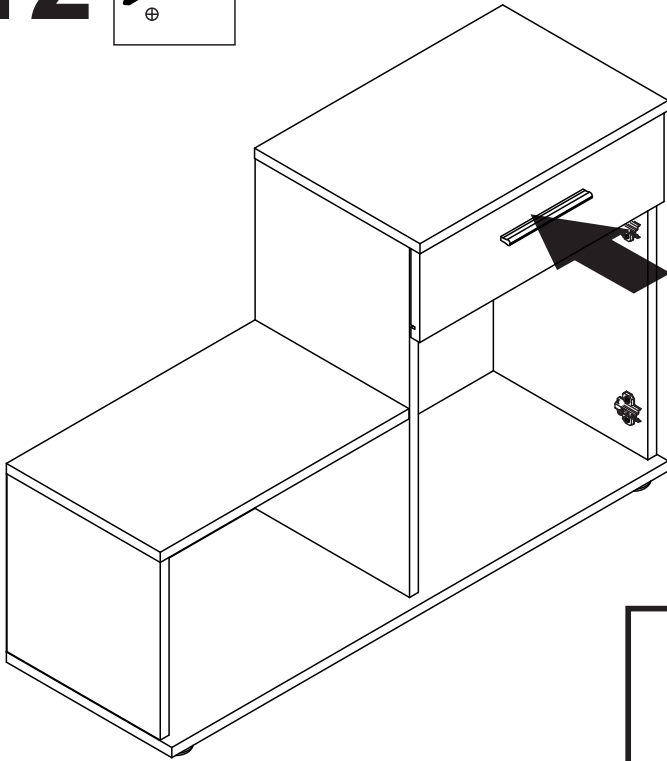
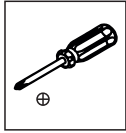



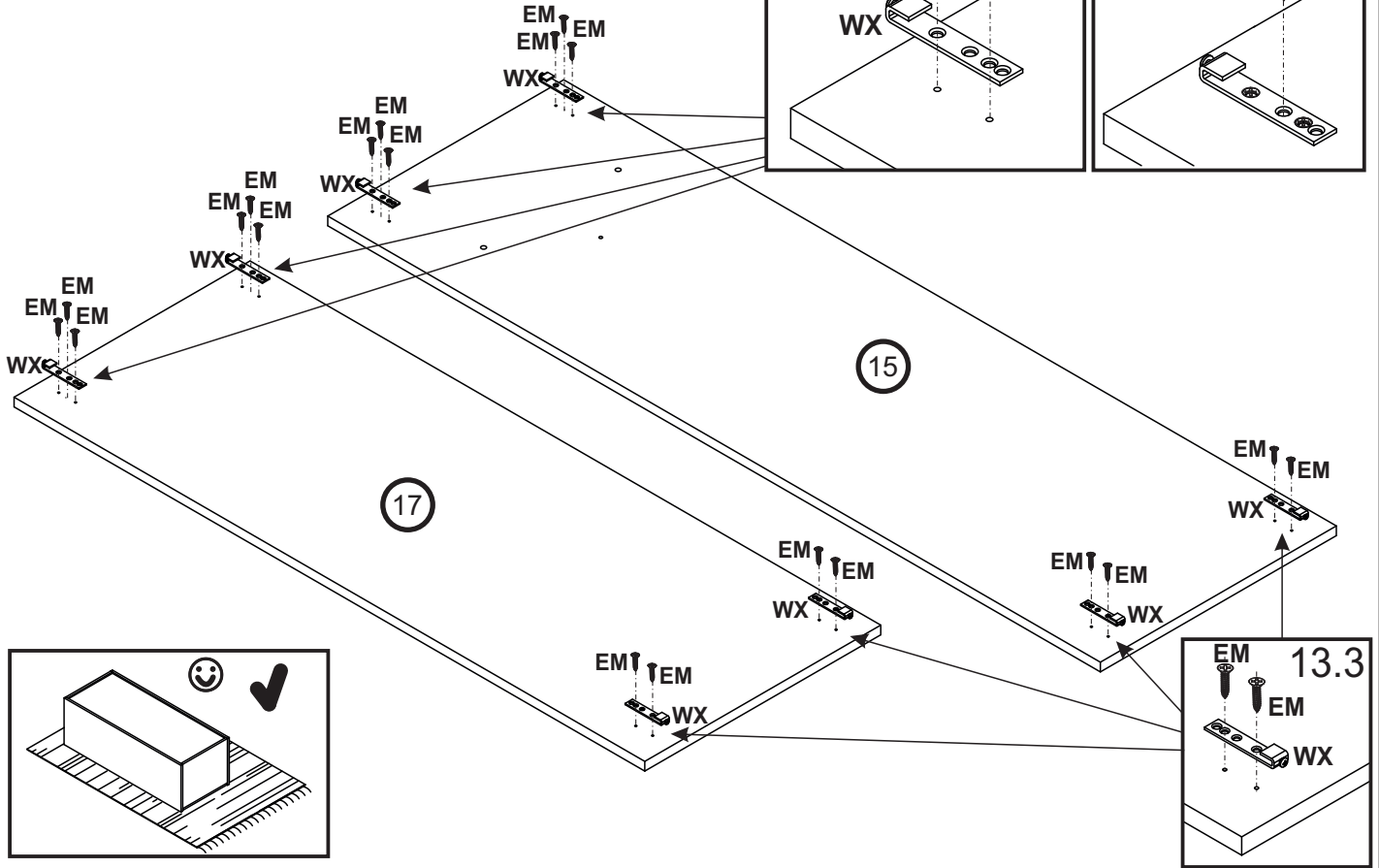
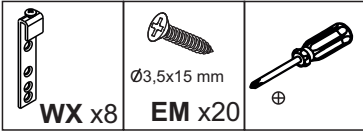

13

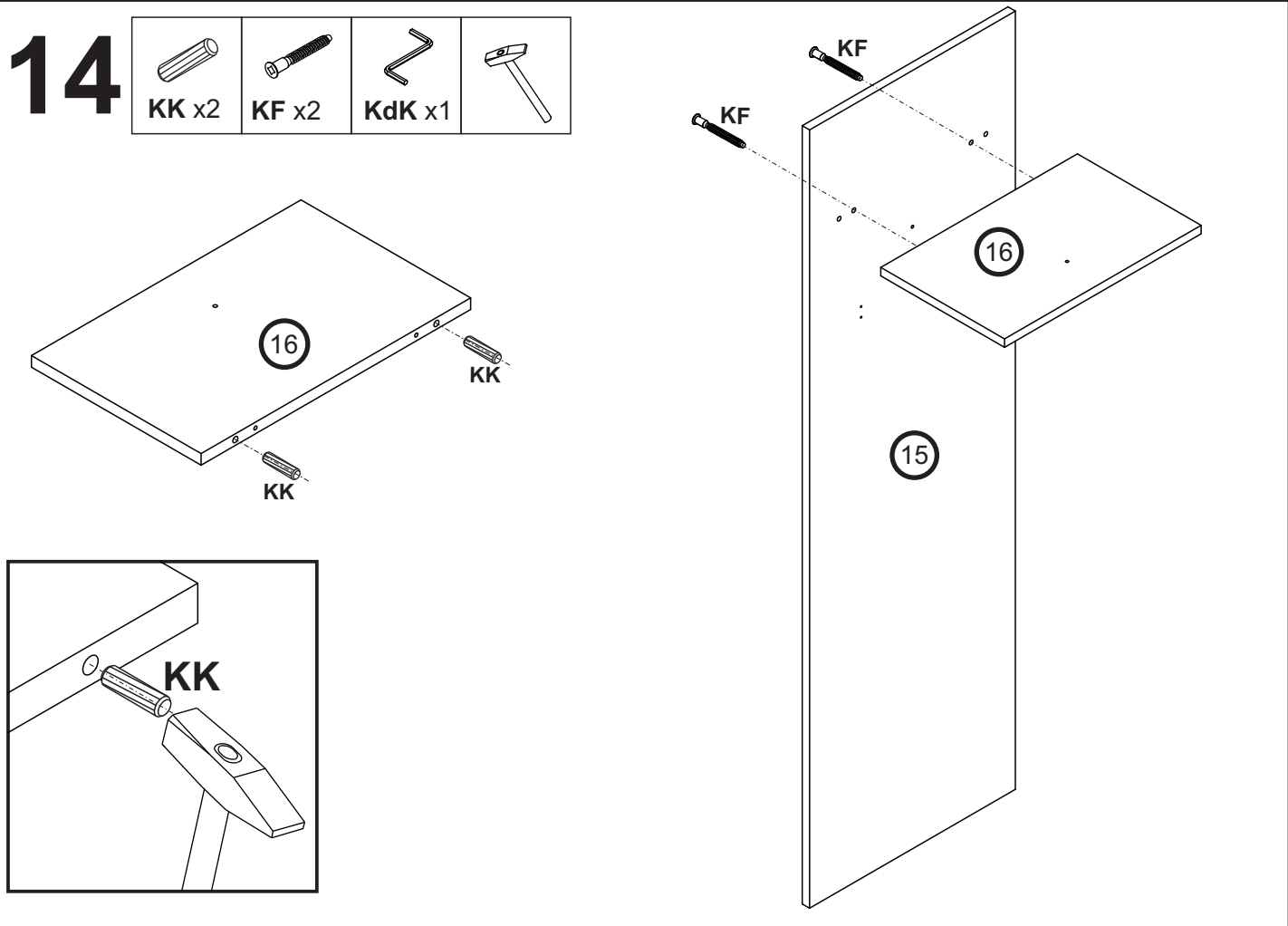
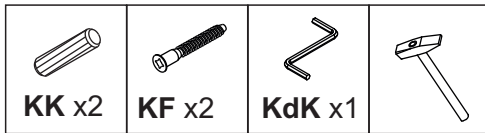

14

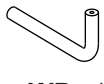

15

 WM x2	 WP x1	 EX x2	 Ø3,5x20 mm EN x4	
--	--	--	--	---

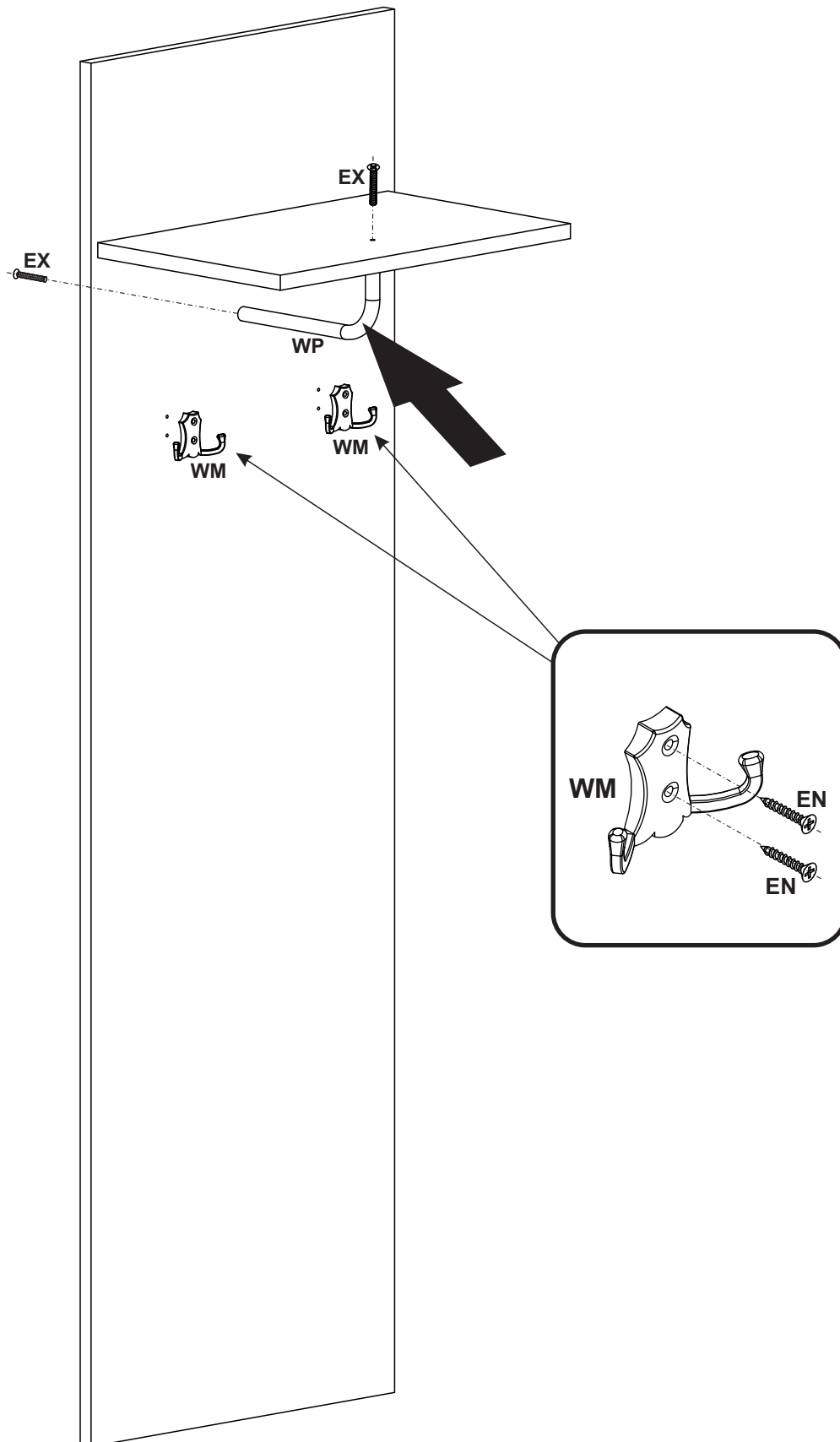

16

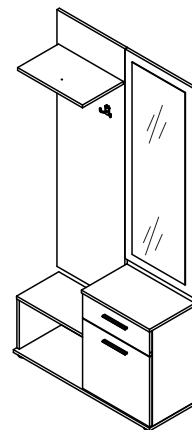
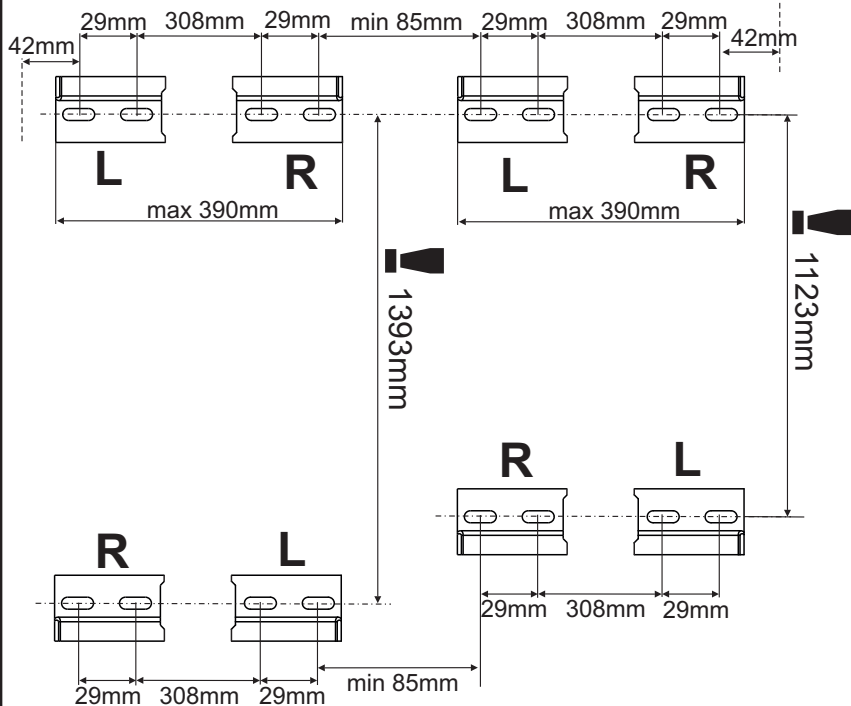
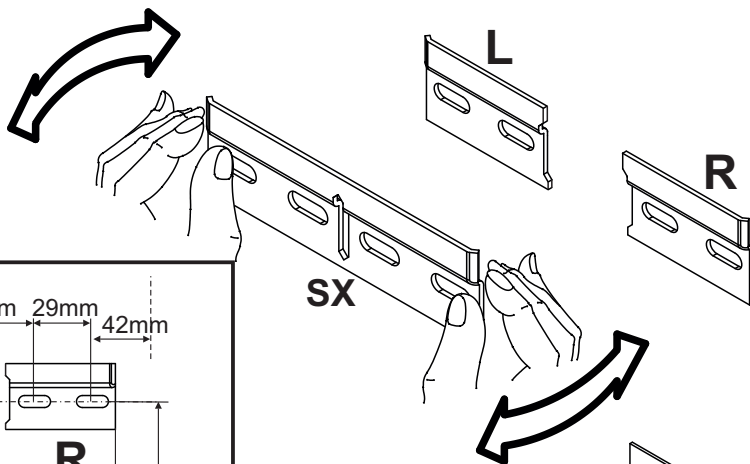
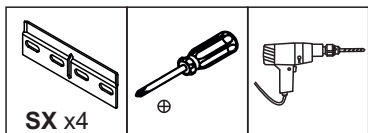

DEUTSCH

Um ein Umkippen des Möbelstücks zu verhindern, muss es fix an der Wand befestigt werden. Überprüfen Sie die Art und Stärke der Wand. Passen Sie die passenden Schrauben und Dübel für die Wände. Die Installation muss von einer sachkundigen Person durchgeführt werden.

ITALIANO

Per evitare che si rovesci sopra i mobili in modo permanente attaccarlo al muro. Controllare il tipo e la resistenza della parete. Regolare le viti e tasselli per le pareti. L'installazione deve essere effettuata da una persona competente.

FRANCAIS

Pour éviter le basculement des meubles, fixer au mur de façon permanente. Vérifiez le type et la solidité du mur. Choisir les vis et chevilles appropriées pour les murs. L'installation doit être effectuée par une personne compétente.

ENGLISH

To prevent the piece of furniture from falling over, please attach it permanently to the wall. Check the type and strength of the wall. Choose the appropriate screws and dowels for the walls. Installation must be performed by a competent person.

POLSKI

Aby zapobiec przewróceniu się mebla, należy na stałe przymocować go do ściany. Sprawdź rodzaj i wytrzymałość ściany. Dobierz odpowiednie wkręty i kołki do rodzaju ściany. Montaż musi zostać wykonany przez osobę specjalistyczną.

ESPAÑOL

Para evitar que se vuelquen los muebles, fíjelos permanentemente a la pared. Compruebe el tipo y resistencia de la pared. Escija los tornillos y tacos apropiados para la pared. La instalación debe ser realizada por una persona especializada.

ČESKÝ

Chcete-li zabránit převrácení nábytku, je potřeba ho trvalo připevnit ke stěně. Zkontrolujte typ a nosnost stěny. Vyberte si vhodné šrouby a hmoždinky pro stěny. Instalace musí být provedena kvalifikovanou osobou.

PORTUGUÊS

Para evitar tombamento móveis permanentemente anexá-lo a parede. Verifique o tipo e resistência da parede. Escolha de parafusos e buchas apropriadas para a parede. A instalação deve ser efectuada por uma pessoa competente.

SLOVENSKÝ

Ak chcete zabránit prevráteniu nábytku, je potrebné ho trvalo pripnúť ku stene. Skontrolujte typ a nosnosť steny. Vyberte si vhodné skrutky a hmoždinky pre steny. Inštalácia musí byť vykonaná kvalifikovanou osobou.

HRVATSKI

Da biste spriječili prevrtanja namještaja trajno ga pričvrstite na zid. Provjerite tip i snagu zida. Podestite odgovarajuće vijke i utikači za zidove. Instalacija mora biti izvedena od strane stručne osobe.

MAGYAR

A bútörök felborulásának megelőzése érdekében tartósan rögzítse a falhoz. Ellenőrizze a fal típusát és terhelhetőségét. Válassza ki a falhoz megfelelő csavarokat és tipliket. Az installációt szakképzett személynek kell elvégeznie.

SRPSKI

Da biste spriječili prevrtanja namještaja trajno pričvršćivanje na zid. Proverite tip i snagu zida. Podestite odgovarajuće šrafove i čepove za zidove. Instalacija mora biti izvedena od strane nadležnog lica.

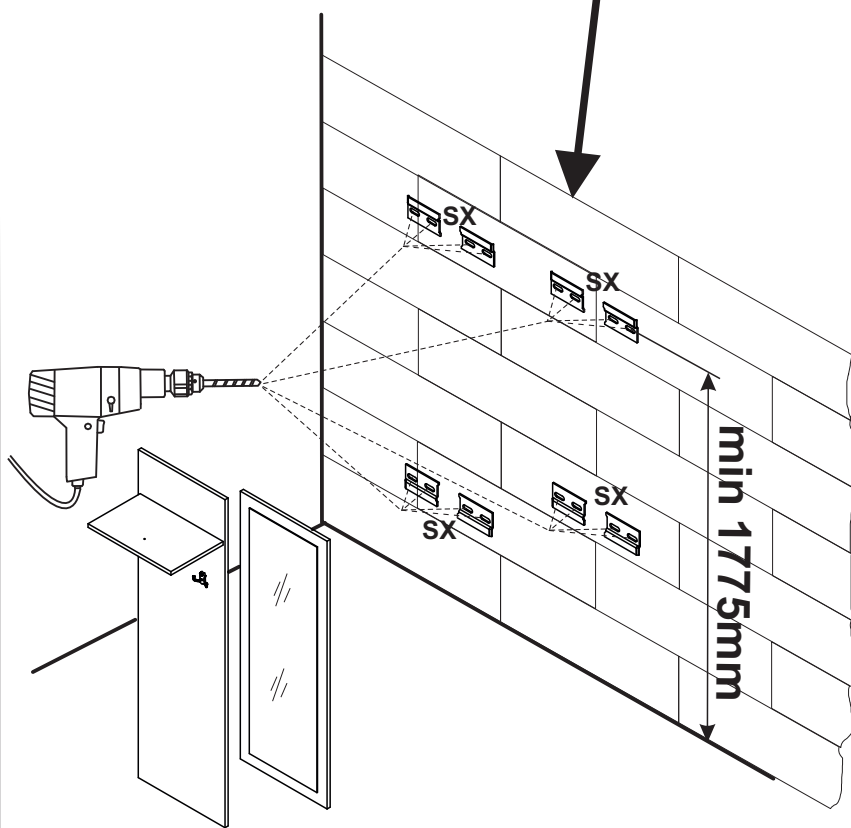

17

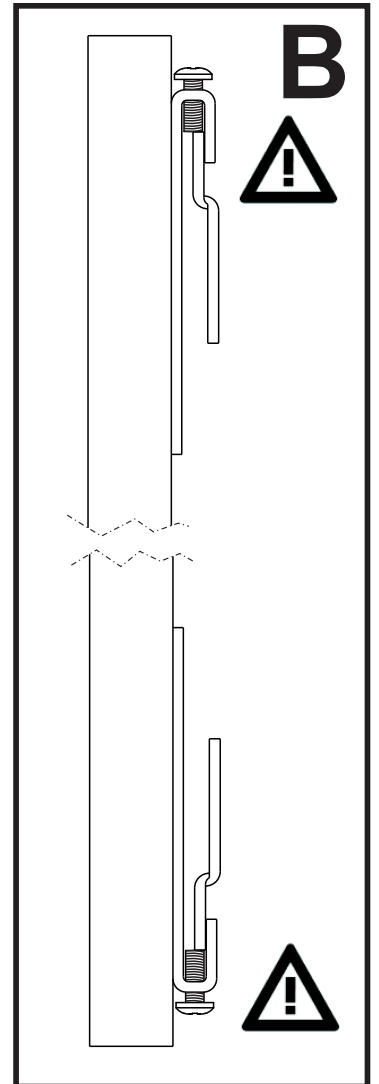
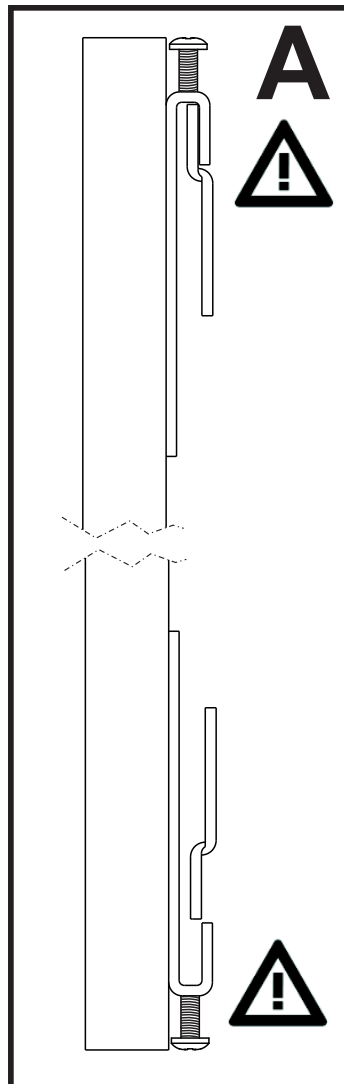
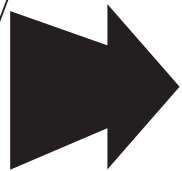
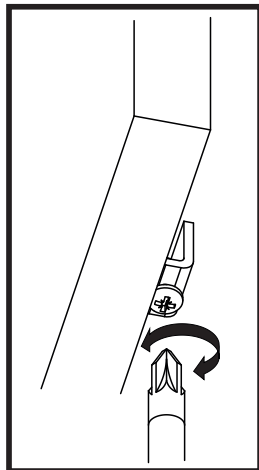
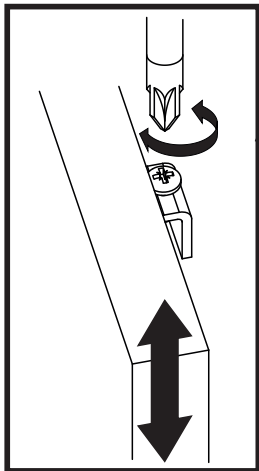
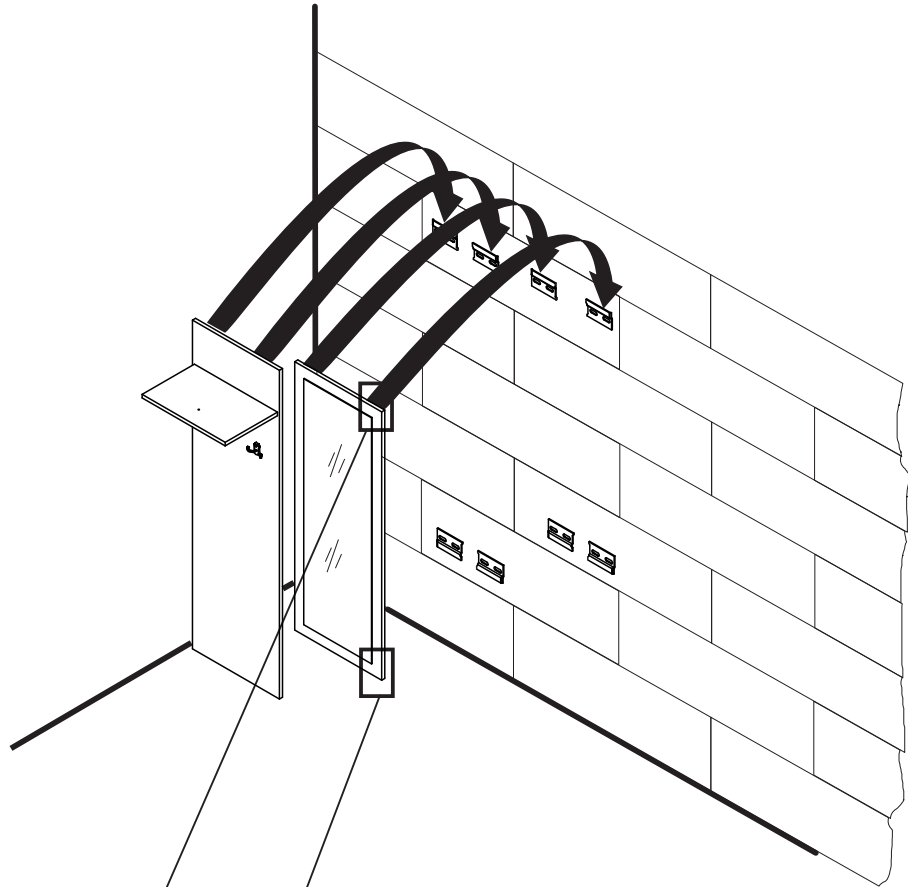
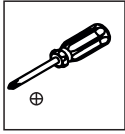

18

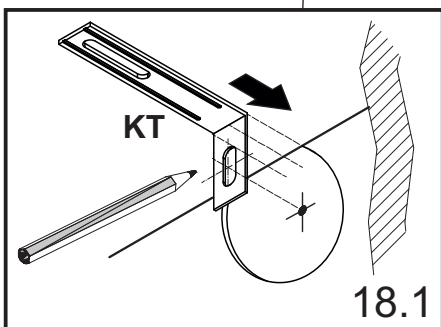
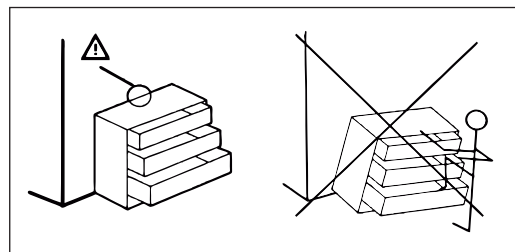
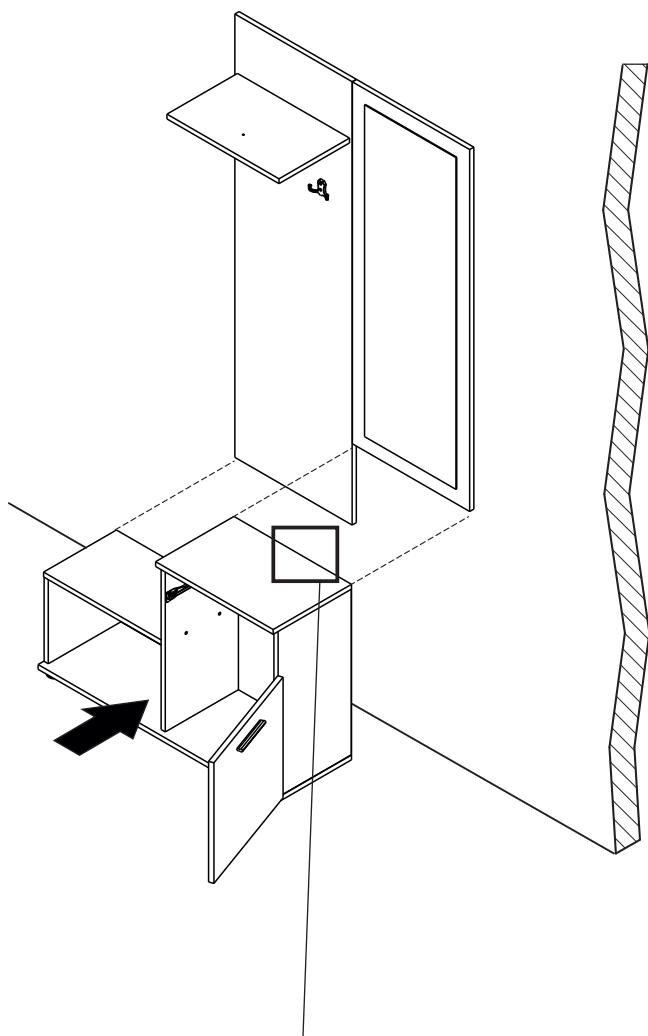
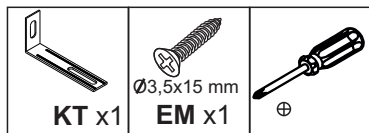

18.1

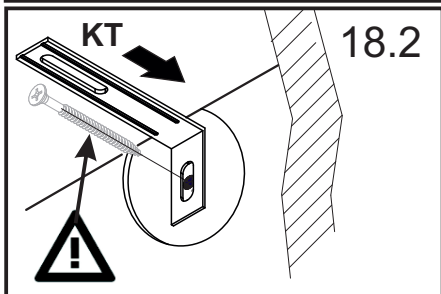

18.2

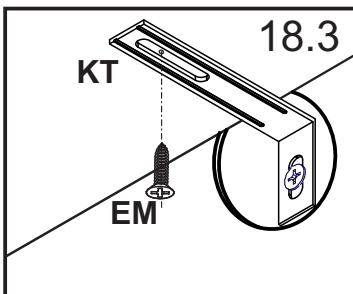

18.3



DEUTSCH

Um ein Umkippen des Möbelstücks zu verhindern, muss es fix an der Wand befestigt werden. Überprüfen Sie die Art und Stärke der Wand. Passen Sie die passenden Schrauben und Dübel für die Wände. Die Installation muss von einer sachkundigen Person durchgeführt werden.

ITALIANO

Per evitare che si rovesci sopra i mobili in modo permanente attaccarlo al muro. Controllare il tipo e la resistenza della parete. Regolare le viti e tasselli per le pareti. L'installazione deve essere effettuata da una persona competente.

FRANCAIS

Pour éviter le basculement des meubles, fixer au mur de façon permanente. Vérifiez le type et la solidité du mur. Choisir les vis et chevilles appropriées pour les murs. L'installation doit être effectuée par une personne compétente.

ENGLISH

To prevent the piece of furniture from falling over, please attach it permanently to the wall. Check the type and strength of the wall. Choose the appropriate screws and dowels for the walls. Installation must be performed by a competent person.

POLSKI

Aby zapobiec przewróceniu się mebla, należy na stałe przymocować go do ściany. Sprawdź rodzaj i wytrzymałość ściany. Dobierz odpowiednie wkręty i kołki do rodzaju ściany. Montaż musi zostać wykonany przez osobę kompetentną.

ESPAÑOL

Para evitar que se vuelquen los muebles, fíjelos permanentemente a la pared. Compruebe el tipo y resistencia de la pared. Escoja los tornillos y tacos apropiados para la pared. La instalación debe ser realizada por una persona especializada.

ČESKÝ

Chcete-li zabránit převrácení nábytku, je potřebné ho trvalo připevnit ke stěně. Zkontrolujte typ a nosnost stěny. Vyberte si vhodné šrouby a hmoždinky pro stěny. Instalace musí být provedena kvalifikovanou osobou.

PORTUGUÊS

Para evitar tombamento móveis permanentemente anexá-lo a parede. Verifique o tipo e resistência da parede. Escolha de parafusos e buchas apropriadas para a parede. A instalação deve ser efectuada por uma pessoa competente.

SLOVENSKÝ

Ak chcete zabrániť prevráteniu nábytku, je potrebné ho trvalo pripnúť ku stene. Skontrolujte typ a nosnosť steny. Vyberte si vhodné skrutky a hmoždinky pre steny. Inštalácia musí byť vykonaná kvalifikovanou osobou.

HRVATSKI

Da biste spriječili prevrtanja namještaja trajno ga pričvrstite na zid. Provjerite tip i snagu zida. Podesite odgovarajuće šrafove i utikače za zidove. Instalacija mora biti izvedena od strane stručne osobe.

MAGYAR

A bútorok felborulásának megelőzése érdekében tartósan rögzítse a falhoz. Ellenőrizze a fal típusát és terhelhetőségét. Válassza ki a falhoz megfelelő csavarokat és tipliket. Az installációt szakképzett személynek kell elvégeznie.

SRPSKI

Da biste spriječili prevrtanja namještaja trajno pričvršćivanje na zid. Provjerite tip i snagu zida. Podeseite odgovarajuće šrafove i čepove za zidove. Instalacija mora biti izvedena od strane nadležnog lića.