

D- Montageanleitung GB- Assembly instructions F- Instructions de montage PL- Instrukcja montażu
RU- Инструкция по монтажу NL- Montagehandleiding TR- Montaj talimatı RO- Instrucțiuni de montaj
IT- Istruzioni per il montaggio SK- Njvod na montáž CZ- Njvod k montáži HU- Szerelési útmutató

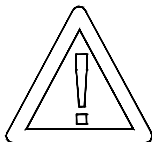

- D** Allgemeiner Sicherheitshinweis:
Nicht mehr benötigte Verpackungsmaterialien und Kleinteile von Kindern fernhalten!
- GB** General safety instructions:
Package material you do not need any more take far away from children.
- F** Consigne de sécurité:
Ecarter les matériaux d'emballage et petites pièces inutiles de la portée des enfants.
- PL** Ogólne zasady bezpieczeństwa:
Nie potrzebne opakowania i małe części chronić przed dziećmi!
- RU** Общие указания по безопасности:
Неиспользуемые упаковочные материалы и мелкие детали следует хранить в недоступном для детей месте!
- NL** Algemene veiligheidsinstructie:
Verpakkingsmaterialen die u niet meer nodig heeft en kleine onderdelen uit de buurt van kinderen houden!
- TR** Genel güvenlik uyarısı:
Kullanılmayan ambalaj malzemeleri ve küçük parçaları çocuklardan uzak tutun!
- RO** Indicație generală de siguranță:
Ambalajele care nu mai sunt necesare și piesele de mici dimensiuni nu vor fi lăsate la îndemâna copiilor!
- IT** Indicazioni generali per la sicurezza:
Tenere lontano da bambini materiali di imballaggio non più necessari e minuterie!
- SK** Všeobecné bezpečnostné upozornenie:
Nepotrebný baliaci materiál a malé diely uchovávať mimo dosahu detí!
- CZ** Všeobecné bezpečnostní upozornění:
Obalové materiály a malé díly, které už nepotřebujete, udržujte mimo dosah dětí!
- HU** Általános biztonsági tudnivaló:
Ha már nincs szüksége a csomagolóanyagokra és apró darabokra, tegye őket olyan helyre, ahol nem férhetnek hozzá gyermekek!

Modell, model, modèle, Model, Модель,
Model, Model, Model, Modello, Model:

CORINNA LEB

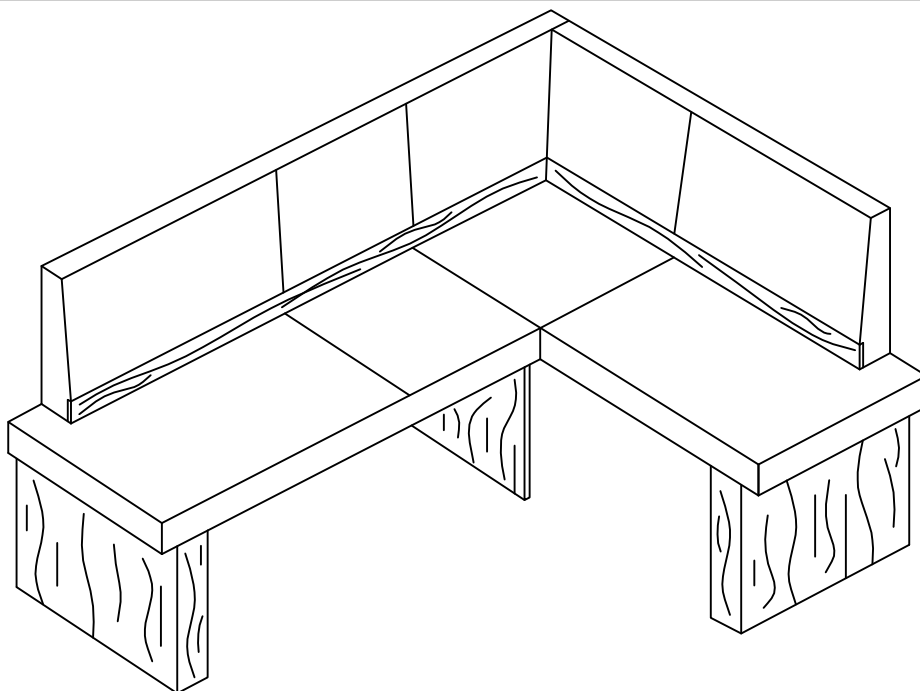

Montage mit, assembly by, Montage par,
Montować z, Сборка с помощью,
Montage met, Montaj aleti, Montaj cu,
Montaggio con, Montáž s, Montáž s,
Szerelés ezzel:

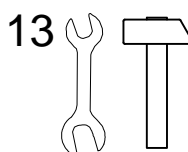
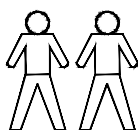

Werkzeug, tools, outils,
Narzędzia, Инструмент,
Gereedschap, Alet, Scule,
Utensile, Nářadí, Nářadí,
Szerszám:

Servicekarte / servicecard / carte de service / Karta gwarancyjna / Сервисная карточка / Servicekaart / Servis karti / Carte de service/ Scheda Servizio assistenza/ Servisná karta/ Servisní karta/ Szerviz kártya

Modell, model, modèle, Model, Модель, Model, Model, Model, Modello, Model:

CORINNA LEB

D Bitte füllen Sie die Servicekarte sorgfältig aus und markieren Sie bitte das betreffende Teil, damit Sie alle nötigen Daten bei Ihrer Ersatzteilbestellung zur Hand haben. Die Telefon-Service-Nummer finden Sie auf Ihrer Rechnung oder in unseren Werbemitteln.

GB Please fill out this servicecard accurate and specify the spare part number by marking. The Hotline-Number you find in Katalog or publicity.

F Merci de remplir la carte de service soigneusement et de codifier la pièce concernée afin de disposer des données nécessaires à la commande des pièces de rechange. Vous trouvez le numéro de téléphone de notre service commercial sur votre confirmation de commande ou sur la facture.

PL W celu dostarczenia wszystkich informacji dla zamówienia części zamiennych, prosimy rzetelnie wypełnić kartę gwarancyjną i wskazać na karcie uszkodzoną część. Telefon serwisu znajduje Państwo na rachunku lub na załączonej ulotce.

RU Пожалуйста, внимательно заполните Сервисную карточку и отметьте соответствующую деталь для того, чтобы иметь всю необходимую информацию при заказе запасных частей. Сервисный номер телефона указан на Вашем счёте или в наших рекламных материалах.

NL De servicekaart zorgvuldig invullen en het betreffende onderdeel markeren, opdat u bij de bestelling van het vervangende onderdeel de noodzakelijke gegevens bij de hand heeft. Het servicetelefoonnummer vindt u op uw factuur of in ons reclamemateriaal.

TR Yedek parça siparişiniz sırasında gerekli tüm bilgilere sahip olmanız için, lütfen servis kartınızı dikkatli bir şekilde doldurun ve ilgili parçayı işaretleyin. Telefon-servis numarasını faturanız üzerinde ya da reklamlarımızda bulabilirsiniz.

RO Vă rugăm să completați cu atenție cartea de service și să marcați piesa respectivă, astfel încât să aveți la îndemână toate informațiile în momentul comandării piesei de schimb. Numărul de telefon pentru asistență se găsește pe factura dumneavoastră sau în materialele publicitare.

IT Vogliate compilare con cura la scheda per il Servizio assistenza e di evidenziare la parte interessata, al fine di avere a portata di mano tutti i dati necessari per l'ordine di parti di ricambio. Il numero di telefono del Servizio assistenza è riportato sulla vostra fattura o sul nostro materiale pubblicitario.

SK Servisnú kartu vyplňte prosím starostlivo a označte príslušný diel, aby ste pri objednávke náhradného dielu mali všetky potrebné údaje. Servisné telefónne číslo nájdete na potvrdenke alebo na našich reklamných prostriedkoch.

CZ Vyplňte prosím pečlivě servisní kartu a označte příslušný díl, abyste měli připravené všechny potřebné údaje při své objednávce náhradních dílů. Telefonní číslo servisu najdete na své faktuře nebo v našich reklamních materiálech.

HU Kérjük, töltsé ki figyelmesen a szerviz kártyát, és jelölje be a megfelelő részt, hogy rendelkezésre álljanak a pótalkatrészek megrendeléséhez szükséges adatok. A szerviz telefonszáma a számlán, vagy reklámanyagainkban található.

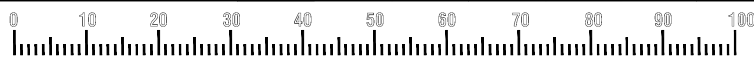
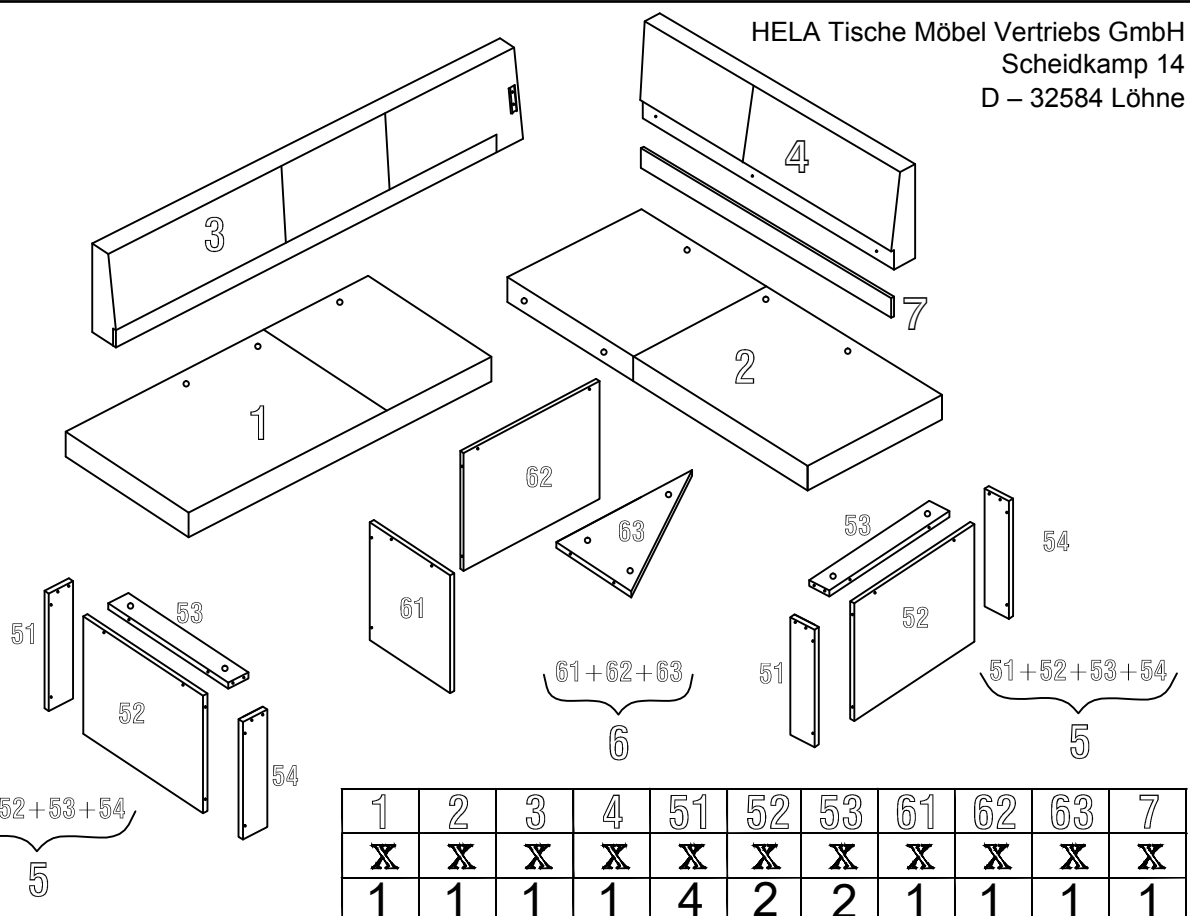

Artikel, Article, article, Wyrób, Товар, Artikel, Ürün, Articol, Articolo, Druh tovaru, Výrobek, Termékcikk	A	B	C	D	E	F	G	H	I	J
Menge, Quantità, quantità, Ilość, Количество, Hoeveelheid, Miktar, Cantitate, Quantità, MnožstvoMnožství, Mennyiség	26	7	21	8	12	17	2	1	5	1
Maße, Dimensions, dimensions, Wymiary, Размеры, Maten, Boyutlar, Dimensiune, Dimensiuni, Hmotnost/Rozměry, Mérete	Ø7 L-50	M8 L-30	Ø8 L-30	M8 L-80	Ø14 H4	Ø8	M8			
Abb., Picture, Croquis, Rysunek montażowy, Изображение, Afbeelding, Şekil, Figurá, Figura, Vyobrazenie, Obrázek, Ábra										

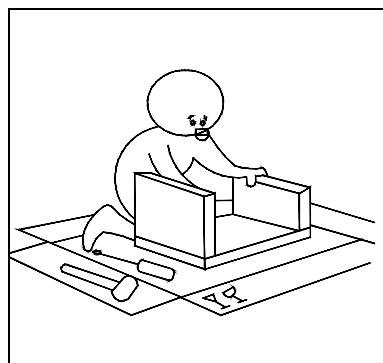
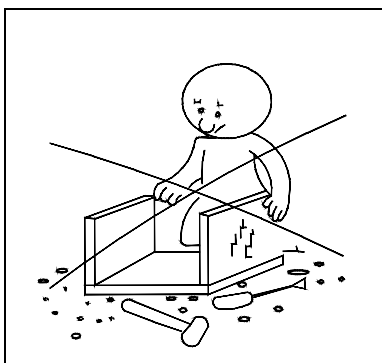
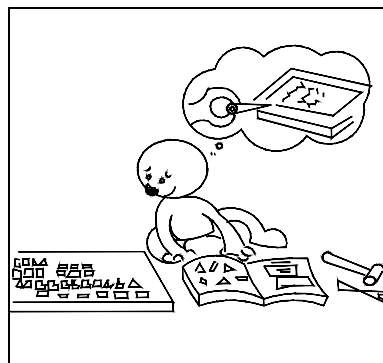
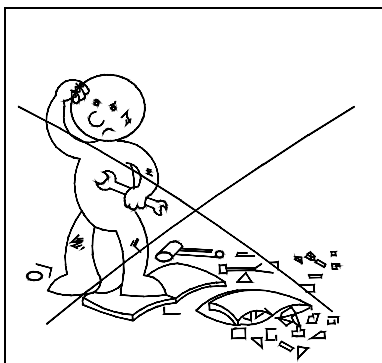
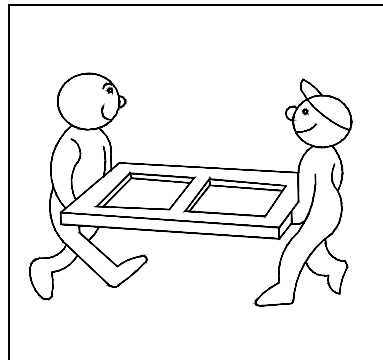
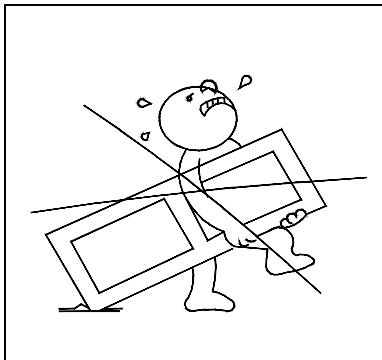
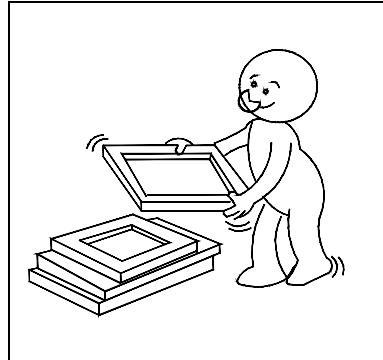
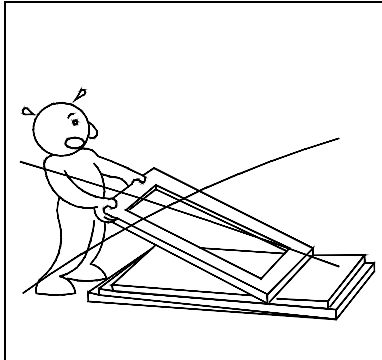
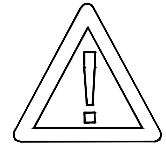
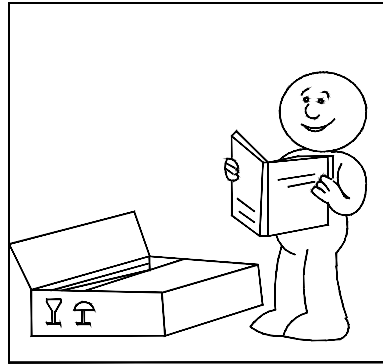
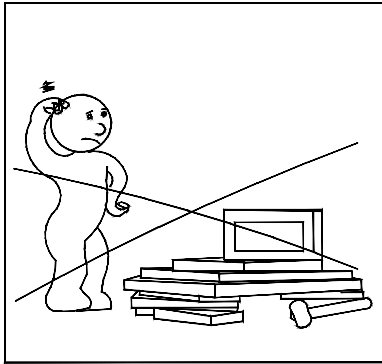

1

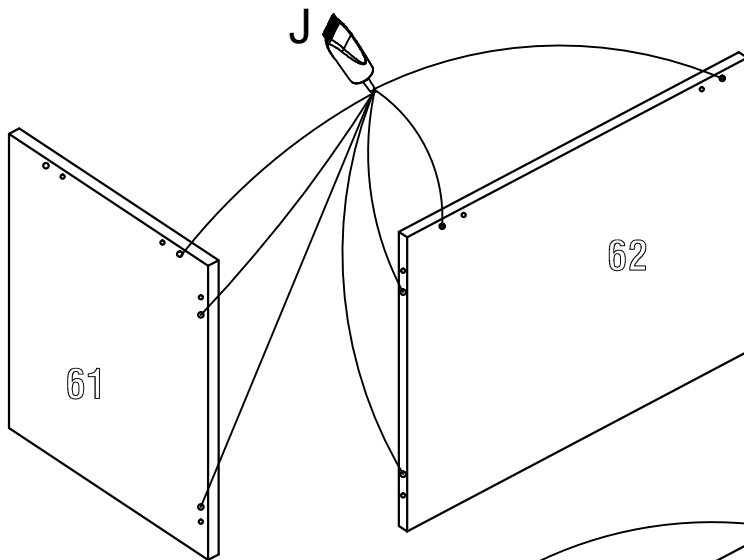

J

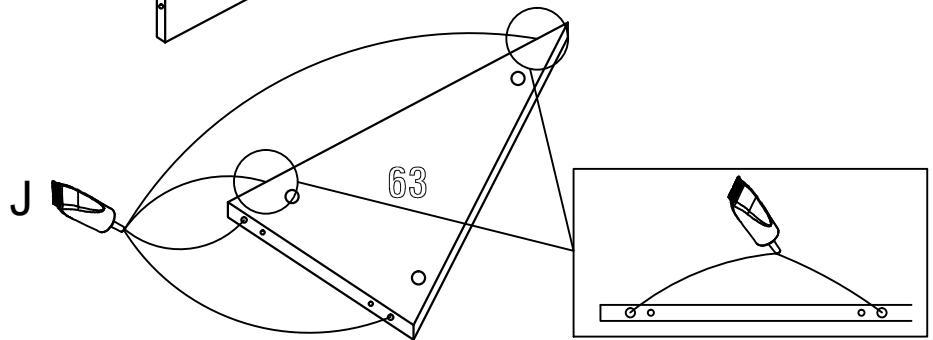

2

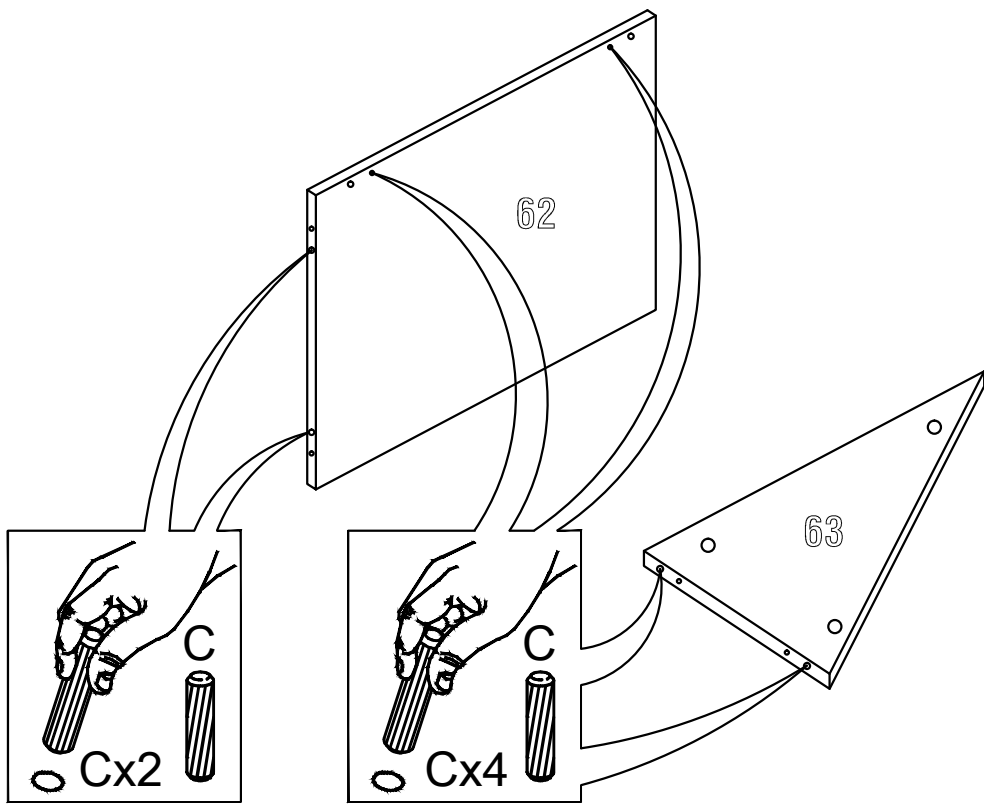

Cx2



Cx4





C



6

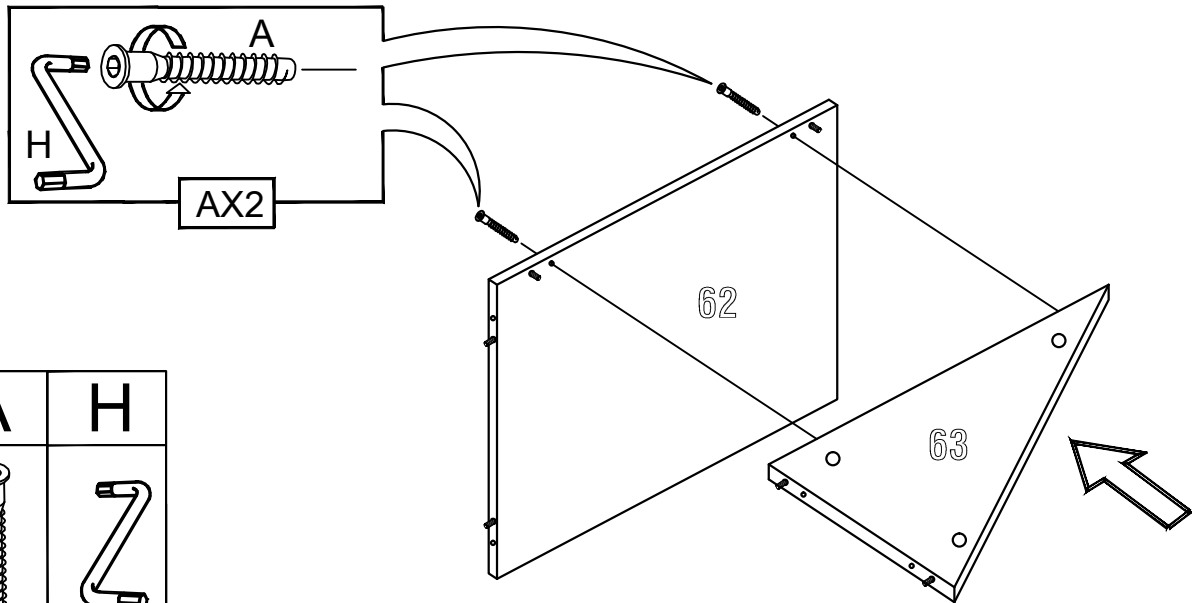

3

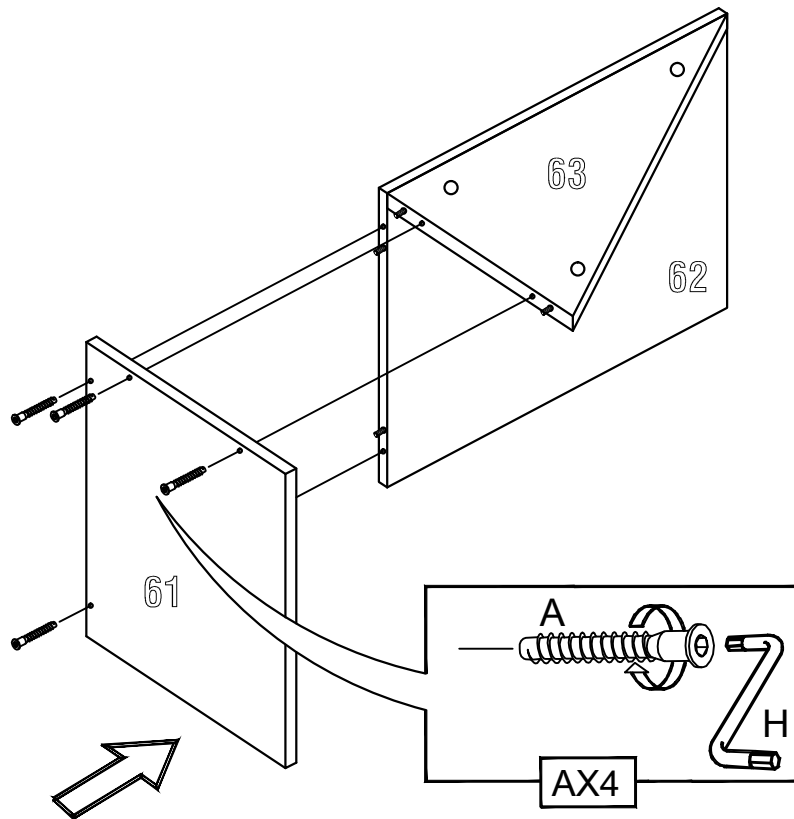

A	H
	
2	

4



A	H
	
4	

3

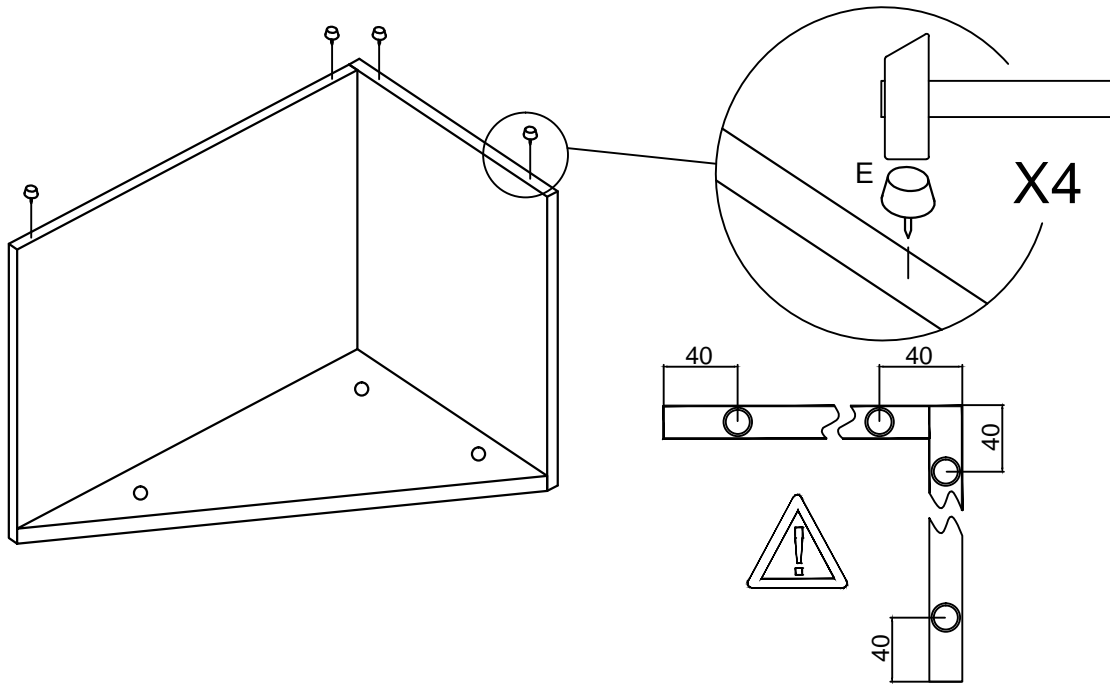

E



4

4

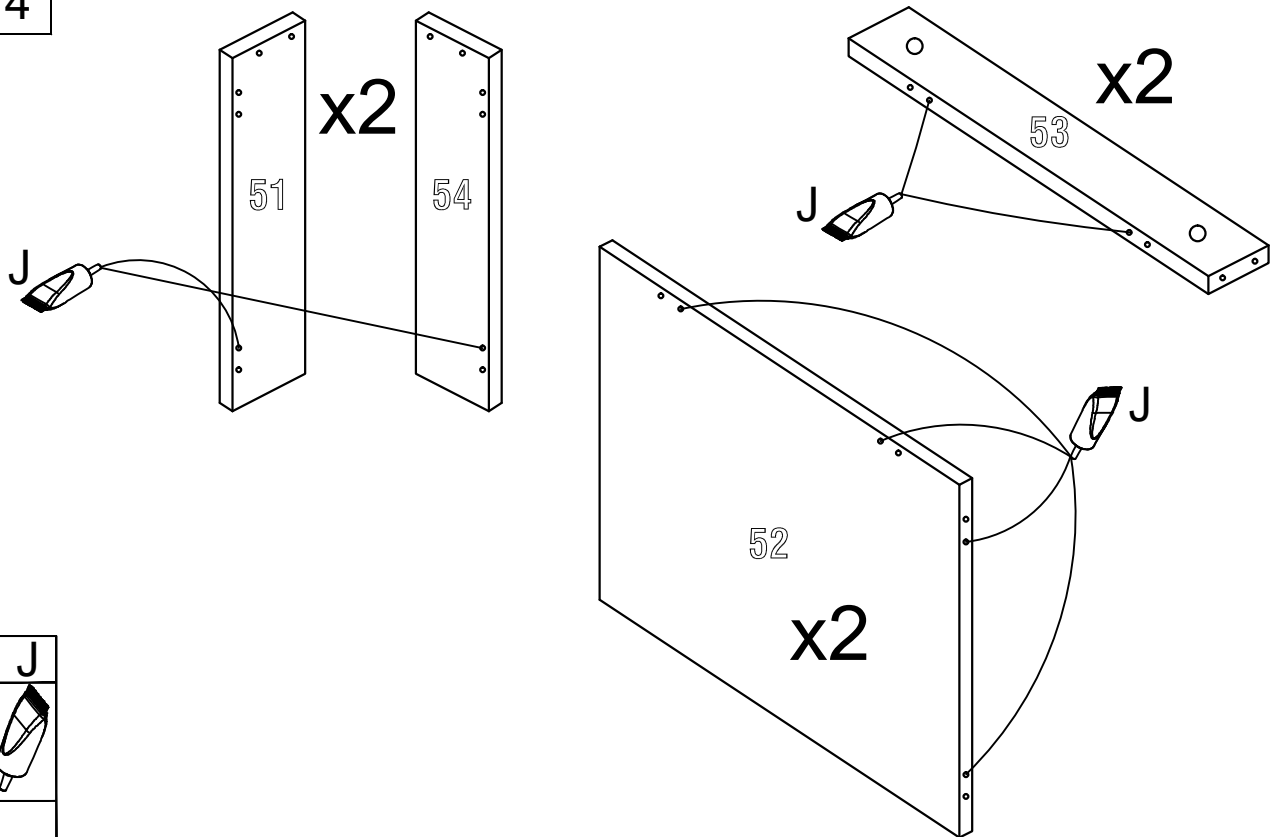

J



5

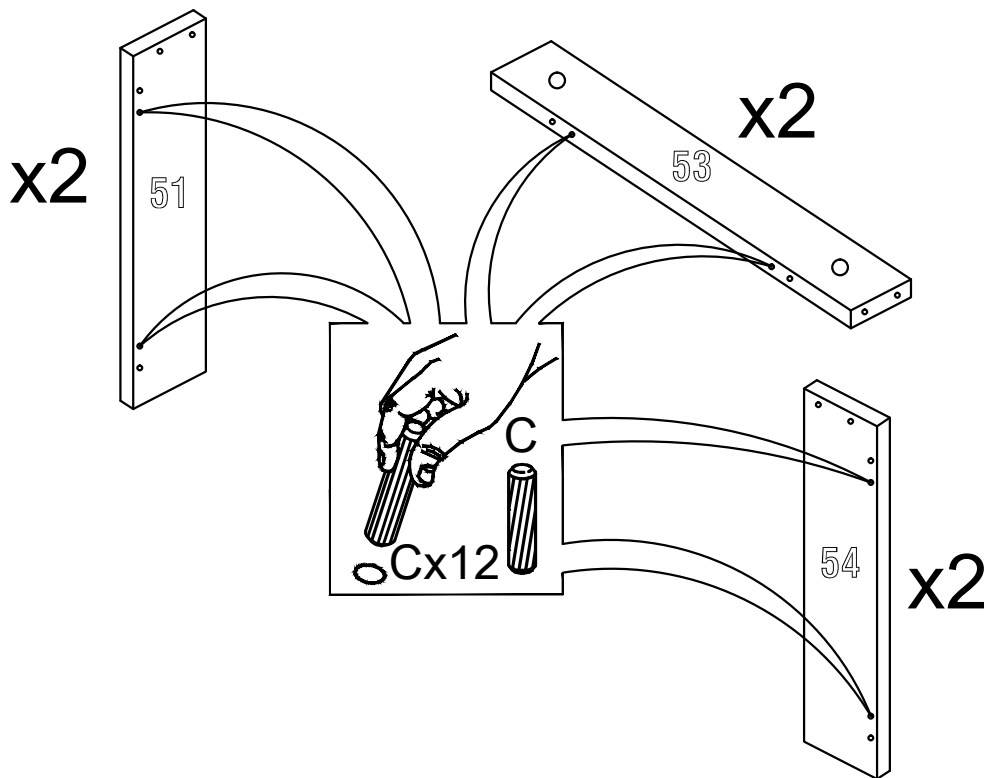

C

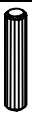

12

6

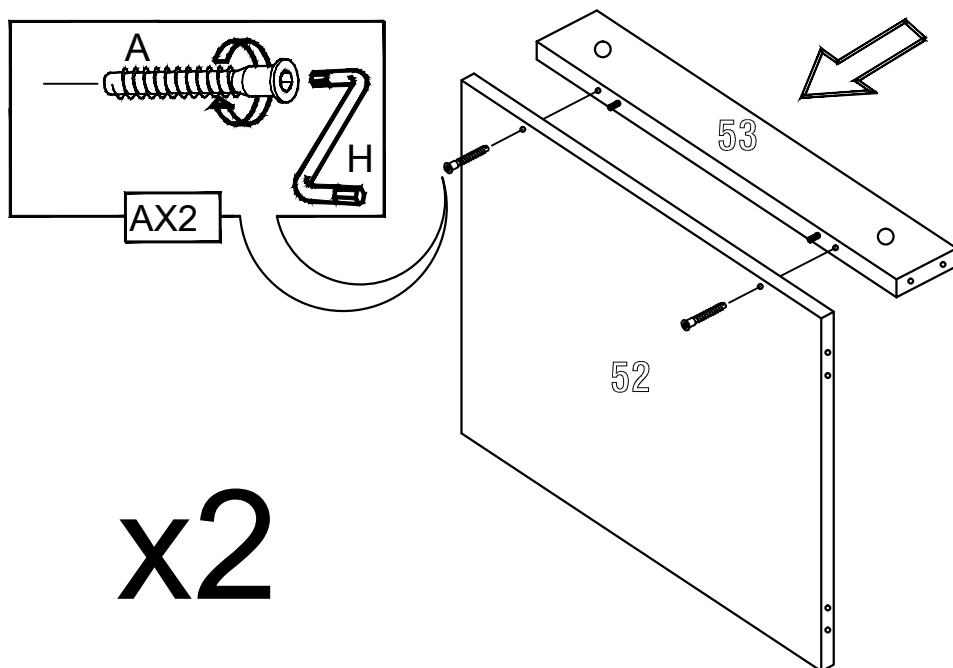

x2

A	H
4	

7

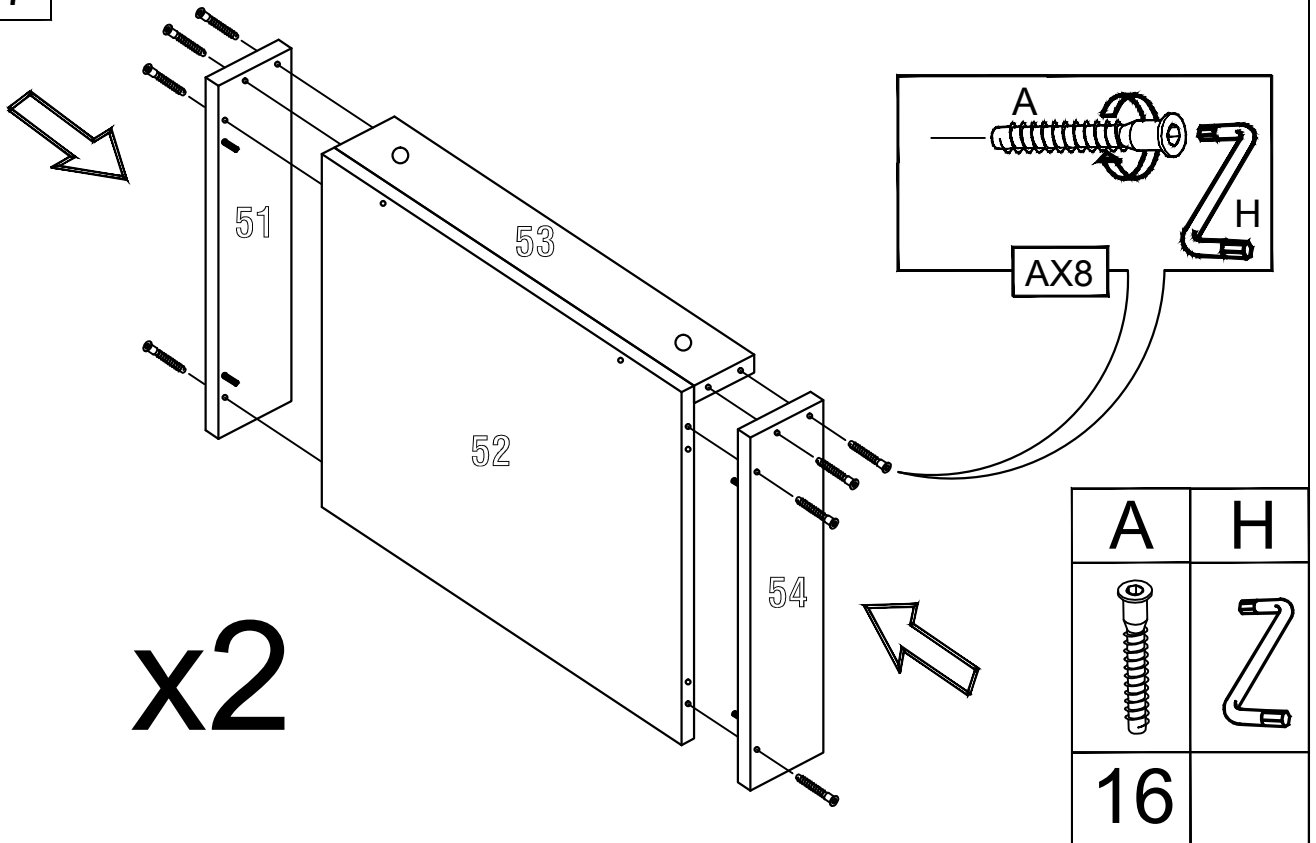

8

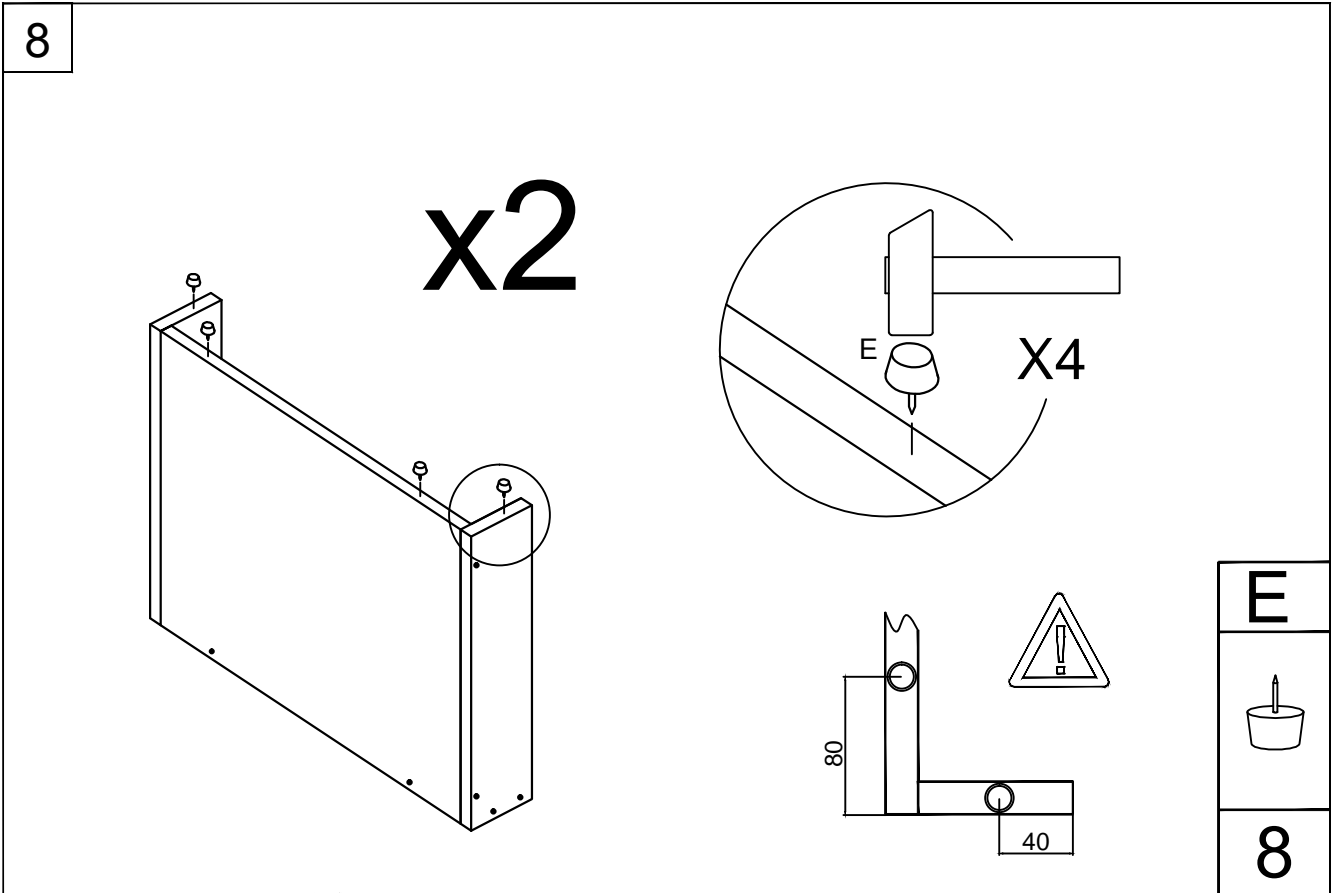

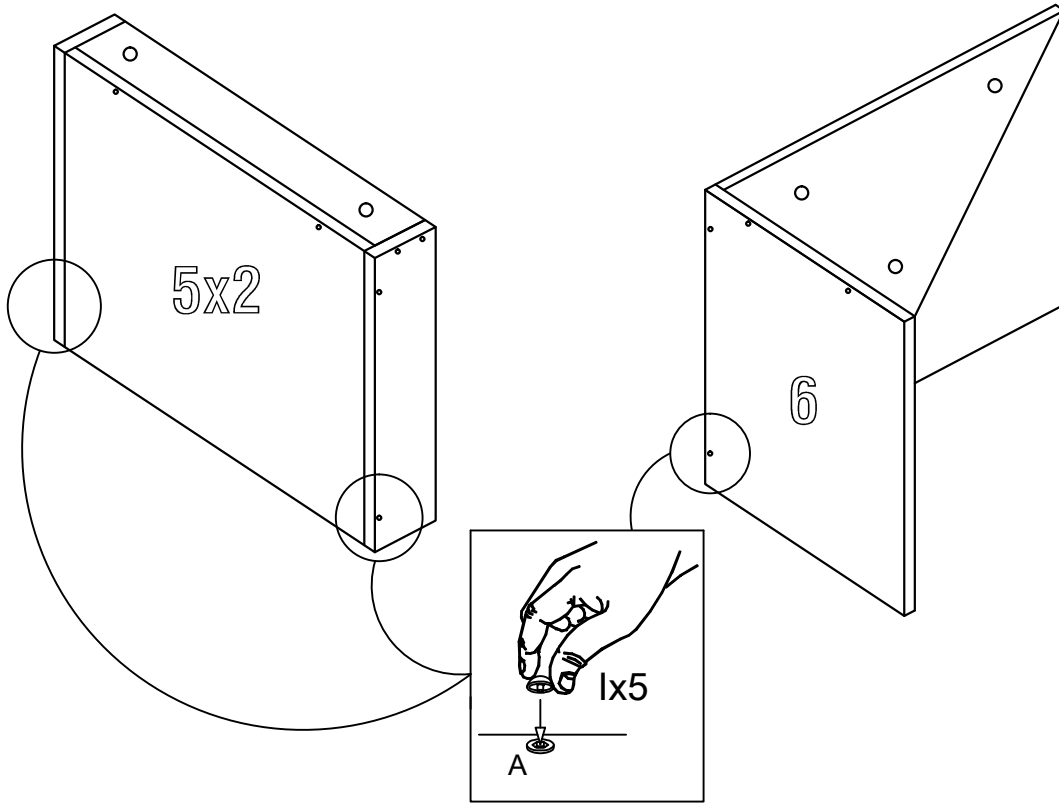

9

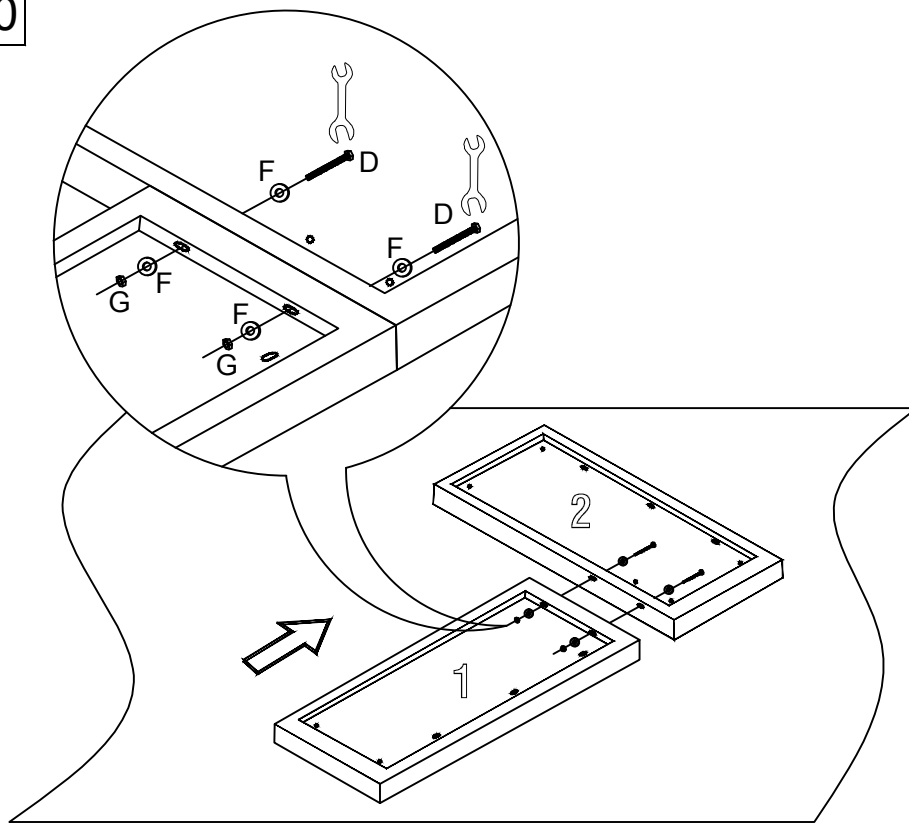

1

5

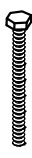

10

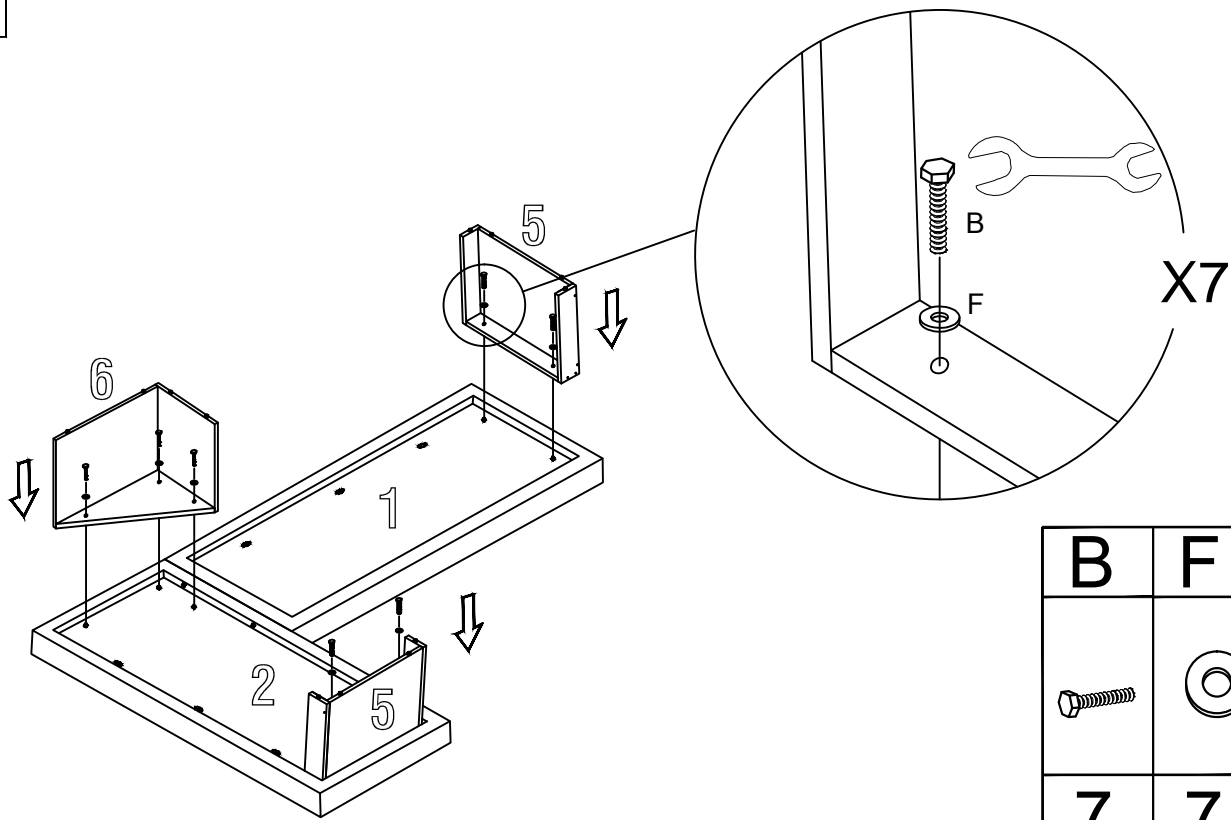

D	F	G
		
2	4	2

11



B	F
	
7	7

12

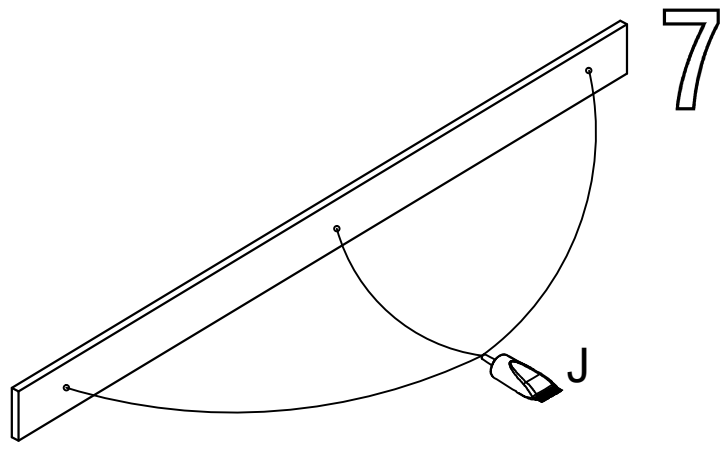

J

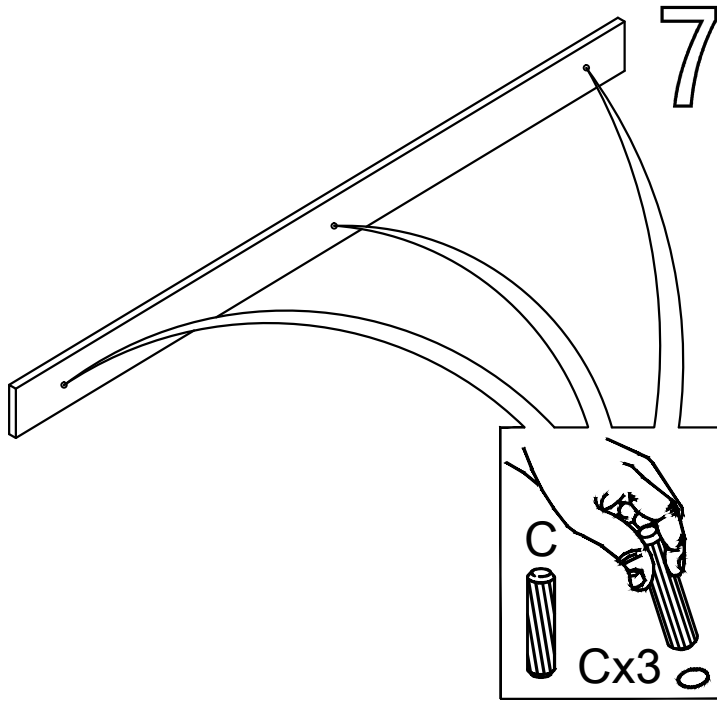

13

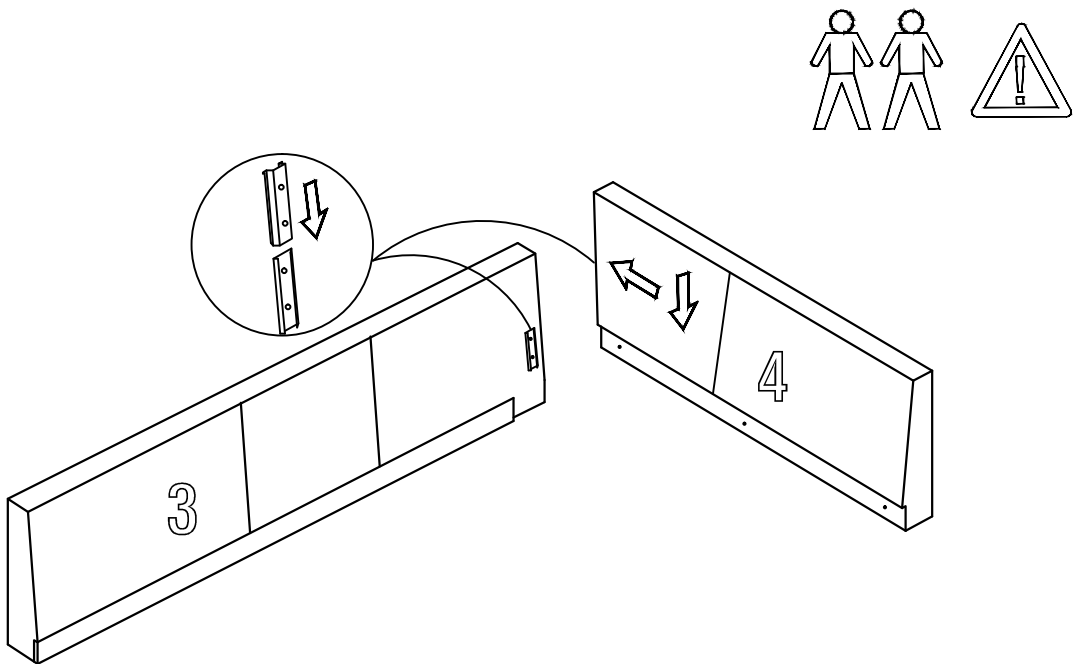

14

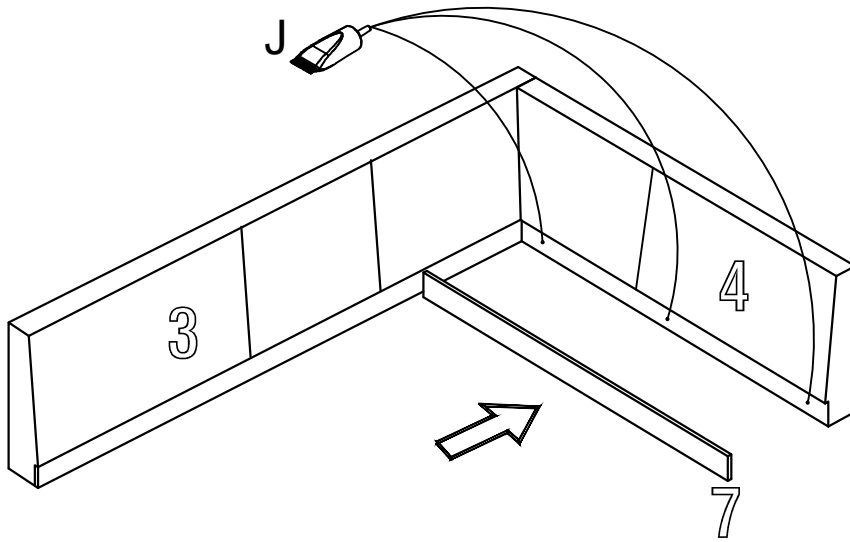
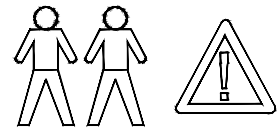

15



16

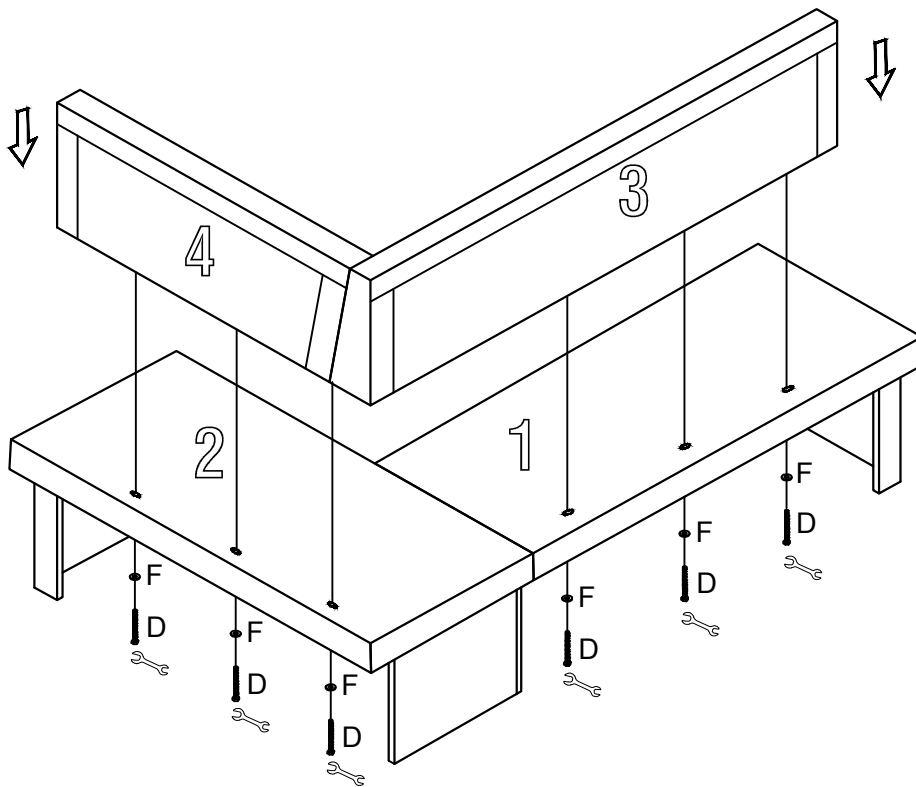
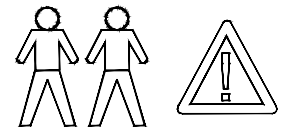

D	F
6	6

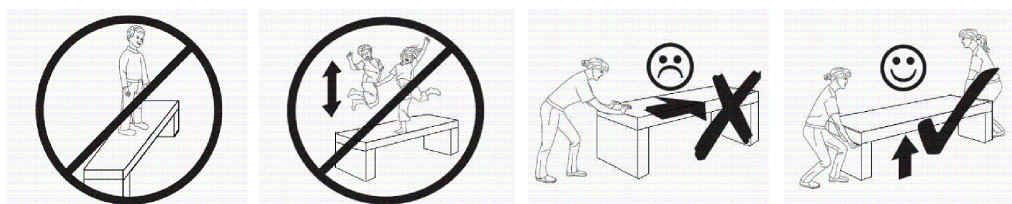
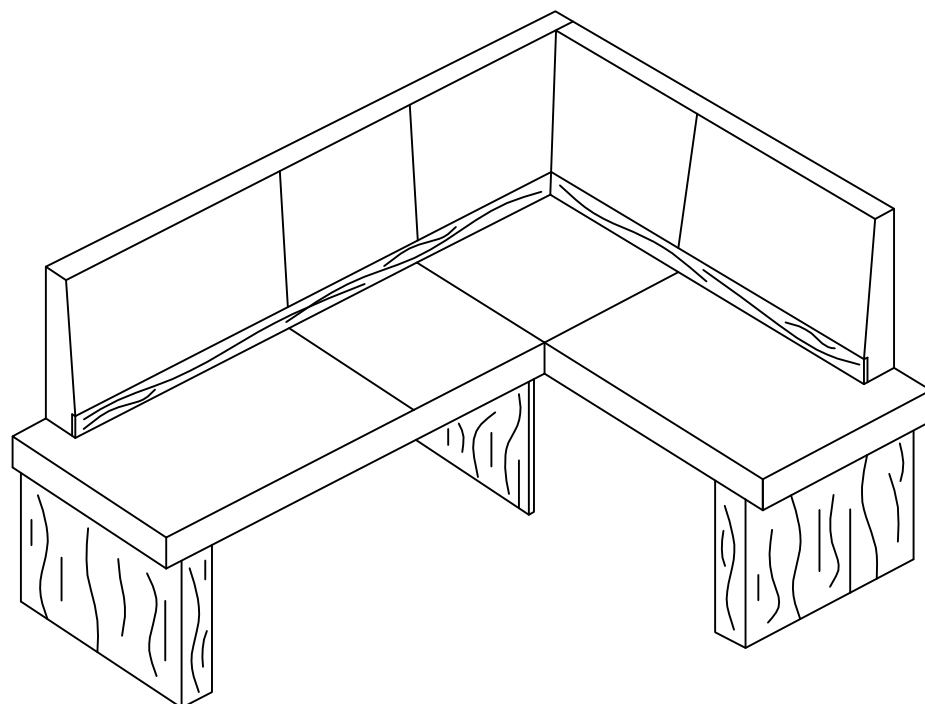

D	Ziehen Sie alle Schrauben sowie tragende Verbindungsteile nach ca. 5 Wochen nach, um eine dauerhafte Standsicherheit zu gewährleisten.
GB	After approx. 5 weeks, tighten all screws and load-bearing connecting parts to ensure permanent stability.
FR	Resserrez toutes les vis ainsi que les pièces de fixation au bout d'environ 5 semaines pour garantir une sécurité de fixation durable.
IT	Ristringere tutte le viti e giunture dopo ca. 5 settimane, al fine di garantire una durevole solidità.
NL	Draai alle schroeven en ook dragende verbindingstukken na ca. 5 weken nog eens vast, zodat een continue stabiliteit wordt gegarandeerd.
PL	Prosimy po ok. 5 tygodniach dokręcić wszystkie śruby w elementach łączeniowych. Zagwarantuje to Państwu trwałość i stabilność połączeń.
CZ	Dotáhněte všechny šrouby a nosné spojovací díly přibližně po 5 týdnech, aby se zaručila trvalá stabilita.
SK	Po cca 4 týždňoch dotiahnite skrutky, aby bola zaručená ich trvalá stabilita.
HU	Húzza utána – kb. 5 hét múlva – az összes csavart és a teherhordó összekötő-alkatrészeket a biztonság érdekében.
RO	Pentru a asigura o stabilitate de durată, strângeți după cca. 5 săptămâni toate șuruburile, precum și toate elementele portante de legătură.
TR	Tüm vida ve taşıyıcı bağlantı parçalarını kalıcı bir duruş güvenliğini sağlamak için yaklaşık 5 hafta sonra tekrar sıkınız.
RU	Подкрутите все болты, а также несущие соединительные детали приibl. через 5 недель для обеспечения устойчивости в течение длительного времени.